















ITEM NO: I260-9133











Display Case

Thank you for purchasing this quality product. Be sure to check all packing material carefully for small parts that may come loose inside the carton during shipment.



TOOLS REQUIRED (NOT PROVIDED)
PHILLIPS SCREWDRIVER 

HARDWARE LIST:			
No.	Description	Sketch	Quantity
A	Bolt Ø1/4" x 3/4"		22 PCS
B	Bolt Ø1/4" x 1-1/4"		6 PCS
C	Lock Washer Ø1/4"		28 PCS
D	Flat Washer Ø1/4" x 5/8"		28 PCS
E	Allen Wrench 4mm		1 PC
F	Hex Nut Ø5/16" x 1/2"		4 PCS
G	Hex Wrench 12mm		1 PC
H	Lock Washer Ø5/16"		4 PCS
I	Flat Washer Ø5/16" x 5/8"		4 PCS
J	Shelf Bracket		12 PCS
K	Wood Screw #6 x 5/8"		12 PCS
L	Wood Screw #9 x 3/4"		7 PCS

COMPONENTS LIST:			
No.	Description	Sketch	Quantity
1	Crown with top panel		1 PC
2	Left Tube side		1 PC
3	Right Tube side		1 PC
4	Wood Shelf Frame		2 PCS
5	Glass		2 PCS
6	Middle Assembly		1 PC
7	Wood Shelf		1 PC
8	Bottom Base		1 PC
9	Back Top Tube		1 PC
10	Metal (Long)		1 PC
11	Metal (Short)		2 PCS

STEP 1: Remove the drawer from the middle assembly: Fully extend the drawer, then press the plastic tab down on the right and up on the left at the same time as shown below. While holding the tabs pressed down/up, pull the drawer out.

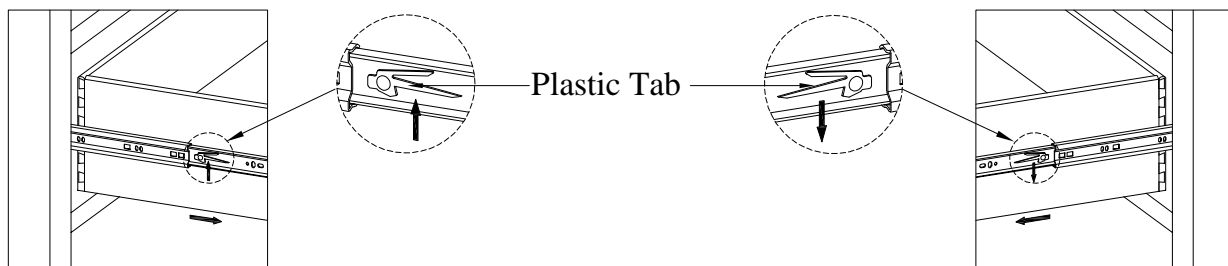

BEFORE USING THIS PRODUCT PLEASE READ, UNDERSTAND, AND FOLLOW THESE INSTRUCTIONS. Save these instructions for future reference.

FOR INDOOR USE ONLY



ITEM NO: I260-9133

Display Case

STEP 2: Pull out the top panel from the crown.

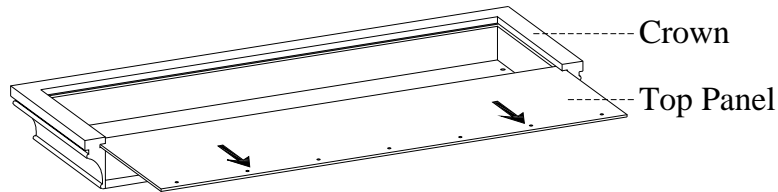

STEP 3: Insert the end on left/right tube side to back top tube, attach the left/right tube side to the middle assembly by using 6 bolts (B), lock washers(C) flat washers(D). Do not completely tighten bolts to allow some leeway for adjustment in STEP 4.

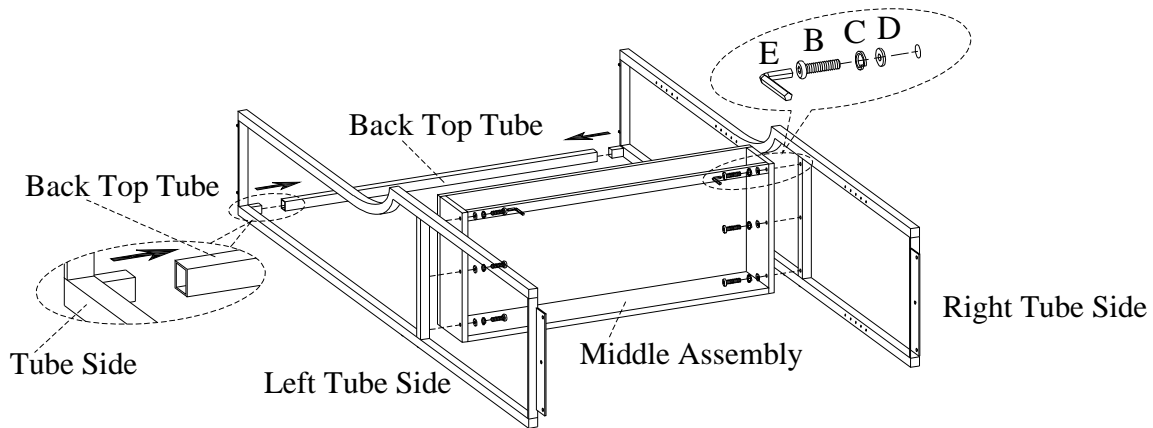

STEP 4-1: Align the lower metal panel on the left/right tube side with the groove in the bottom base by using 6 bolts(A), lock washers(C) and flat washers(D).

STEP 4-2: Align the bolts through holes in the crown by using 4 hex nuts (F), lock washers(H) and flat washers(I). Completely tighten all bolts and nuts used in Steps 3 & 4.

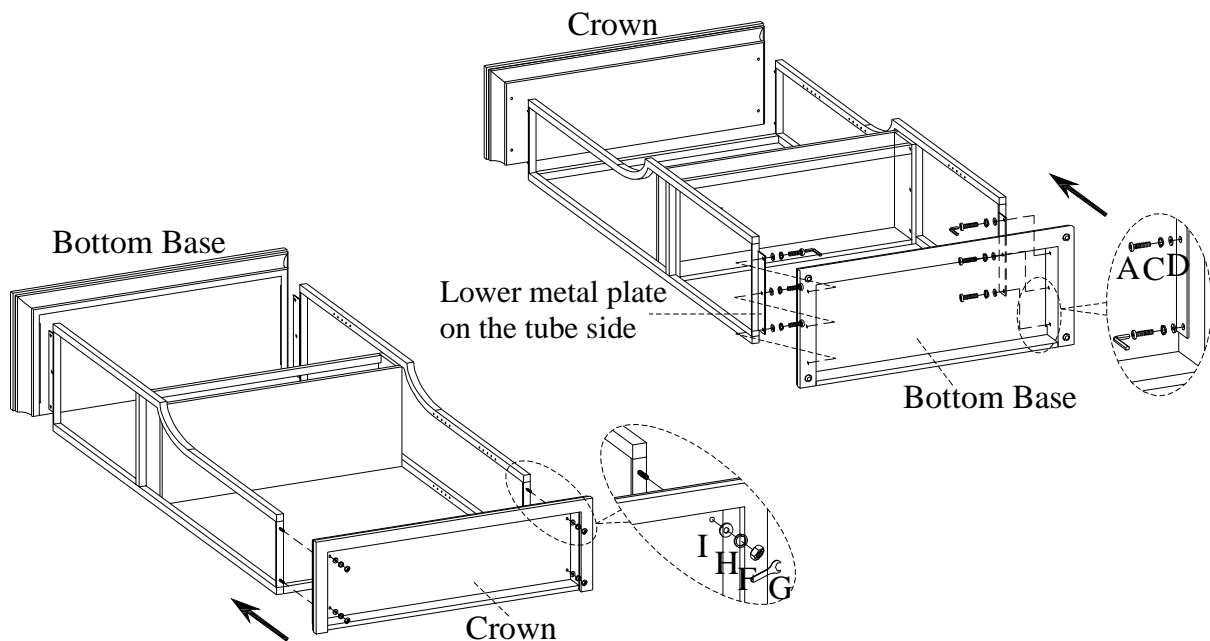

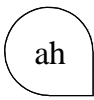

ITEM NO: I260-9133

Display Case

STEP 5-1: Align the top panel with the groove on the crown, then insert the top panel into the original position and secure it using 7 wood screws(L).

STEP 5-2: Attach the metal(long), the metals(short) and the back top tube to the case by using 16 bolts (A), lock washers(C) flat washers(D).

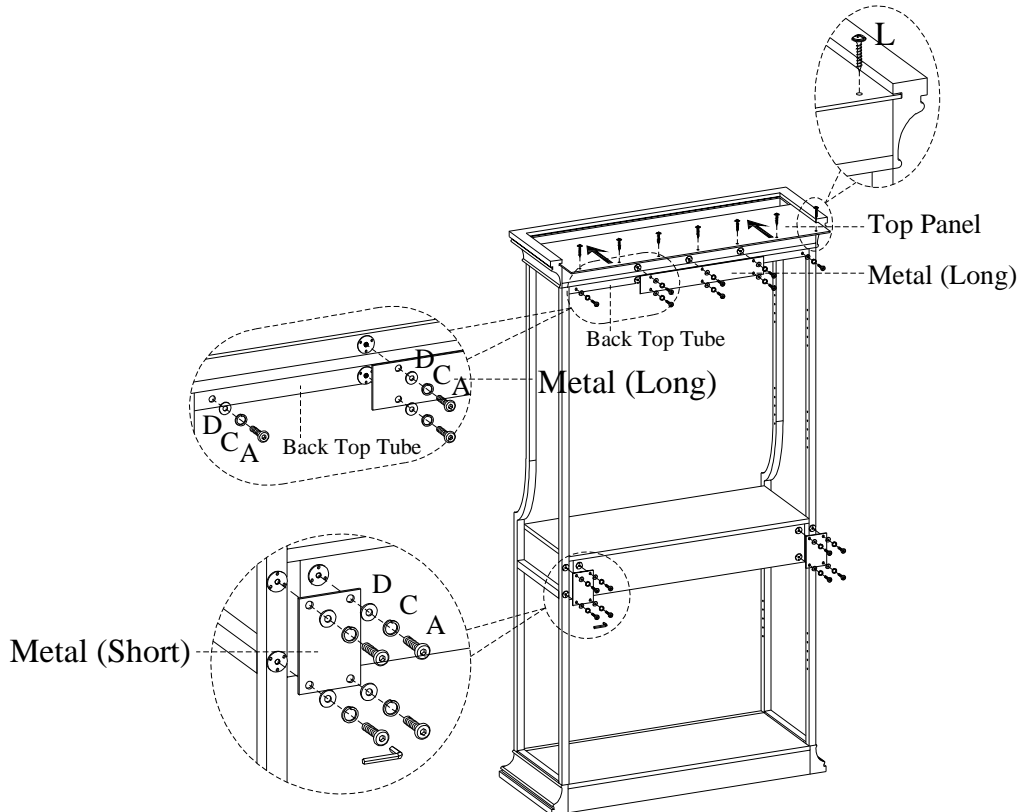

STEP 6: Replace the drawers in case: Fully extend the slides from the case. Then align the slides on the drawer to the slides on the case as shown. Push the drawer back in. You may have to slide the drawer in and out several times in order to properly align the ball bearings.

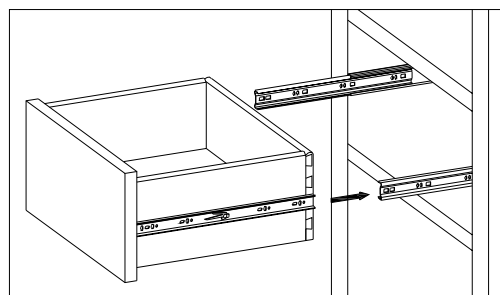



ITEM NO: I260-9133

Display Case

STEP 7: Insert the shelf bracket (J) into the holes on each tube side, then place the wood shelf frame and wood shelf on the shelf bracket, secure the wood shelf frame and wood shelf to shelf bracket with screws (K). Then place the glass on the wood shelf frame.

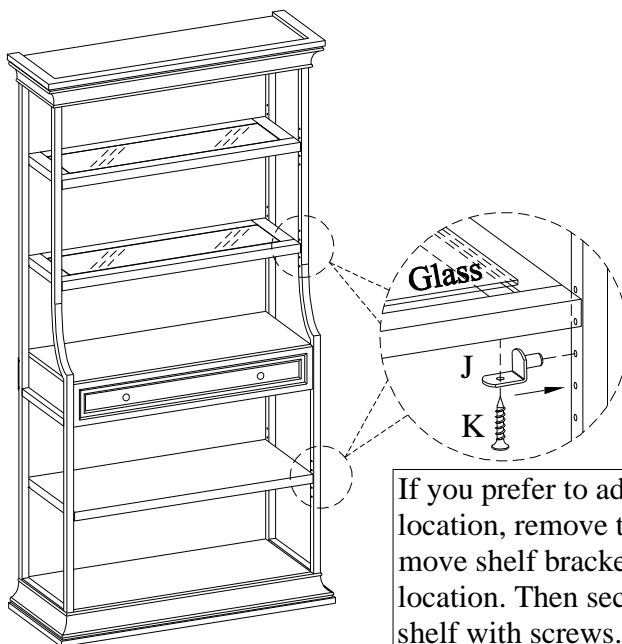

If you prefer to adjust the shelf location, remove the screws and move shelf brackets to the desired location. Then secure the brackets to shelf with screws.

FUNCTIONALITY INSTRUCTION

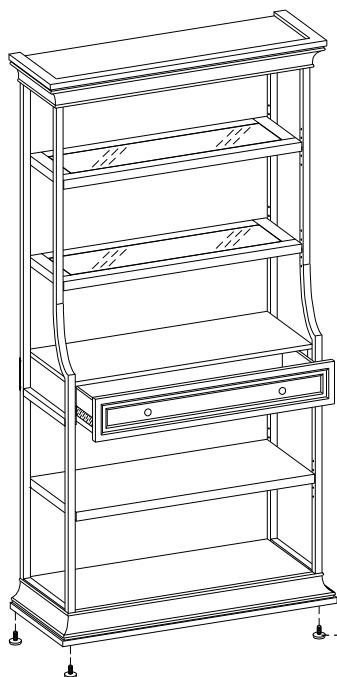

--- Leveler on case
Adjust the leveler
when necessary