

SUMMIT[®]

GRILL CENTER



Assembly Instructions

Instrucciones De Armado

Instructions Pour L'assemblage

#56559



56559 US 02/28/11
LP/NG
ENGLISH

CONSIDERATIONS BEFORE ASSEMBLING THIS GRILL

CONSIDERACIONES ANTES DE ENSAMBLAR ESTA BARBACOA CONSIDERATIONS AVANT D'ASSEMBLER CE GRILL

Be sure to consider placement options before unpacking or beginning assembly.

Unpack main grilling unit near the area where Summit Grill Center will reside. Weber recommends installing on a level, solid surface such as concrete, brick, or wood. Do not install on dirt, gravel, or flagstone.

DO NOT MOVE SUMMIT GRILL CENTER AFTER FULLY ASSEMBLED.

Do not attempt to assemble Grill Center in a location where surface pitch is greater than 2 inches.

Asegúrese de considerar las opciones de ubicación del equipo antes de comenzar a desempacar o comenzar el ensamblaje.

Desempaque la unidad principal de la barbacoa cerca del área donde se colocará el Centro de Asado Summit. Weber recomienda que se instale sobre una superficie nivelada y sólida como concreto, ladrillo o madera. No debe instalarse sobre tierra, grava o losas de piedra.

NO MUEVA EL CENTRO DE ASADO SUMMIT UNA VEZ ESTÉ COMPLETAMENTE ENSAMBLADO.

No intente ensamblar el Centro de Asado en una ubicación donde el espaciamiento de la superficie sea mayor de 2 pulgadas (5 cm).

Assurez-vous de réfléchir aux possibilités d'emplacement avant de déballer l'appareil ou de commencer l'assemblage.

Déballiez l'appareil principal pour la grillade à proximité de la zone où le Grill Center Summit va se trouver. Weber recommande l'installation sur une surface plane et solide, telle que du béton, de la brique ou du bois. N'effectuez pas l'installation sur des impuretés, sur du gravier ou sur des dalles.

NE DEPLACEZ LE GRILL CENTER SUMMIT APRES L'AVOIR COMPLETEMENT ASSEMBLE.

Ne tentez pas d'assembler le Grill Center à un emplacement où l'enfoncement dans la surface du sol est supérieur à 2 pouces (2,54 cm).

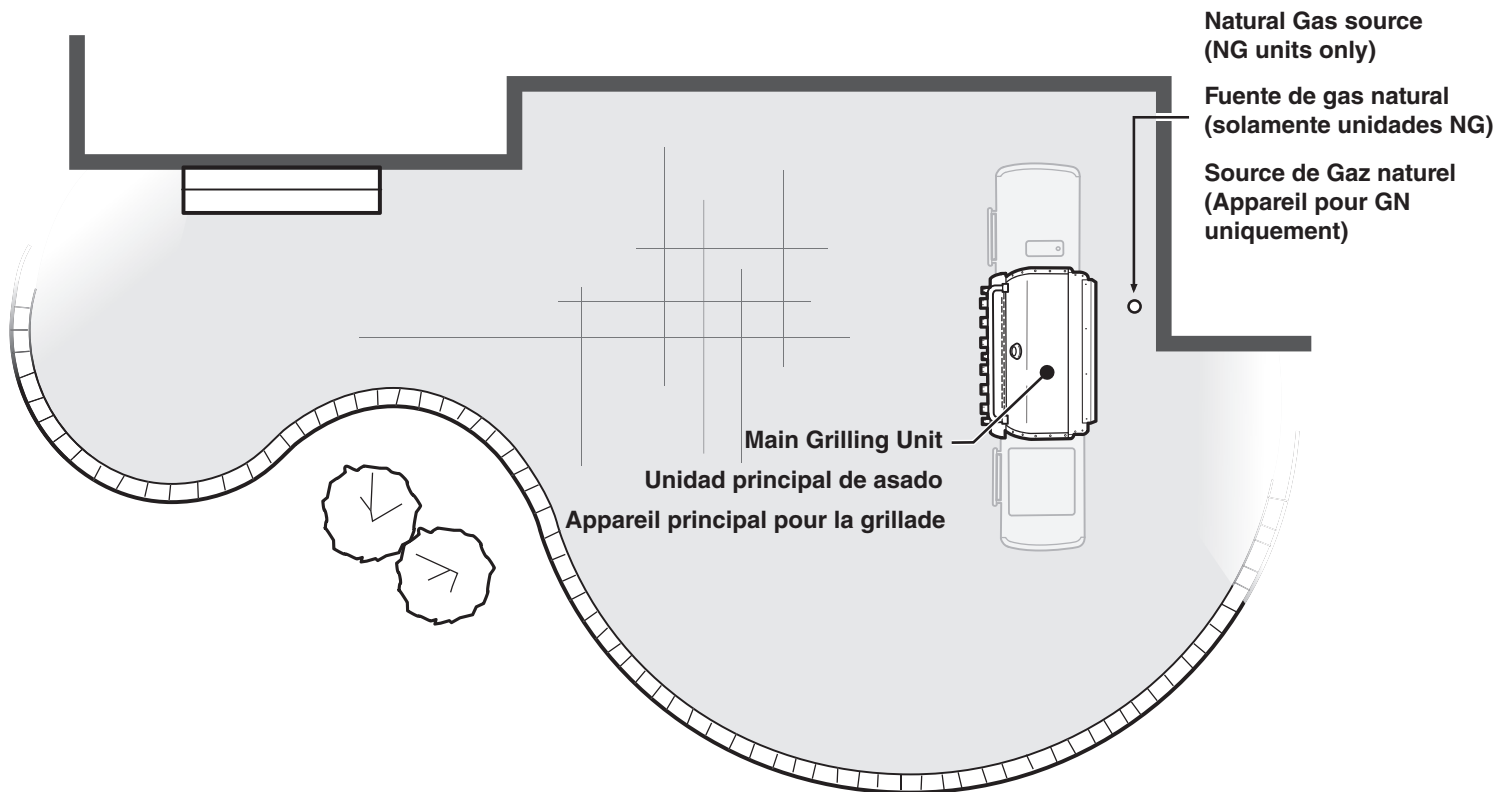

CONSIDERATIONS BEFORE ASSEMBLING THIS GRILL

CONSIDERACIONES ANTES DE ENSAMBLAR ESTA BARBACOA CONSIDERATIONS AVANT D'ASSEMBLER CE GRILL

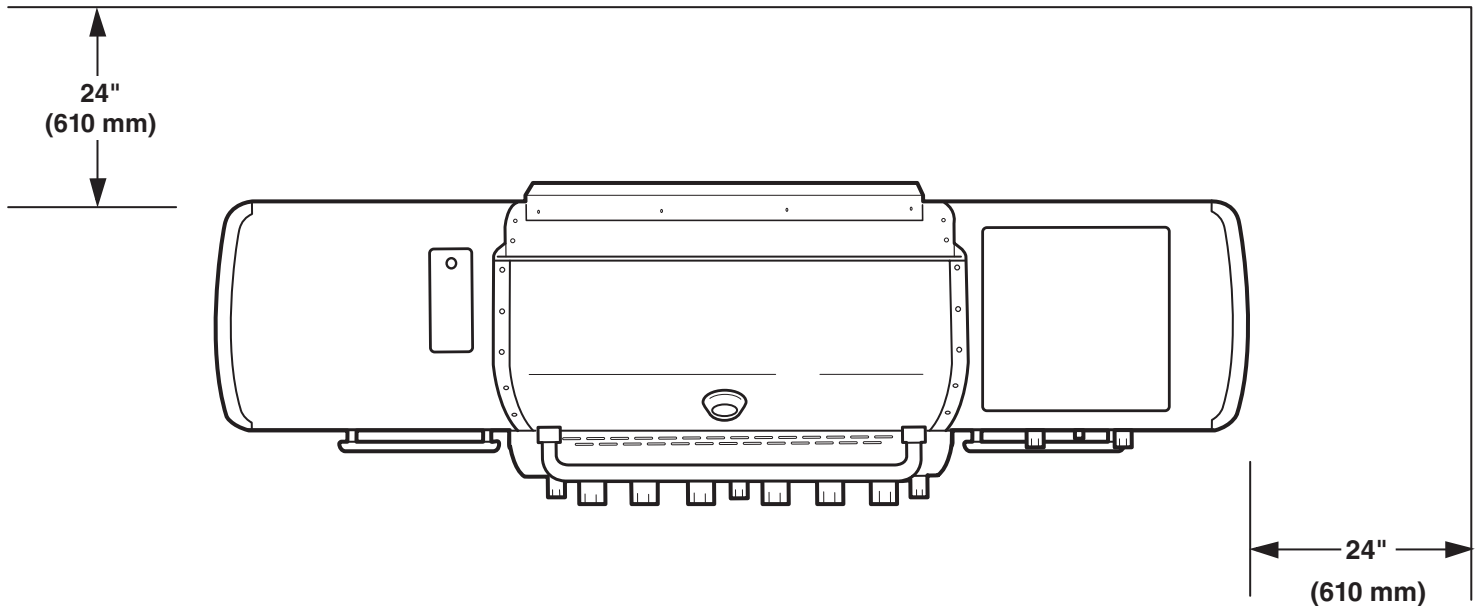

CLEARANCE FROM SURFACES OR STRUCTURES

⚠ WARNING: Clearance from any adjacent surface or structure is 24" (610 mm) from the back and sides of the grill.

NOTE: If you have questions on what materials are considered noncombustible, contact your local building materials supplier or fire department.

SEPARACIÓN DE LAS SUPERFICIES O ESTRUCTURAS

⚠ ADVERTENCIA: La separación de cualquier superficie o estructura adyacente es de 24 pulg. (610 mm) de los lados posterior y laterales de la barbacoa."

NOTA: Si tuviese cualquier pregunta sobre que materiales son considerados no combustibles, póngase en contacto con su proveedor local de materiales de construcción o con el cuerpo de bomberos.

ESPACE DEGAGE PAR RAPPORT AUX SURFACES OU AUX STRUCTURES

⚠ MISE EN GARDE : L'espace dégagé par rapport à toute surface ou structure adjacente est de 24" (610 mm) par rapport à l'arrière et aux côtés du grill.

REMARQUE : Si vous avez des questions sur les matériaux qui sont considérés comme non inflammables, veuillez contacter le fournisseur de matériaux de construction le plus proche ou les pompiers.

TOOLS NEEDED

HERRAMIENTAS REQUERIDAS • OUTILS NECESSAIRES

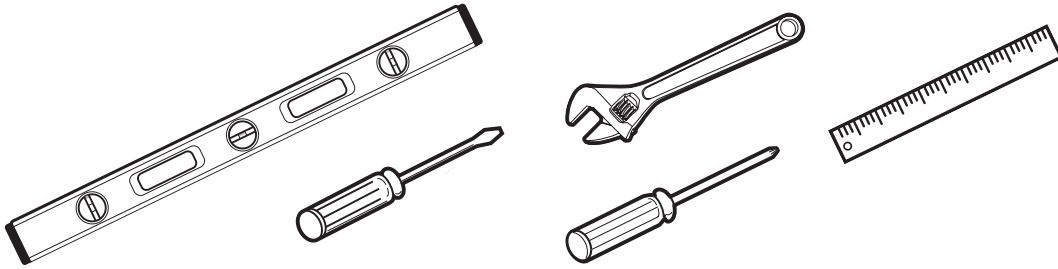

HARDWARE LIST

LISTA DE HERRAJES • LISTE DE LA QUINCAILLERIE

△ If any parts or hardware are damaged or missing, Contact the Customer Service Representative in your area using the contact information on our website. Log onto www.weber.com®.

△ Si cualquier herraje o pieza estuviese dañado o faltante, póngase en contacto con el Representante de Atención al Cliente en su área utilizando la información de contacto en nuestro sitio web. Conéctese a www.weber.com®.

△ Si de la quincaillerie ou des pièces sont détériorées ou manquantes, veuillez contacter le représentant du Service clientèle le plus proche à l'aide des coordonnées à votre disposition sur notre site Internet. Connectez-vous sur www.weber.com®.

Screw - 20
(1/4 - 20 x 1/2 In.)

Tornillo - 20
(1/4 - 20 x 1/2 pulg.)
Vis - 20
(1/4 - 20 x 1/2 po.)



Wire Shelf Frame Clip - 4

Grapa del bastidor del estante de alambre - 4
Pince pour le cadre de l'étagère métallique - 4

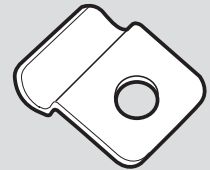

Hex Bolt - 4
(1/4 - 20 x 1/2 In.)

Perno hexagonal - 4
(1/4 - 20 x 1/2 pulg.)
Boulon hexagonal - 4
(1/4 - 20 x 1/2 po.)



Plastic Plug - 11

Tapón de plástico - 11
Fiche en plastique - 11



Screw - 11
(#10 - 16 x 3/4 In.)

Tornillo - 11
(#10 - 16 x 3/4 pulg.)
Vis - 11
(N°10 - 16 x 3/4 po.)



J-clip - 16

Grapa J - 16
Pince en J - 16

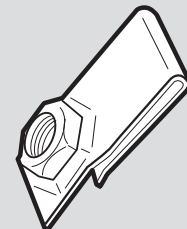

Washer - 24

Arandela - 24
Rondelle - 24



Wrench - 1

Llave - 1
Clé - 1

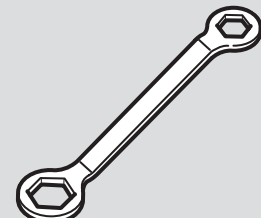

MAIN GRILLING UNIT PARTS LIST

LISTA DE PIEZAS DE LA UNIDAD PRINCIPAL DE ASADO LISTE DES PIÈCES DE L'UNITÉ PRINCIPALE POUR LA GRILLADE

Catch Pan Holder - 1

Soporte del plato recolector - 1
Support pour égouttoir - 1

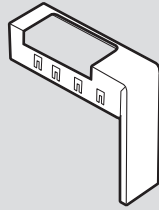

Catch Pan - 1

Plato recolector - 1
Egouttoir - 1

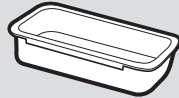

Disposable Drip Pan - 2

Bandeja de goteo desechable - 2
Egouttoir jetable - 2

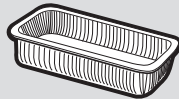

Cooking Grate - 3

Parrilla de cocción - 3
Grille de cuisson - 3

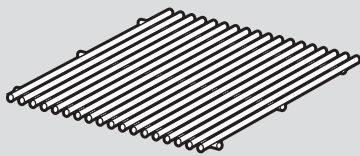

Warming Rack - 1

Rejilla para calentar - 1
Grille de maintien au chaud - 1

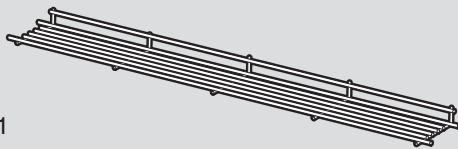

Battery Housing - 1

Compartimiento de la batería - 1
Logement des piles - 1

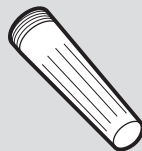

Rotisserie Fork - 4

Horquilla del asador rotativo - 4
Fourche de la rôtissoire - 4

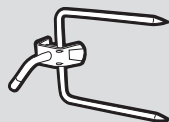

Rotisserie Spit - 1

Espetón del asador rotativo - 1
Broche de la rôtissoire - 1



Rotisserie Motor - 1

Motor del asador rotativo - 1
Moteur de la rôtissoire - 1

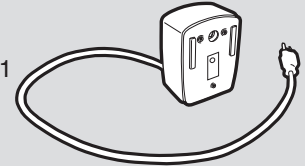

Slide-out Grease Tray - 1

Bandeja deslizante de grasa - 1
Plateau amovible pour la
récupération des graisses - 1

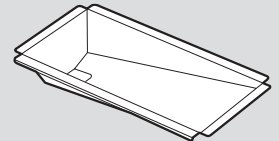

Flavorizer® Bar - 12

Barra Flavorizer® - 12
Barre Flavorizer® - 12

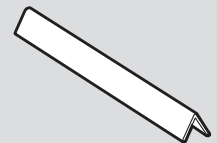

Smoker Bar - 1

Barra del ahumador - 1
Barre du fumoir - 1

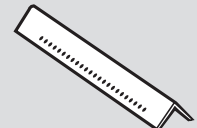

Smoker Box - 1

Caja del ahumador - 1
Boîtier du fumoir - 1

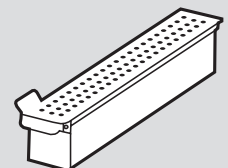

LEFT CABINET PARTS LIST

LISTA DE PIEZAS DEL GABINETE IZQUIERDO LISTE DES PIÈCES DU MEUBLE DE GAUCHE

Left Cabinet Side Table - 1

Mesa lateral del
gabinete izquierdo - 1

Meuble de gauche
Tablette latérale - 1

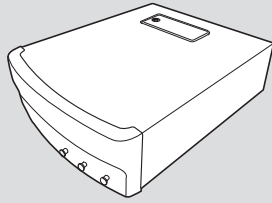

Paper Towel Holder - 1

Portatoallas de papel - 1
Support pour serviettes
en papier - 1

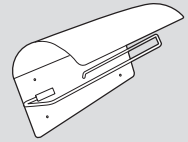

Left Cabinet Water Deflector - 1

Deflector de agua del
gabinete izquierdo - 1

Meuble de gauche
Déflecteur à eau - 1

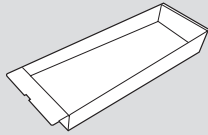

Left Side End Skirt - 1

Faldón extremo del lado izquierdo - 1
Jupe d'extrémité pour le
côté gauche - 1

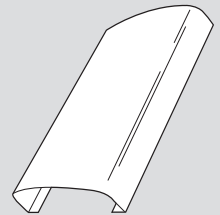

Left Cabinet Door - 1

Puerta del gabinete izquierdo - 1
Porte du meuble de gauche - 1

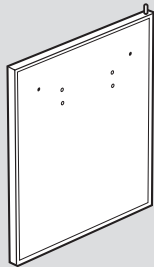

Left Frame - 1

Bastidor izquierdo - 1
Cadre de gauche - 1

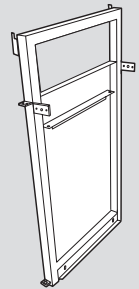

Left Door Handle - 1

Asa de la puerta izquierda - 1
Poignée de porte gauche - 1



Height-adjustable Leg - 2

Pata de altura ajustable - 2
Pied ajustable en hauteur - 2

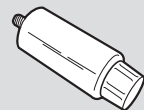

Left Cabinet Bottom Panel - 1

Panel inferior del
gabinete izquierdo - 1

Meuble de gauche
Panneau inférieur - 1

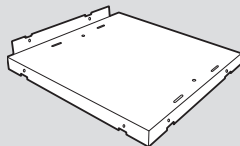

Wire Shelf Frame - 2

Bastidor del estante de alambre - 2
Cadre de l'étagère métallique - 2

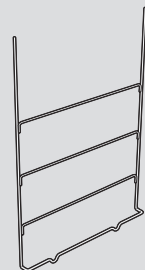

Left Cabinet Back Panel - 1

Panel posterior del
gabinete izquierdo - 1

Meuble de gauche
Panneau arrière - 1



Wire Shelf - 2

Estante de alambre - 2
Etagère métallique - 2

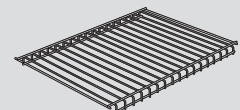

SIDE BURNER CABINET PARTS LIST

LISTA DE PIEZAS DEL GABINETE DEL QUEMADOR LATERAL

LISTE DES PIÈCES DU MEUBLE DU BRÛLEUR LATÉRAL

Side Burner Lid - 1

Tapa del quemador lateral - 1
Couvercle du brûleur latéral - 1

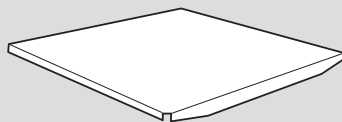

Wok Ring (see Owner's Guide) - 1

Aro del wok (ver Guía del Propietario) - 1
Bague pour wok (voir le Mode d'emploi) - 1



Side Burner Grate - 1

Parrilla del quemador lateral - 1
Grille du brûleur latéral - 1

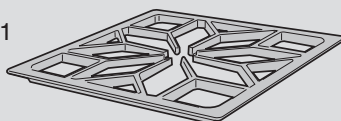

Side Burner inner Ring - 1

Aro interno del quemador lateral - 1
Bague interne du brûleur latéral - 1



Side Burner Outer Ring - 1

Aro externo del quemador lateral - 1
Bague externe du brûleur latéral - 1



Side Burner Head - 1

Cabezal del quemador lateral - 1
Tête du brûleur latéral - 1



Side Burner Assembly - 1

Ensamble del quemador lateral - 1
Assemblage du brûleur latéral - 1

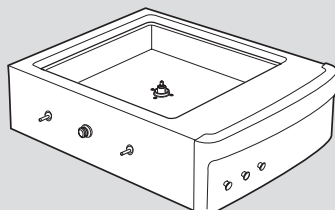

Sideburner Cabinet Water Deflector - 1

Deflector de agua del gabinete del quemador lateral - 1
Meuble du brûleur latéral
Déflecteur à eau - 1

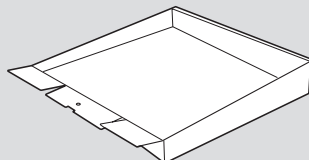

Side Burner Cabinet Door - 1

Puerta del gabinete del quemador lateral - 1
Brûleur latéral
Porte du meuble - 1

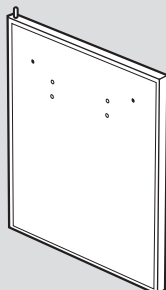

Right Door Handle - 1

Asa de la puerta derecha - 1
Poignée de porte droite - 1



Side Burner Cabinet Back Panel - 1

Panel posterior del gabinete del quemador lateral - 1
Meuble du brûleur latéral
Panneau arrière - 1



Side Burner Cabinet Bottom Panel - 1

Panel inferior del gabinete del quemador lateral - 1
Panneau inférieur du meuble du brûleur latéral - 1

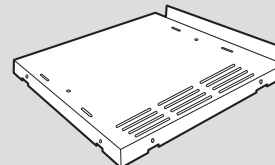

Right Frame - 1

Faldón extremo del lado derecho - 1
Jupe d'extrémité pour le côté droit - 1

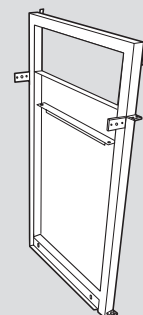

Right Side End Skirt - 1

Bastidor derecho - 1
Cadre droit - 1

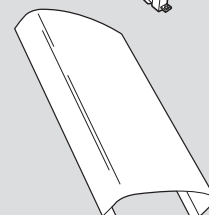

Side Burner Knob - 2

Perilla del quemador lateral - 2
Bouton du brûleur latéral - 2



Height-adjustable Leg - 2

Pata de altura ajustable - 2
Pied ajustable en hauteur - 2

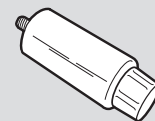

Wire Shelf Frame - 2

Bastidor del estante de alambre - 2
Cadre de l'étagère métallique - 2

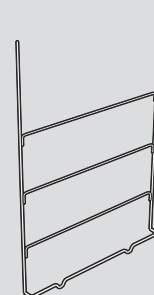

Left Cabinet Wire Shelf - 2

Estante de alambre - 2
Étagère métallique - 2

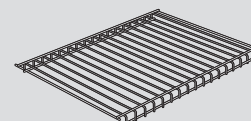

1

3-

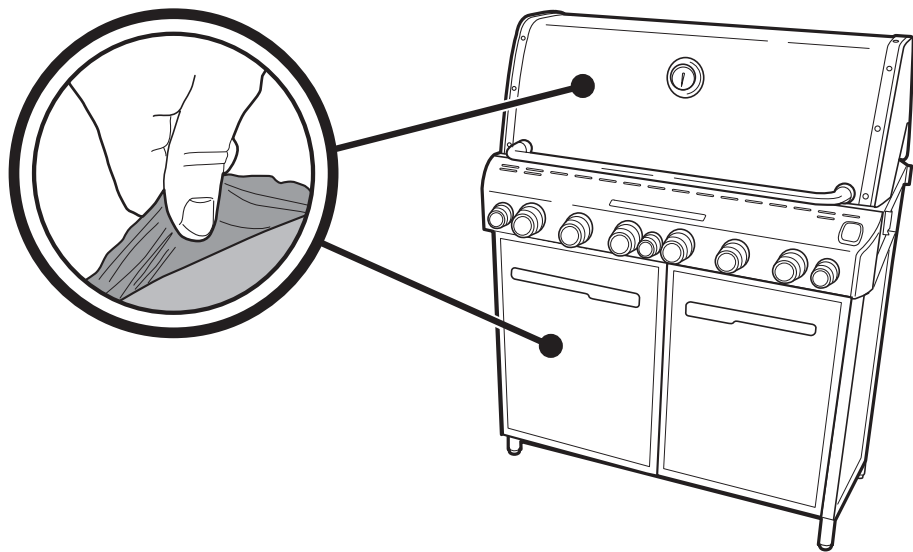
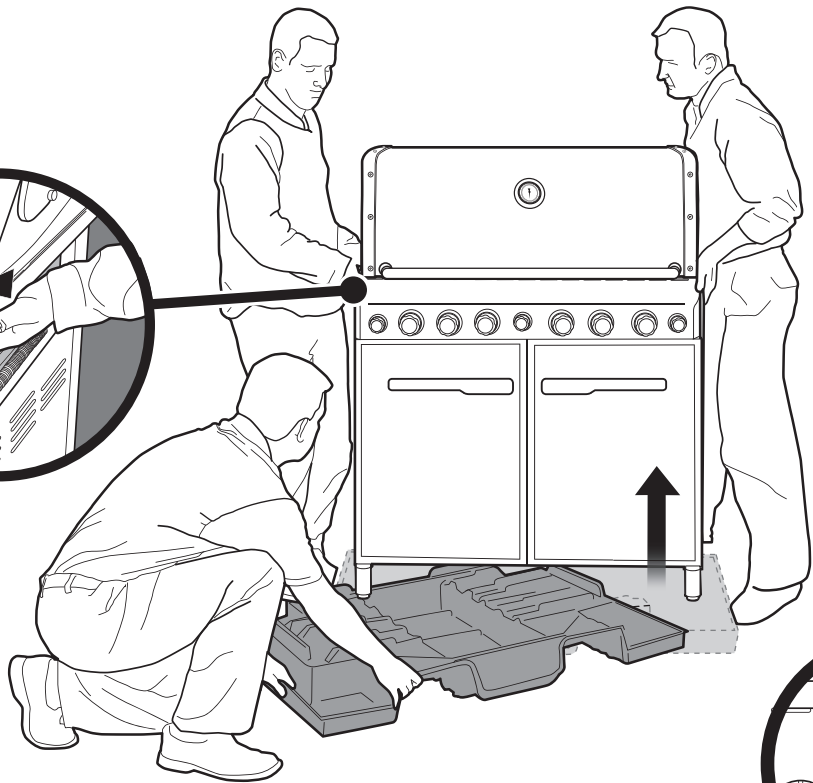
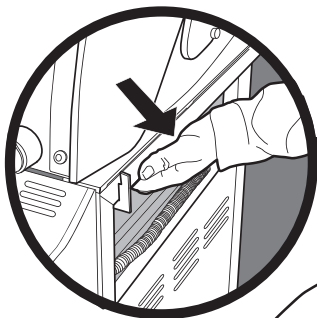

⚠ Remove protective film from all stainless steel surfaces before using grill.

⚠ Retire la película protectora de todas las superficies de acero inoxidable antes de utilizar la barbacoa.

⚠ Retirez la pellicule de protection de toutes les surfaces en acier inoxydable avant d'utiliser le grill.

2

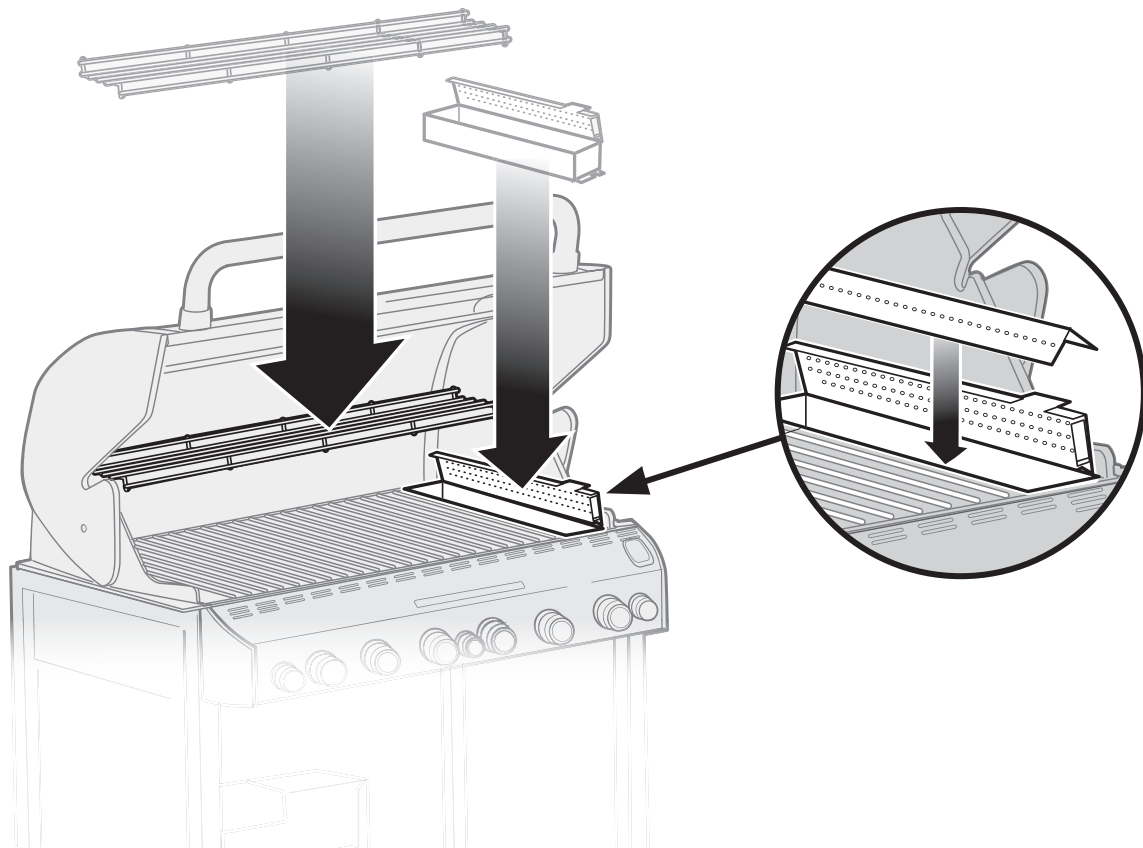
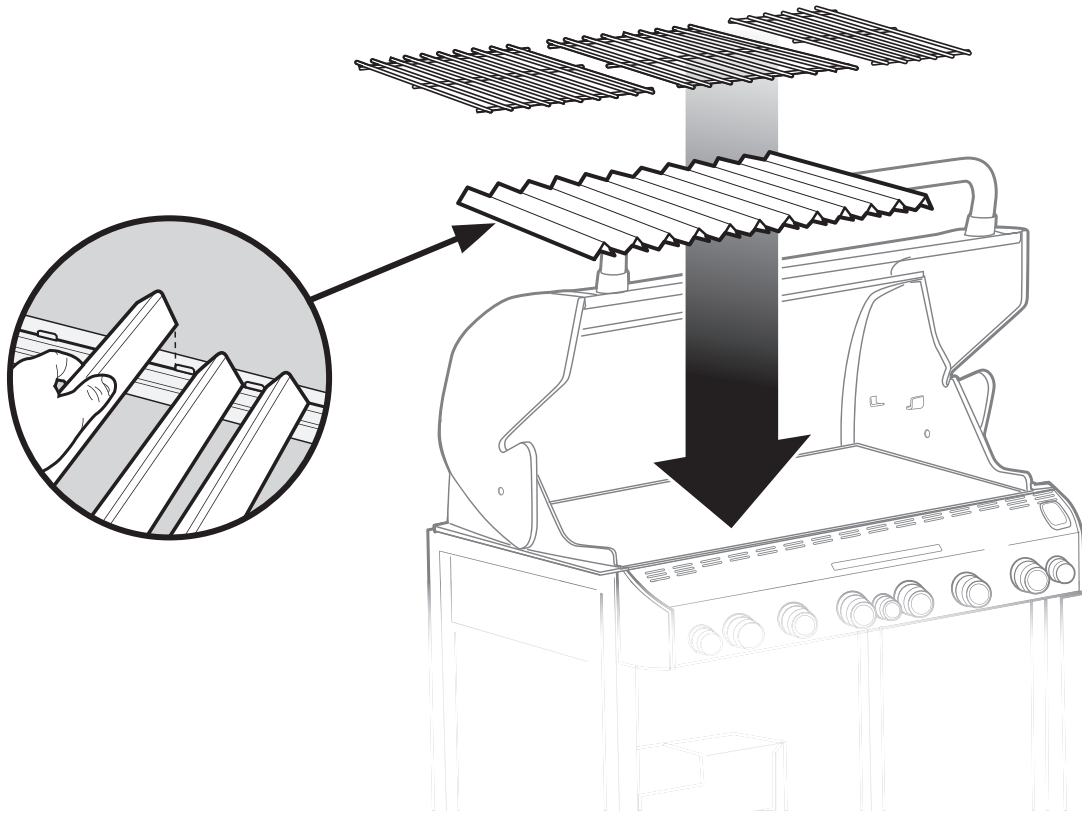

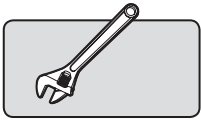
3

Adjust legs on the Main Grilling Unit

Your patio may not be a level surface, which is why your Grill Center is equipped with height-adjustable legs. The legs on the main grilling unit are pre-set to their minimum height of 3/4". You will need to slightly extend these legs, which shall allow levelling adjustments to be made as assembly progresses.

- 1) Use an adjustable wrench and turn clockwise to extend the height-adjustable legs to 1 1/2 inches (38 mm).

⚠ Do not extend legs beyond 1 1/2 inches (38mm).

Ajuste las patas de la Unidad Principal de Asado

La superficie de su patio podría no estar nivelada, por cuya razón el Centro de Asado está equipado con patas de altura ajustable. Las patas en la unidad principal de asado están preajustadas a su nivel mínimo de altura de 3/4 pulg. Necesitará extender ligeramente estas patas, las cuales le permitirán realizar los ajustes de nivelado en la medida que el ensamblaje progrese.

- 1) Use una llave ajustable para girar las patas de altura ajustable en sentido de las agujas del reloj y extenderlas a 1 1/2 pulgada (38 mm).

⚠ No extienda las patas más allá de 1 1/2 pulgada (38 mm).

Ajustez les pieds sur l'Appareil principal pour la grillade

Il est possible que la surface de votre patio ne soit pas plane, c'est pour cela que votre Grill Center est équipé de pieds ajustables en hauteur. Les pieds sur l'Appareil principal pour la grillade sont pré-réglés à leur hauteur minimale de 3/4" (1,90 cm). Vous aurez besoin d'allonger légèrement ces pieds, ce qui permettra des ajustements de mise à niveau au fur et à mesure pendant l'assemblage.

- 1) Utilisez une clé à molette et tournez dans le sens des aiguilles d'une montre pour allonger les pieds ajustables en hauteur jusqu'à 1 1/2 pouces (38 mm).

⚠ N'allongez pas les pieds au-delà de 1 1/2 pouces (38 mm).

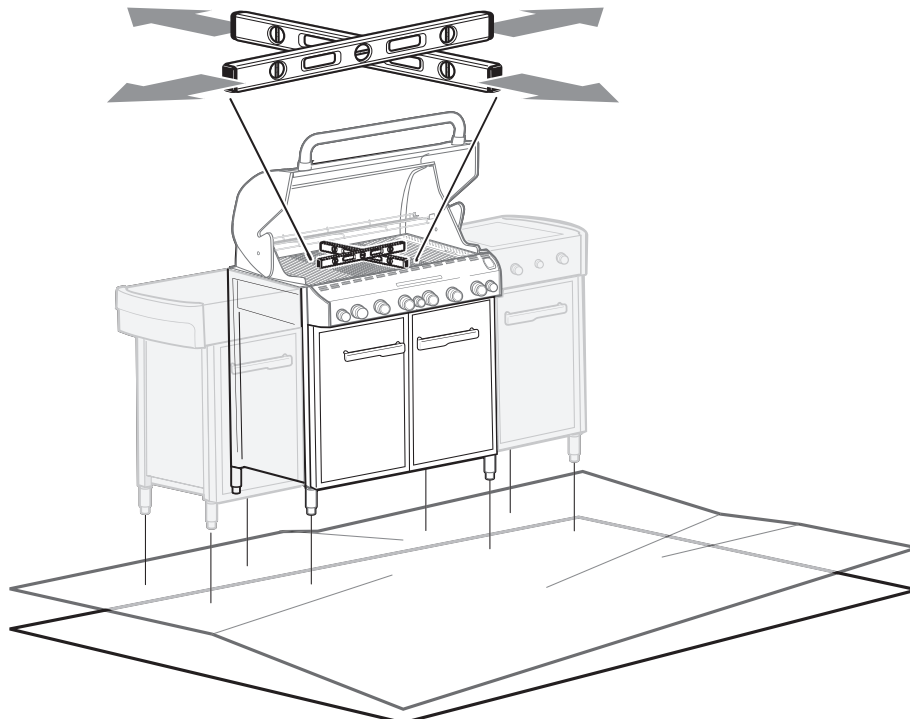
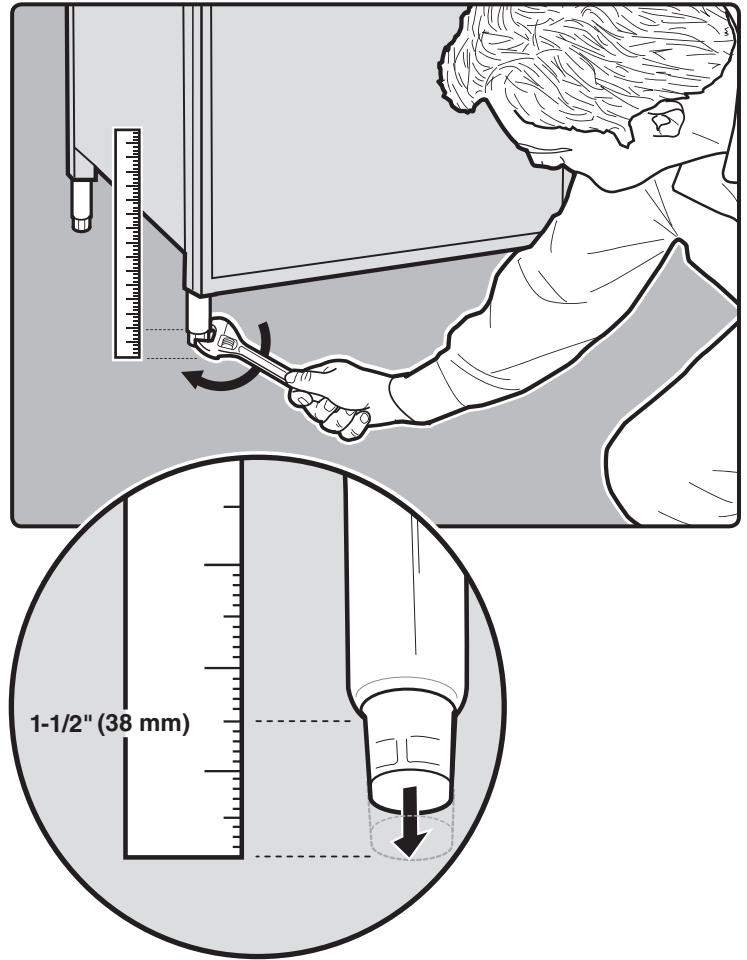

⚠ Be sure to level Main Grilling Unit front to back and side to side. Use cooking grates as levelling surface. Make further adjustments to legs (if necessary).

⚠ Asegúrese de nivelar la Unidad Principal de Asado de atrás hacia adelante y de lado a lado. Utilice las parrillas de cocción como superficie de nivelación. Si fuese necesario, haga más ajustes a las patas.

⚠ Assurez-vous de mettre à niveau l'Appareil principal pour la grillade d'avant en arrière ainsi que latéralement. Utilisez les grilles de cuisson comme surface de nivelage. Effectuez des ajustements supplémentaires sur les pieds (si nécessaire).

4

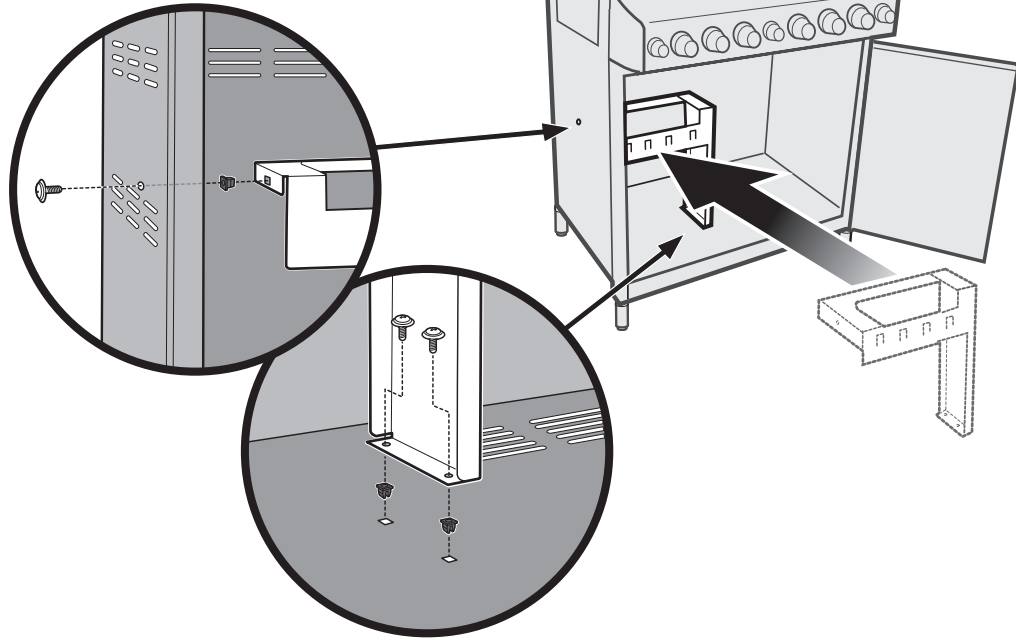
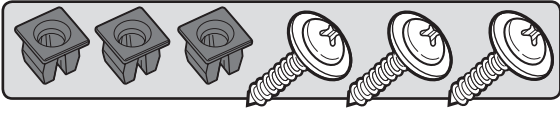

5

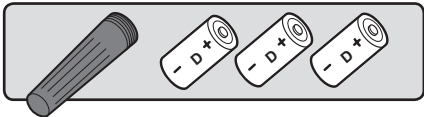

A

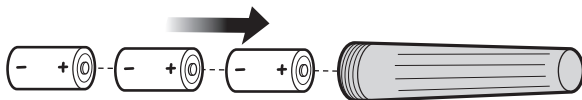

Requires 3 "D" alkaline batteries (included). Use alkaline batteries only. Do not mix old and new batteries or different types of batteries (standard, alkaline, or rechargeable).

Requiere 3 baterías alcalinas "D" (incluidas). Use solamente baterías alcalinas. No mezcle baterías nuevas con viejas o diferentes tipos de baterías entre sí (normales, alcalinas o recargables).

Nécessite 3 piles alcalines "D" (fournies). Utilisez des piles alcalines uniquement. Ne mélangez pas des piles usagées et des piles neuves ou différents types de piles (standards, alcalines, or rechargeables).

B

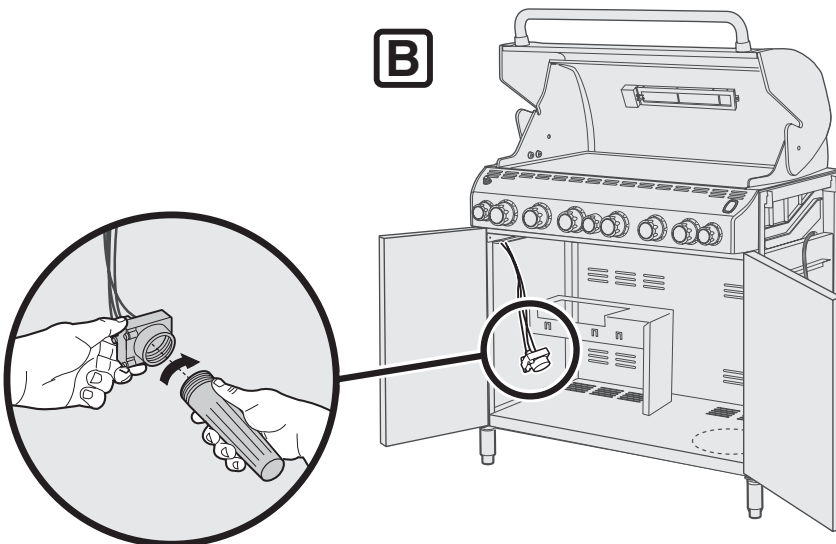

C

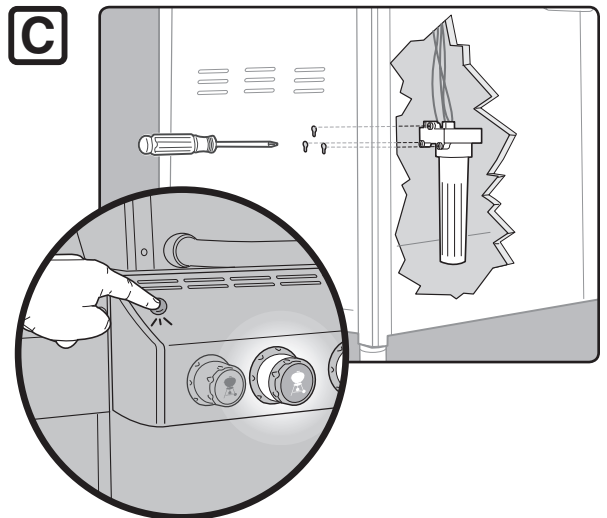

LEFT CABINET ASSEMBLY

ENSAMBLAJE DEL GABINETE IZQUIERDO • ASSEMBLAGE DU MEUBLE DE GAUCHE

6

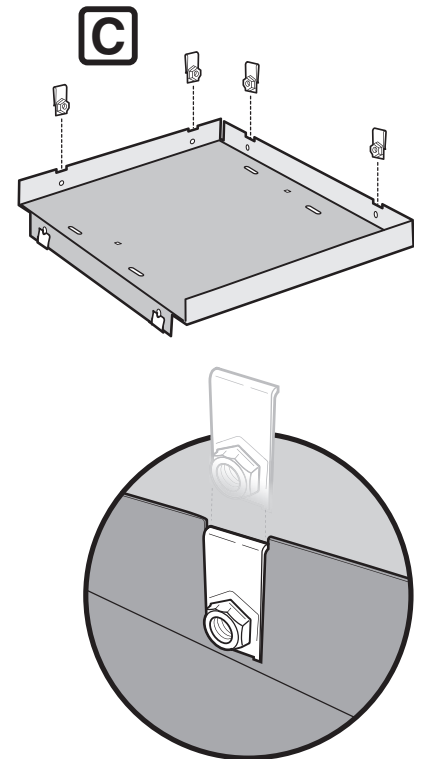
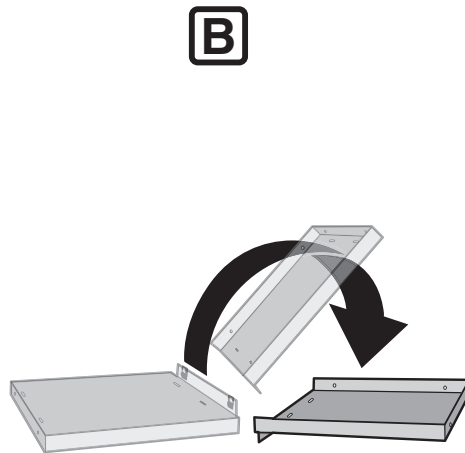
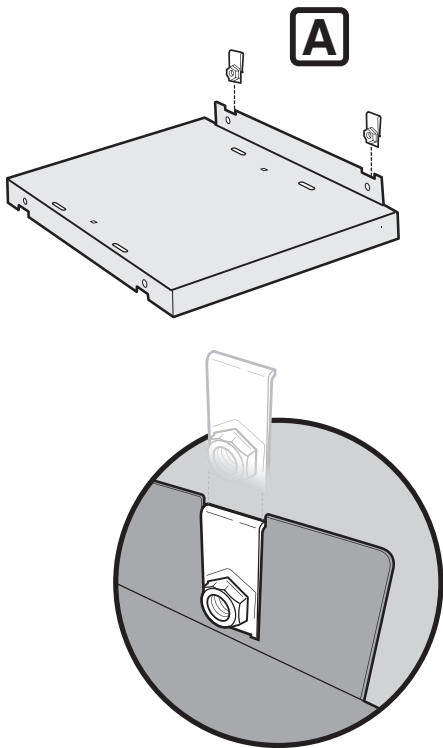
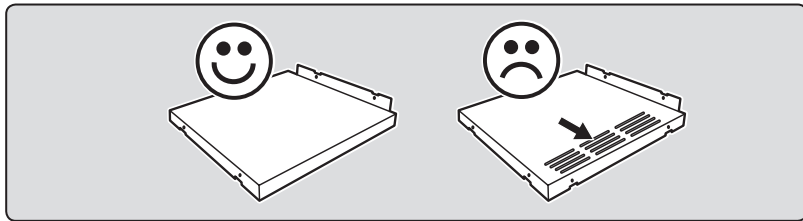
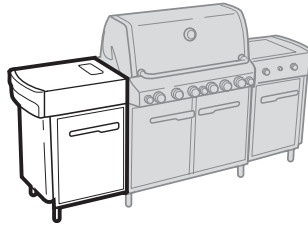
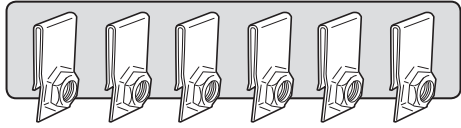

7

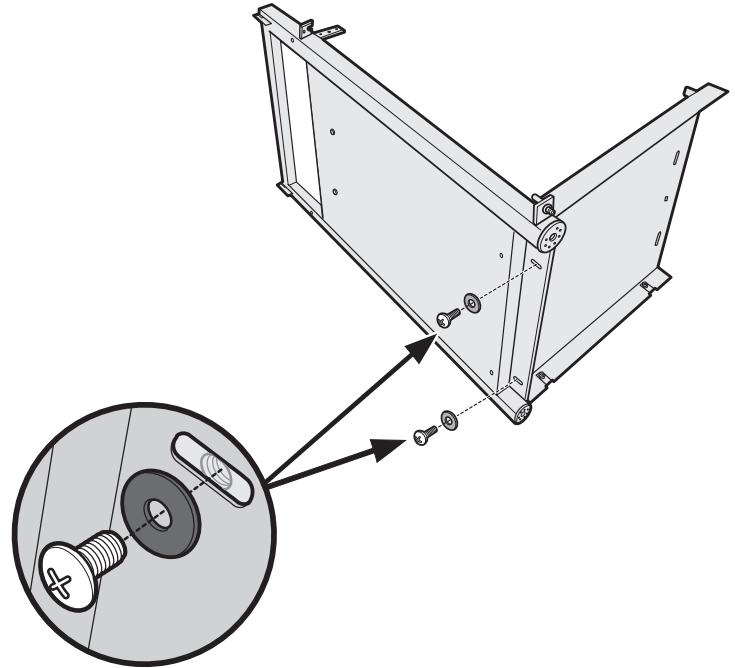
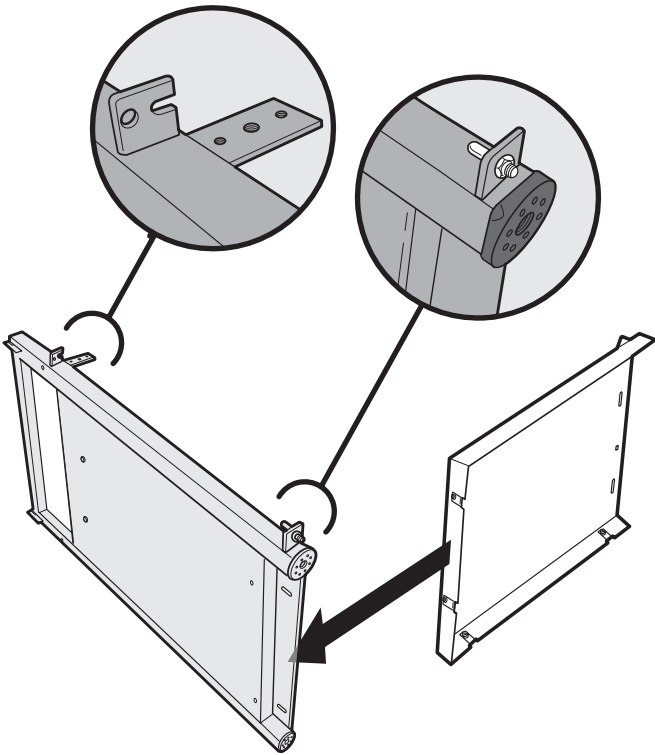
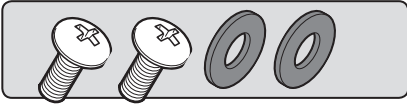

8

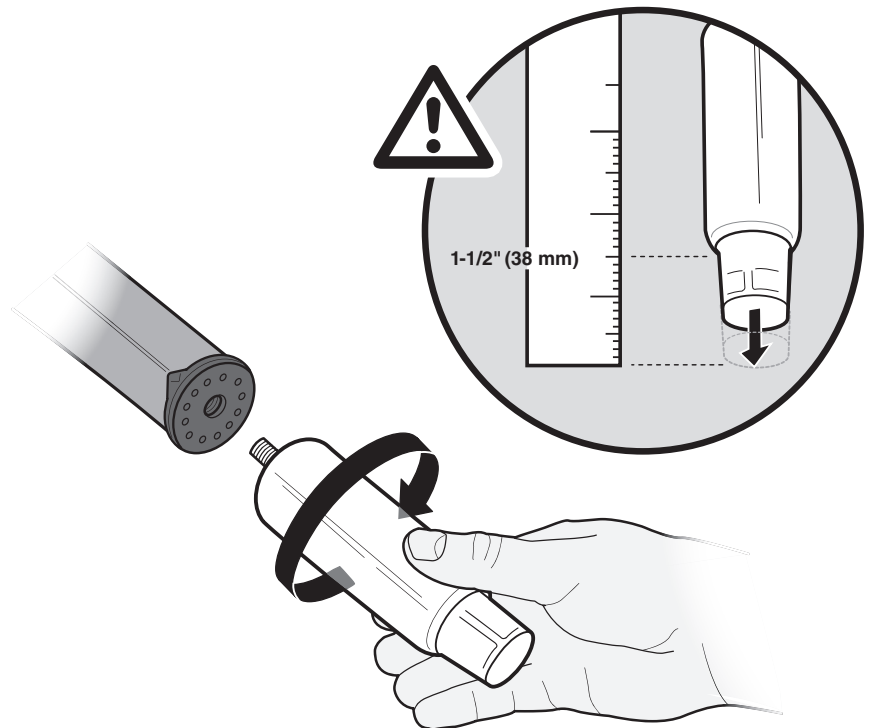
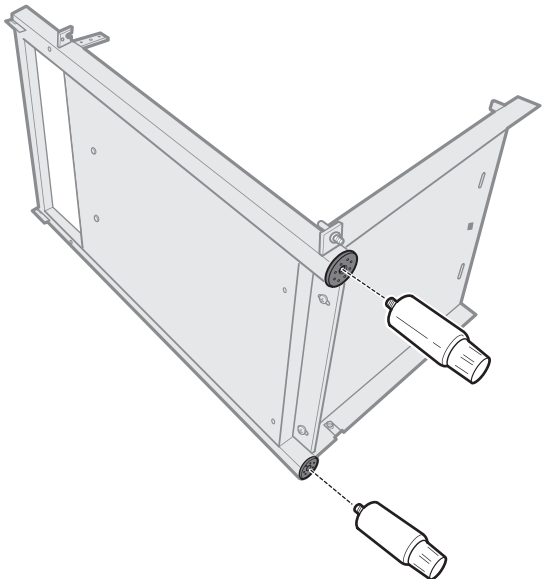

9

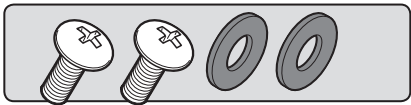

2- 

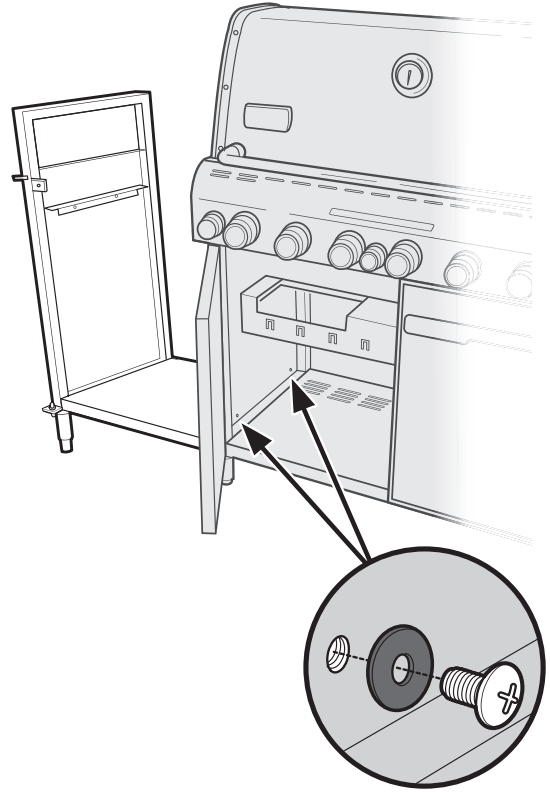
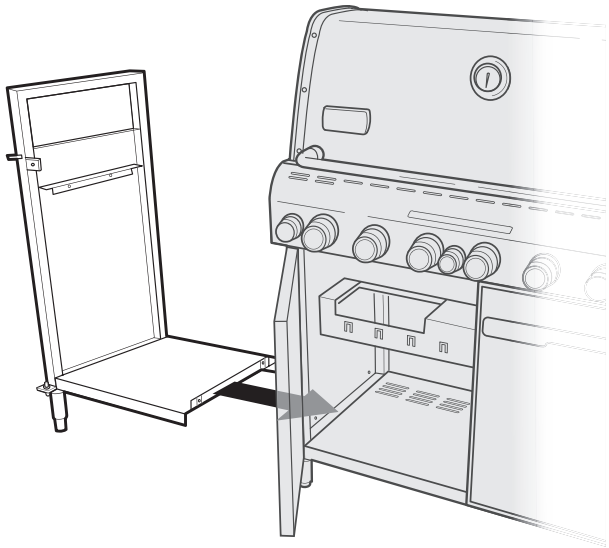

10

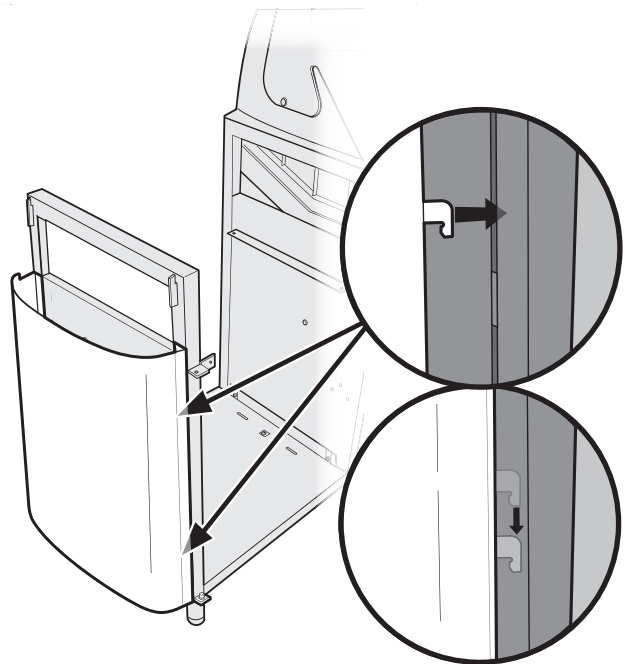
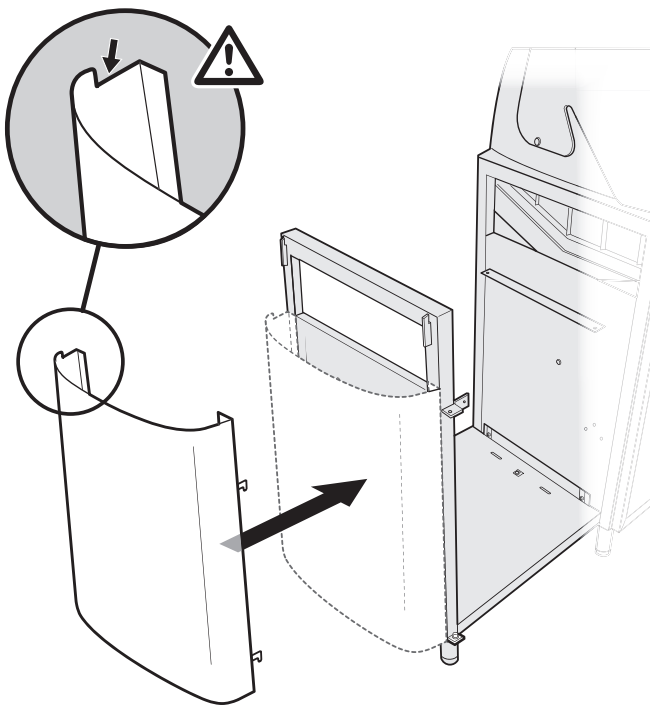

11

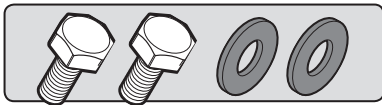

2-

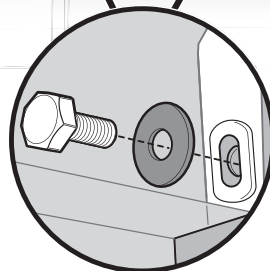
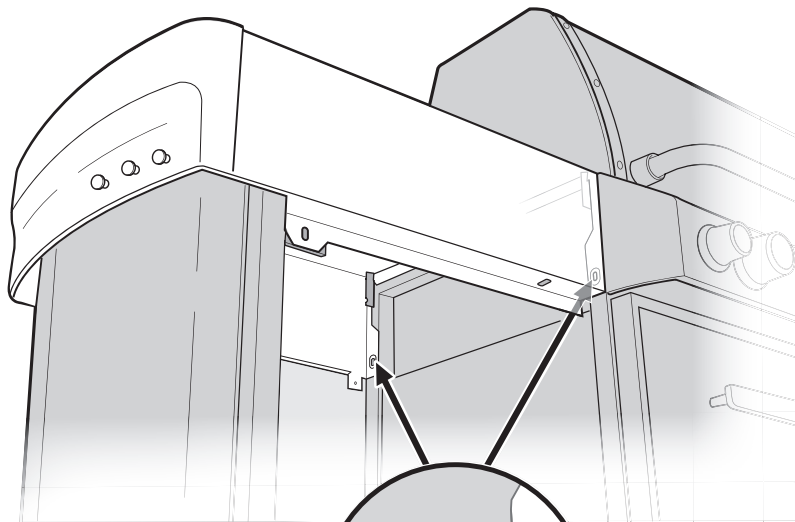
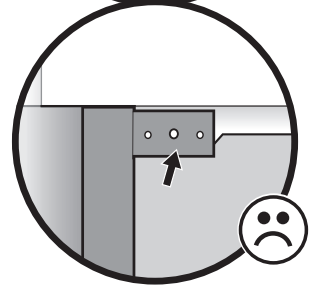
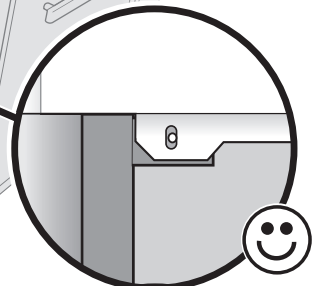
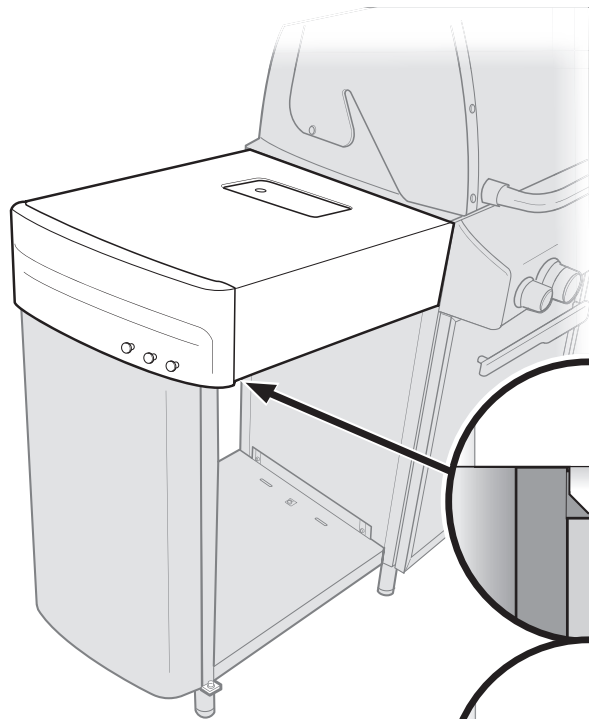
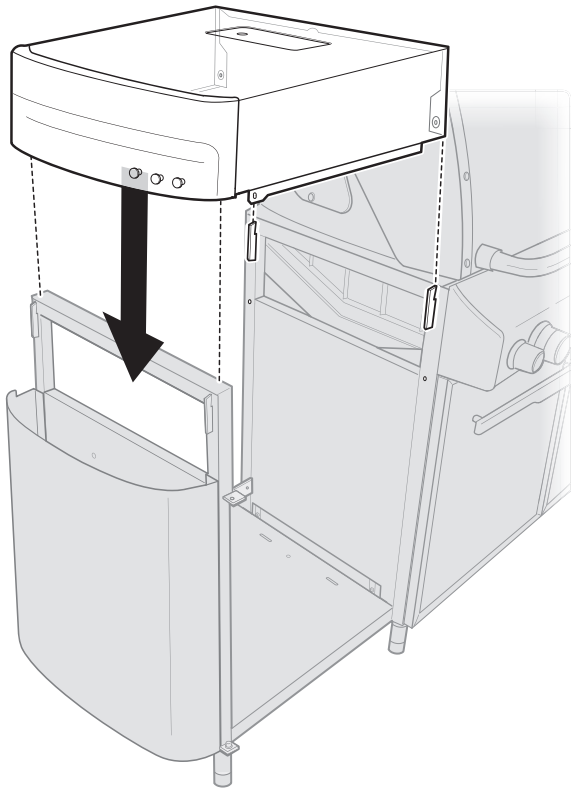

12

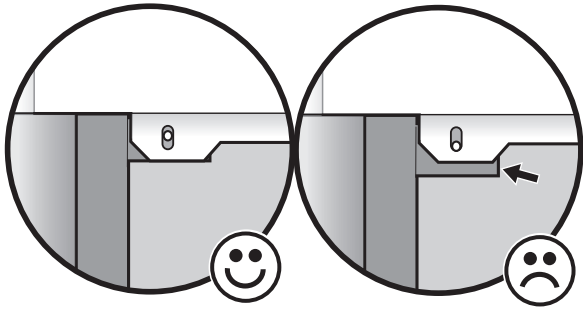
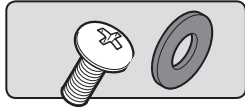

Bottom edge of stainless steel tab must align with frame tab. Adjust the Left Cabinet legs to achieve proper tab alignment (if necessary).

El borde inferior de la pestaña de acero inoxidable debe quedar alineada con la pestaña del bastidor. Ajuste las patas izquierdas del gabinete para lograr alinear correctamente la pestaña (si fuese necesario).

L'extrémité inférieure de la languette en acier inoxydable doit s'aligner avec la languette du cadre. Ajustez les pieds du meuble de gauche afin de réaliser un alignement correct de la languette (si nécessaire).

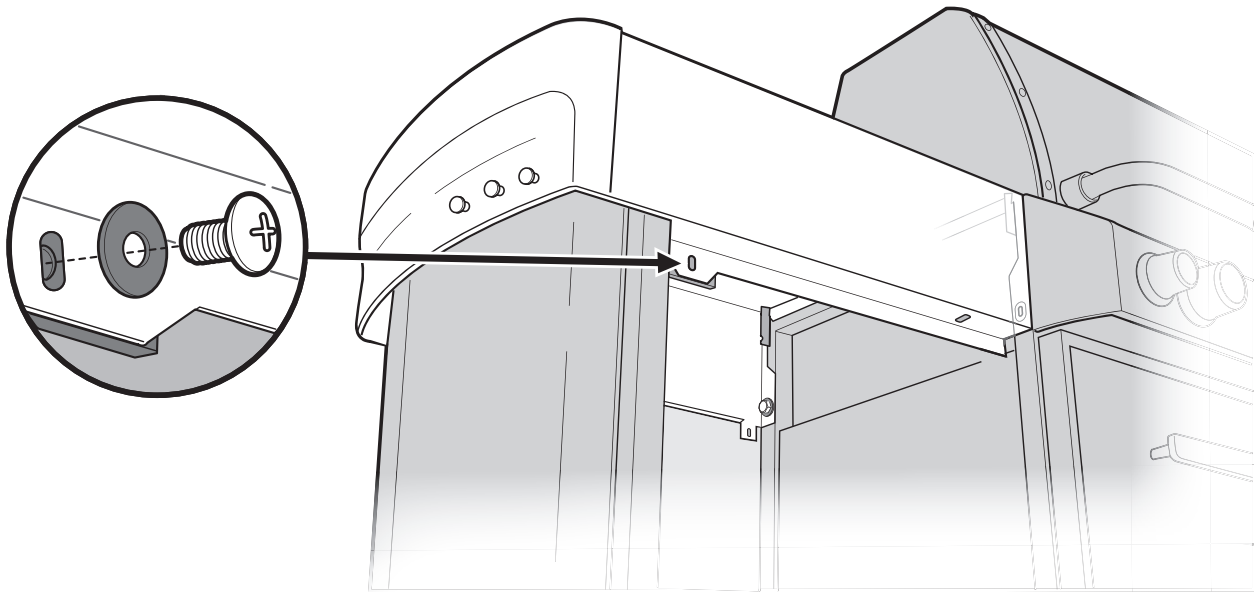
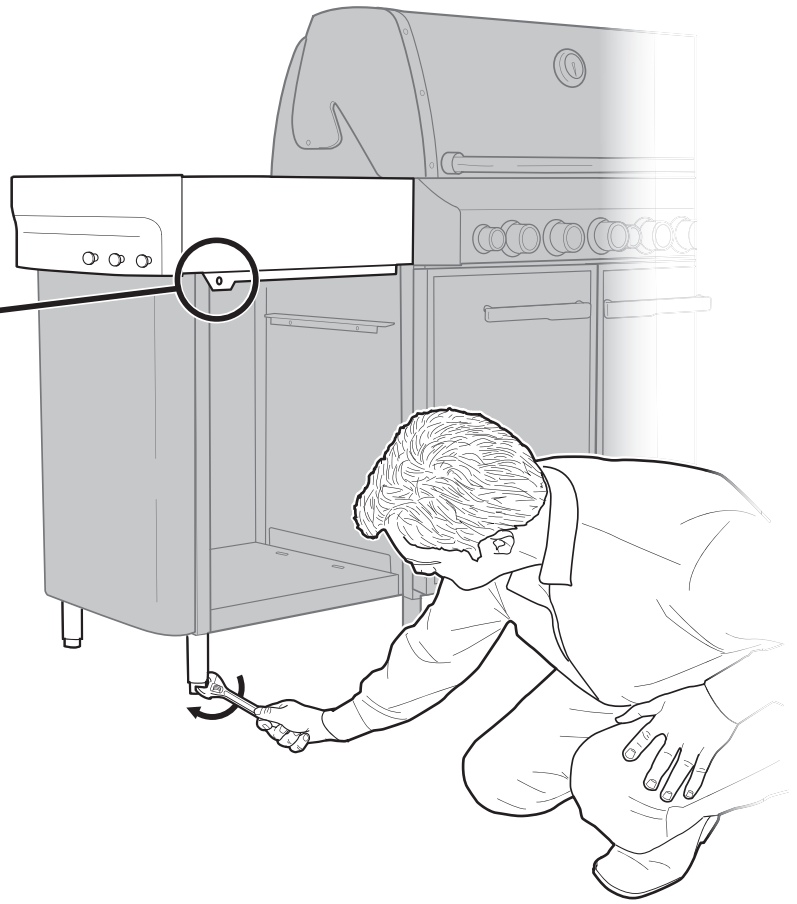

13

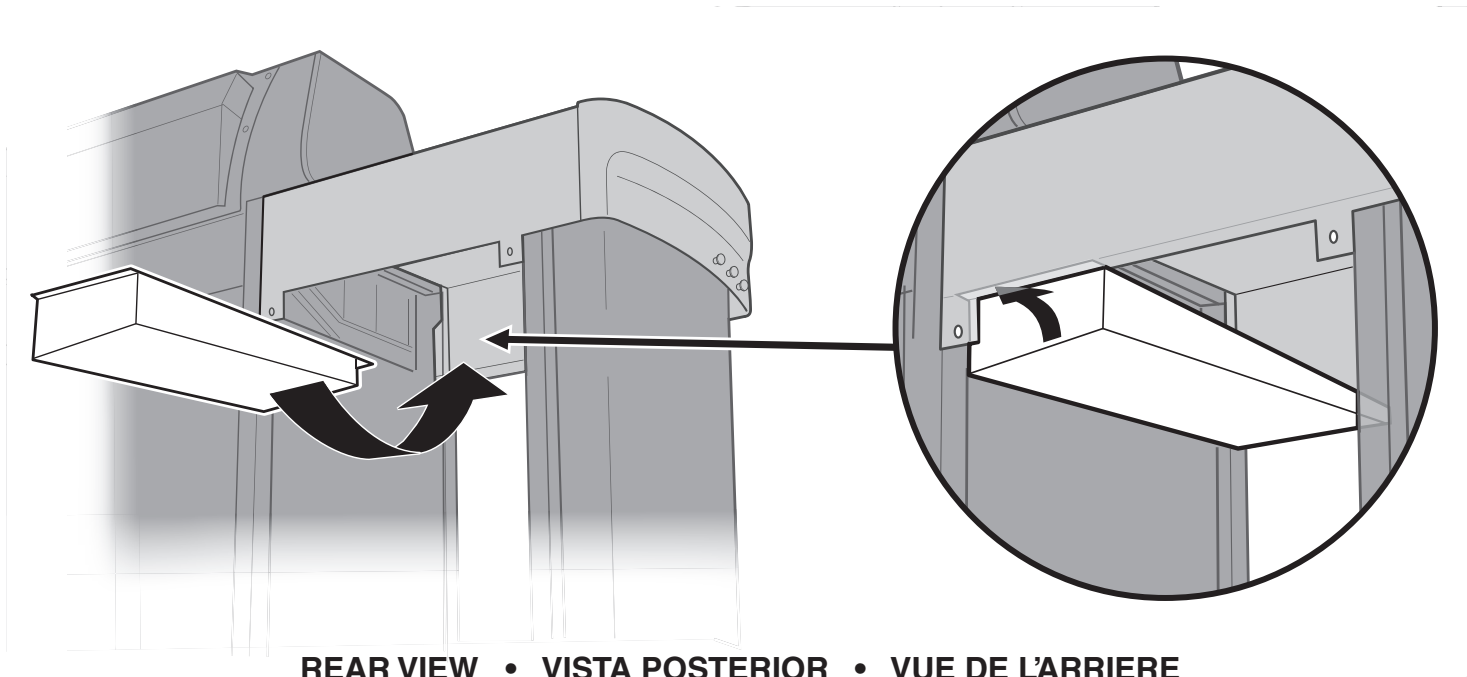
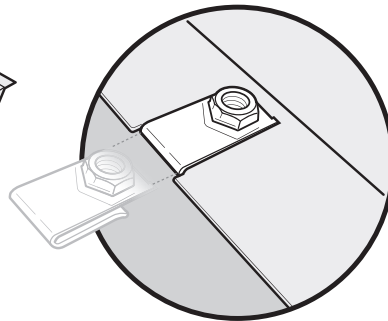
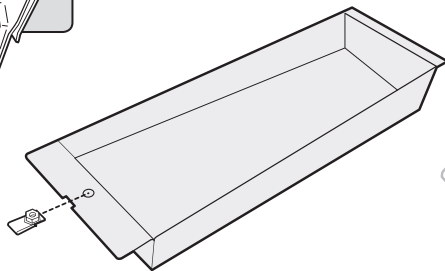
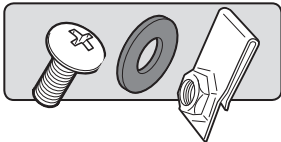

REAR VIEW • VISTA POSTERIOR • VUE DE L'ARRIERE

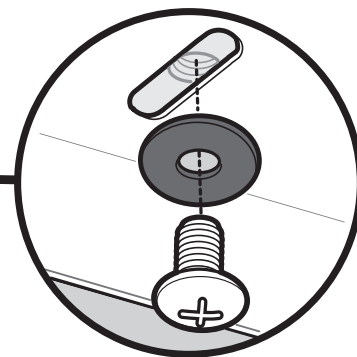
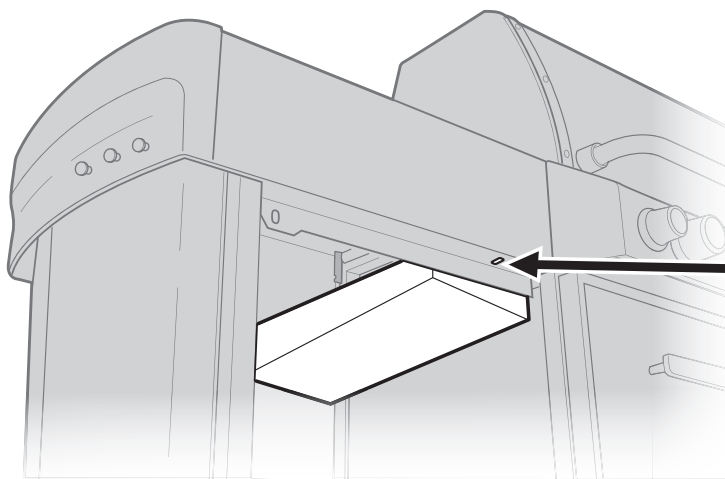

FRONT VIEW • VISTA FRONTAL • VUE DE L'AVANT

14

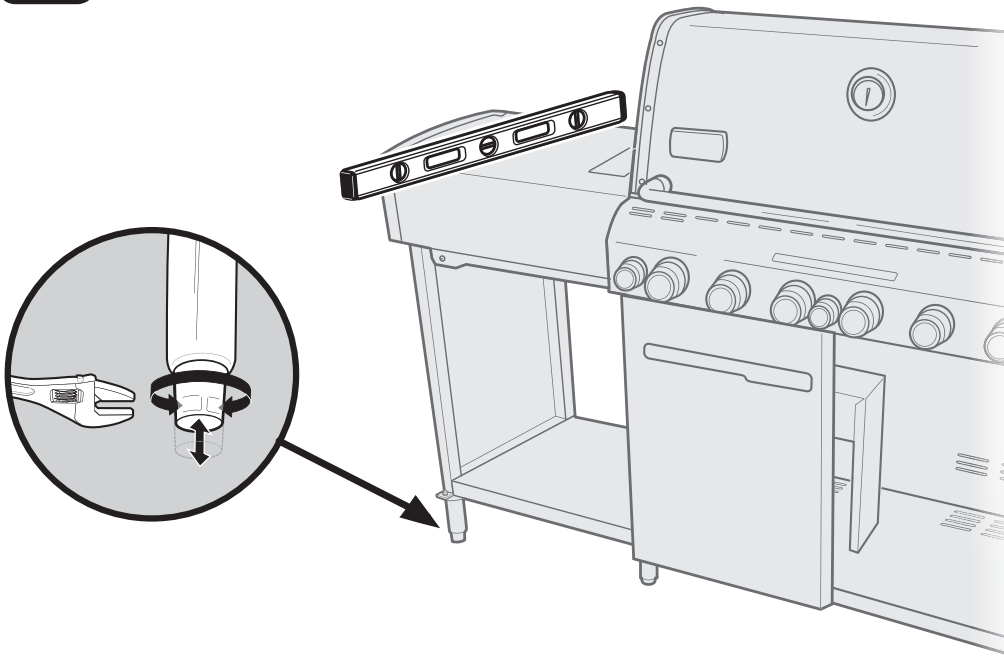

Level the Left Cabinet front to back and side to side.

Nivele el Gabinete Izquierdo de adelante hacia atrás y de lado a lado.

Mettez à niveau le Meuble de gauche d'avant en arrière ainsi que latéralement.

15

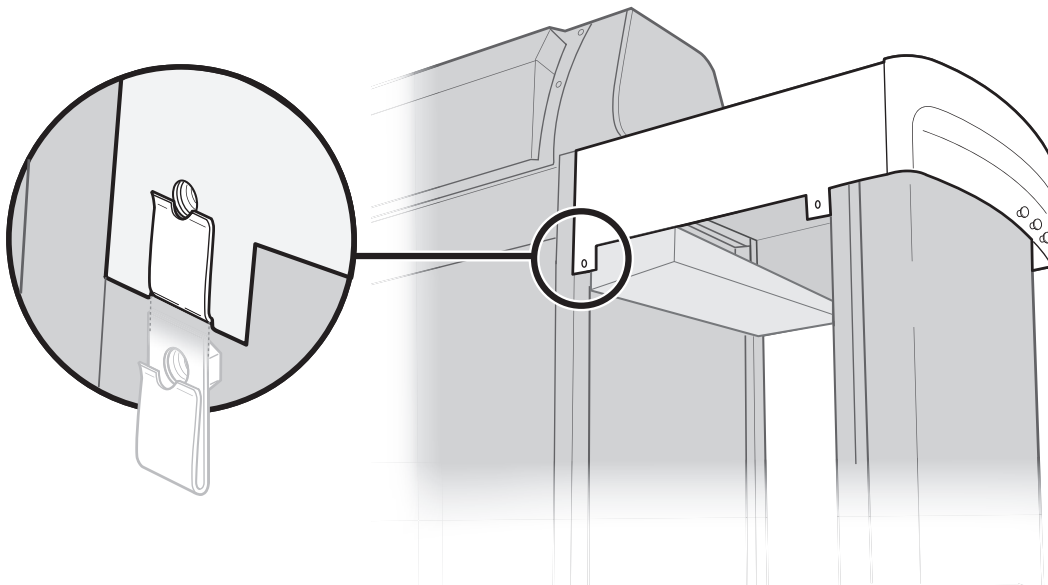
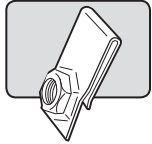

REAR VIEW • VISTA POSTERIOR • VUE DE L'ARRIERE

16

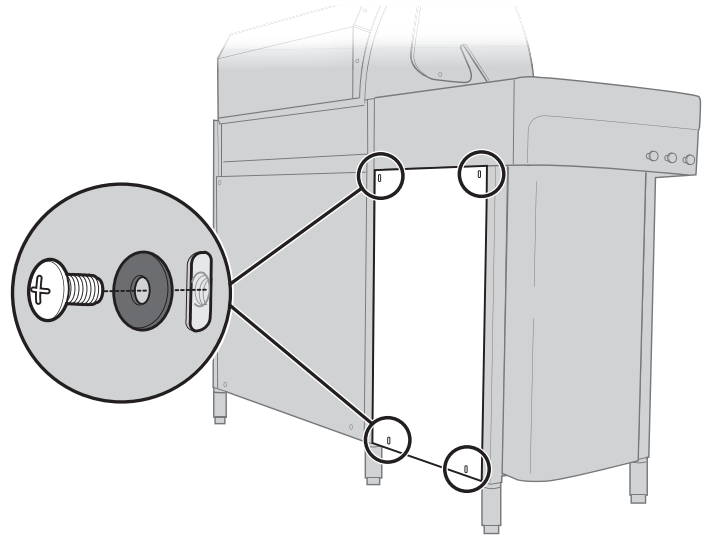
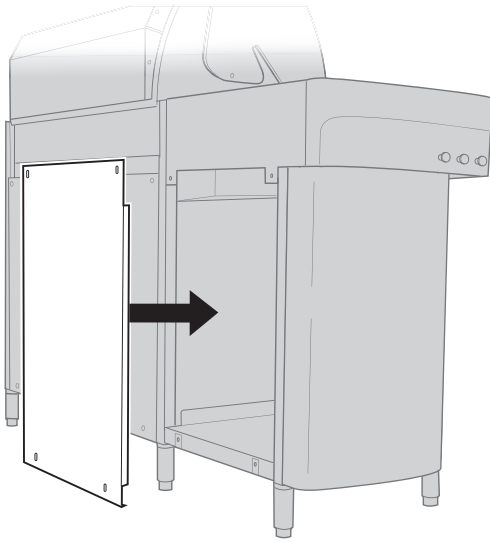
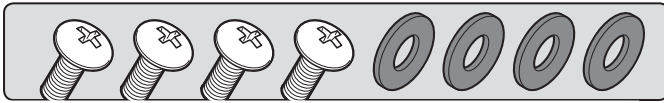

SIDEBURNER CABINET ASSEMBLY

ENSAMBLAJE DEL GABINETE DEL QUEMADOR LATERAL
ASSEMBLAGE DU MEUBLE DU BRULEUR LATERAL

17

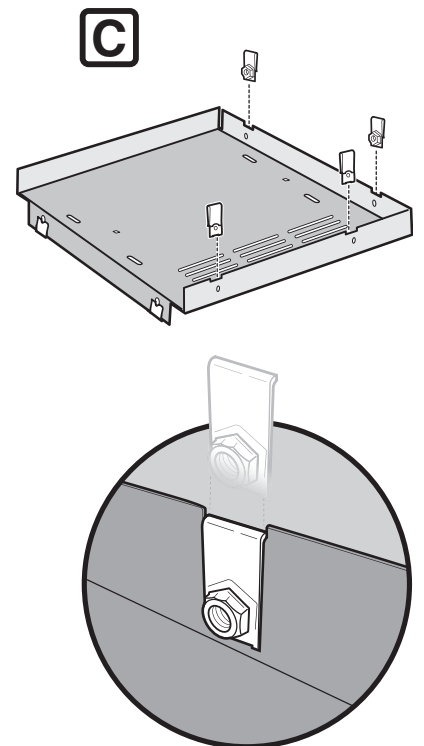
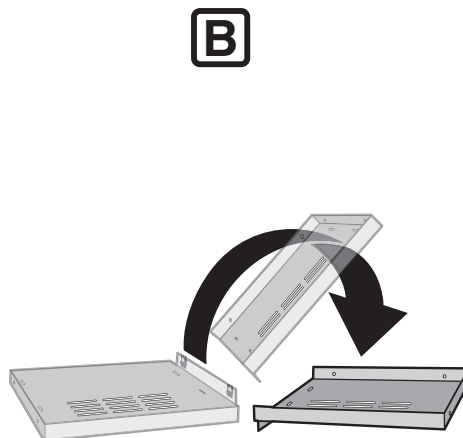
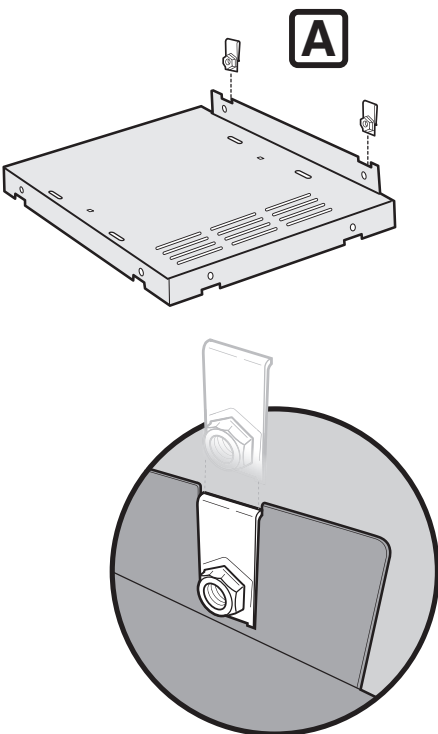
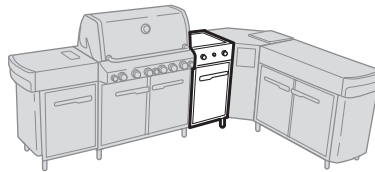
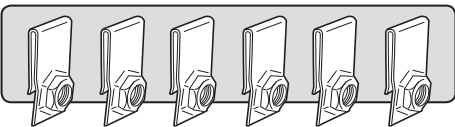

18

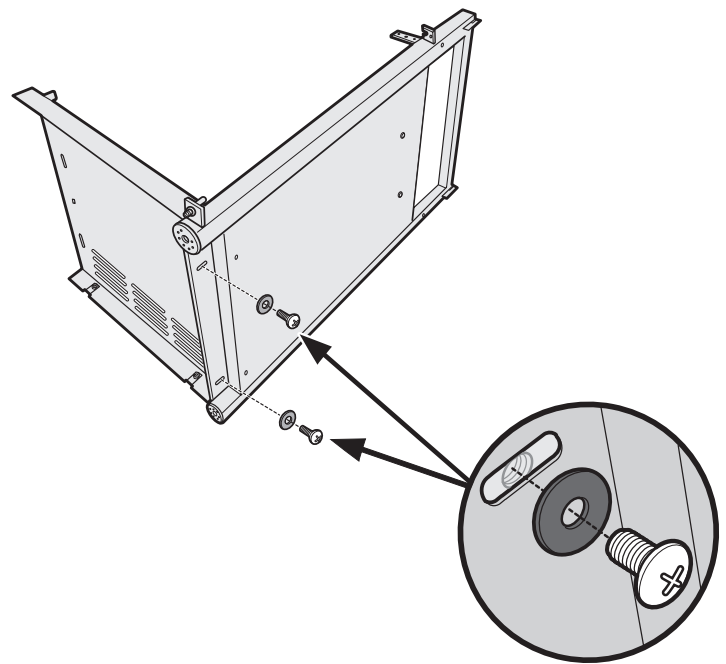
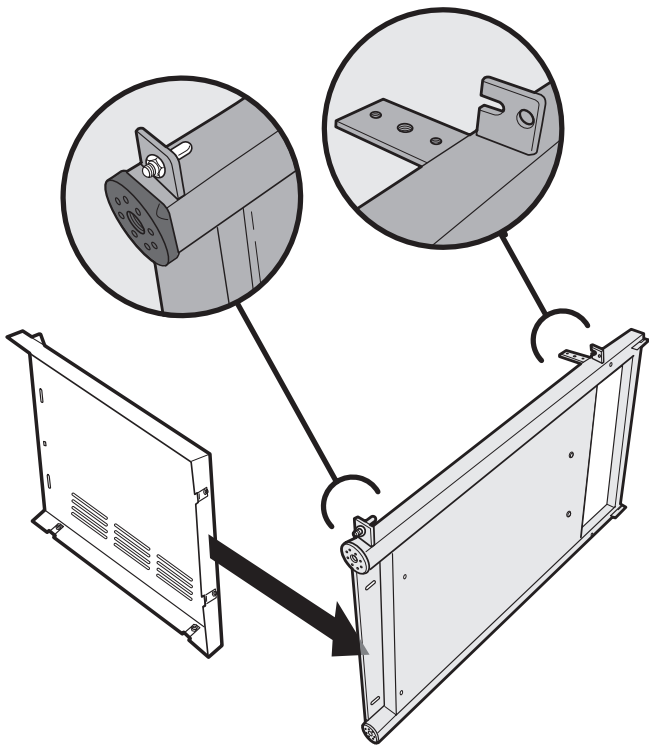
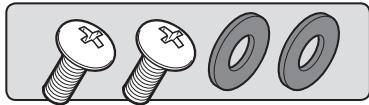

19

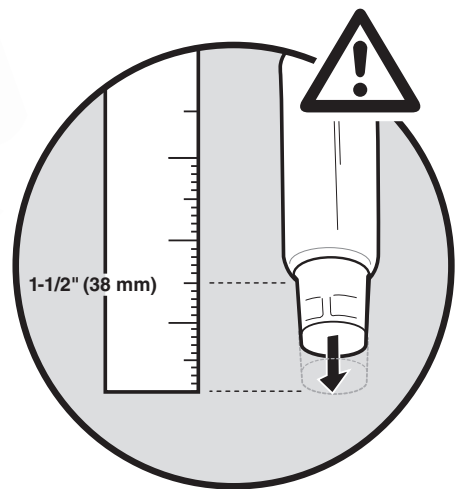
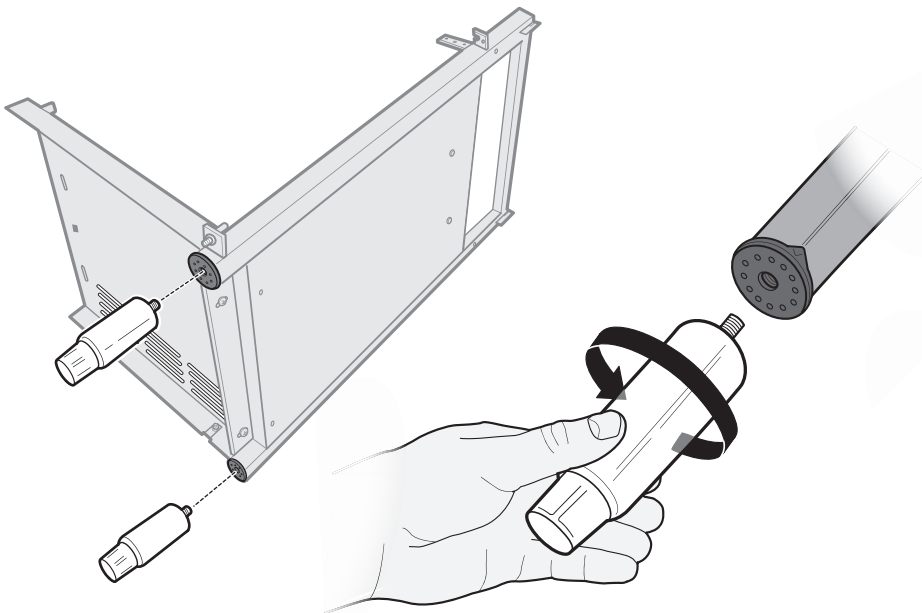

20

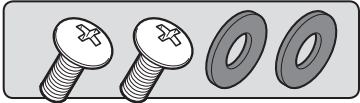

2- 

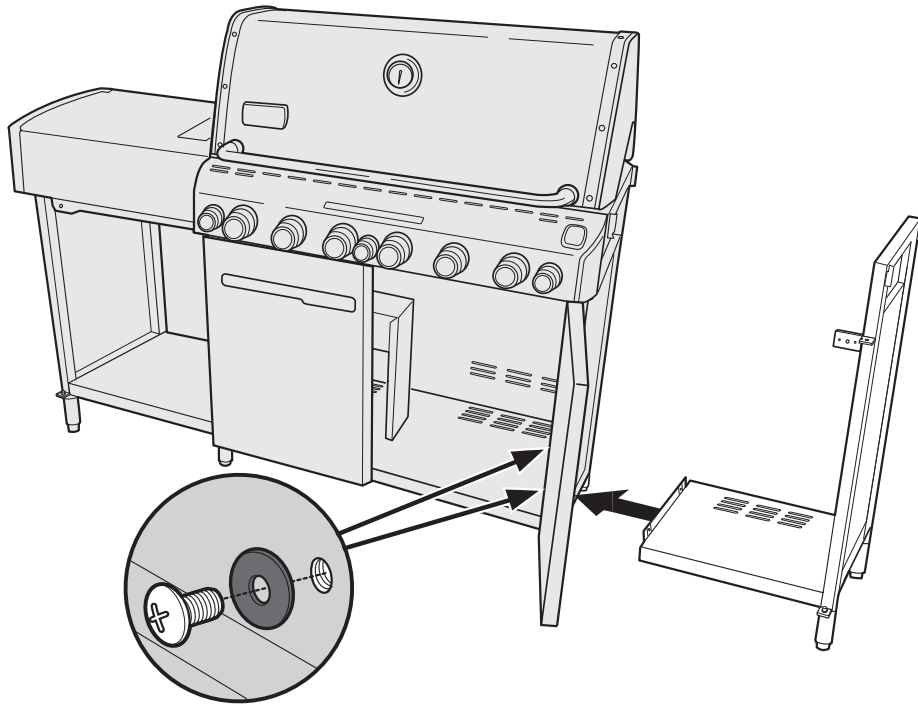

21

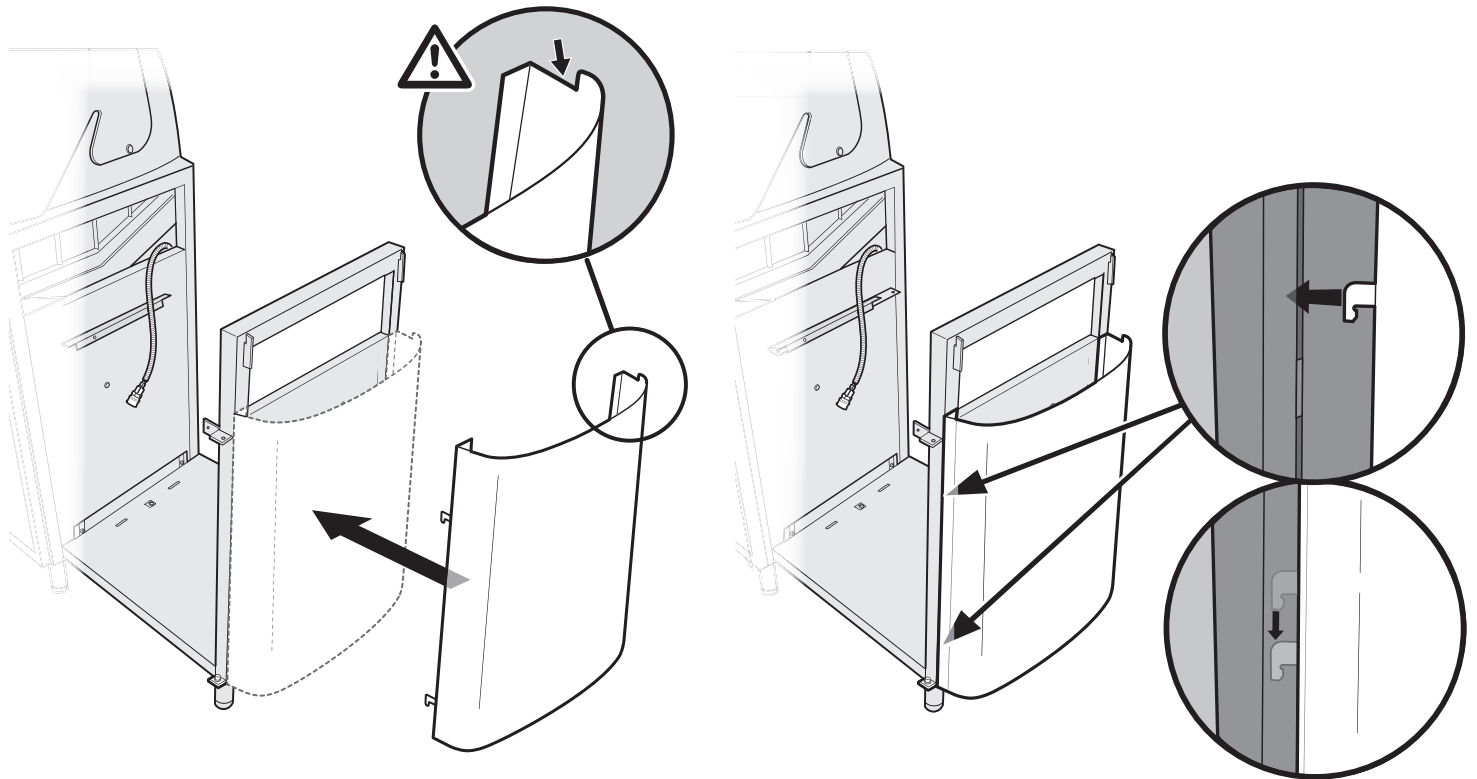

22

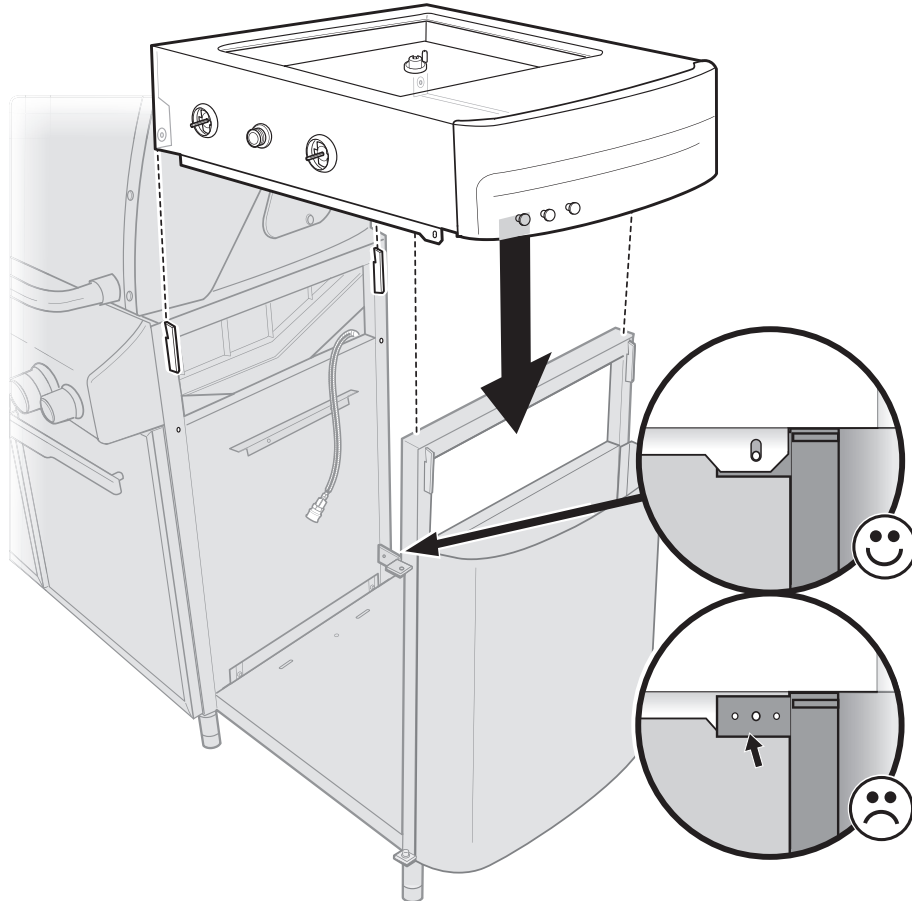

23

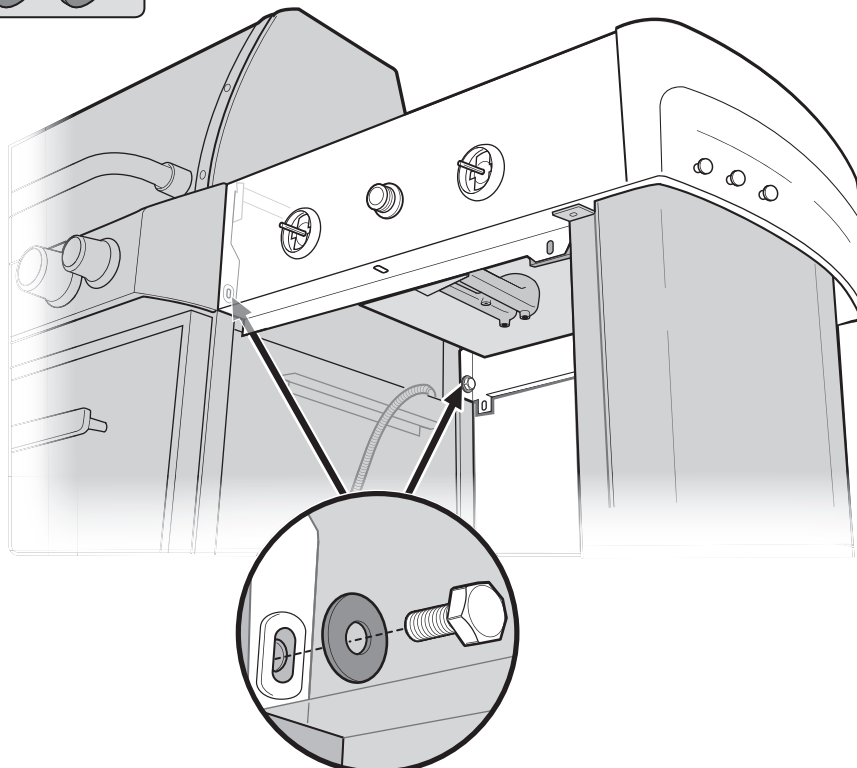
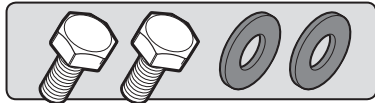

24

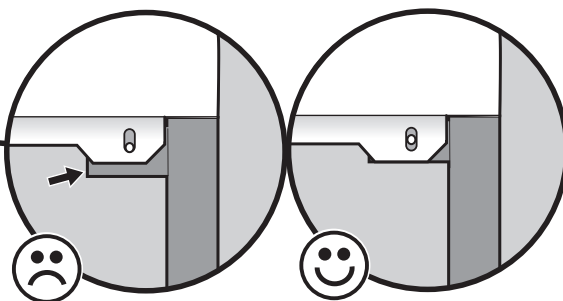
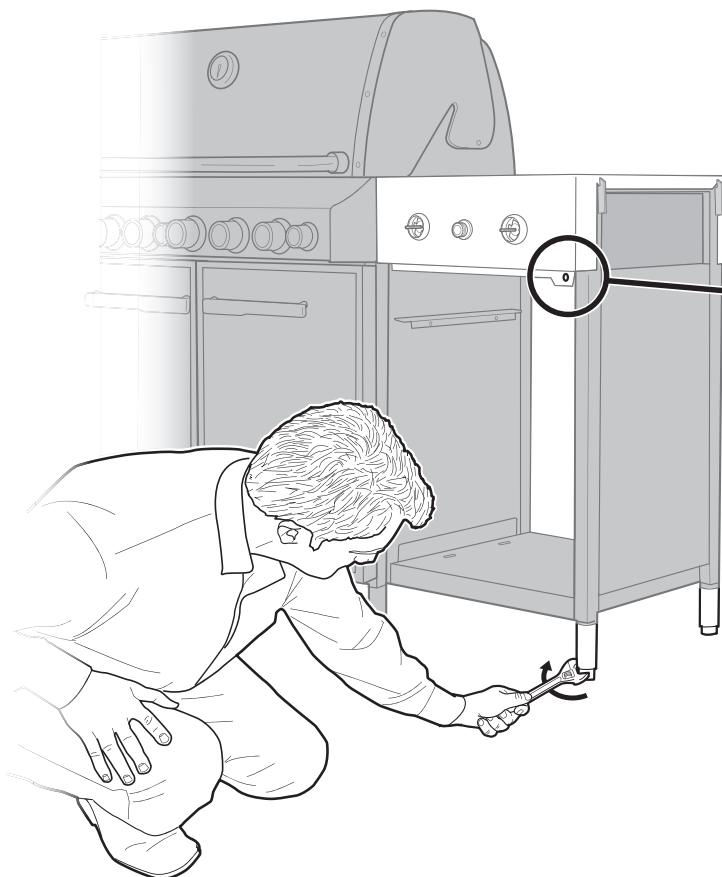

Bottom edge of stainless steel tab must align with frame tab. Adjust the Side Burner Cabinet legs to achieve proper tab alignment (if necessary).

El borde inferior de la pestaña de acero inoxidable debe quedar alineada con la pestaña del bastidor. Ajuste las patas del Gabinete del Quemador Lateral para lograr alinear correctamente la pestaña (si fuese necesario).

L'extrémité inférieure de la languette en acier inoxydable doit s'aligner avec la languette du cadre. Ajustez les pieds du Meuble du brûleur latéral afin de réaliser un alignement correct de la languette (si nécessaire).

25

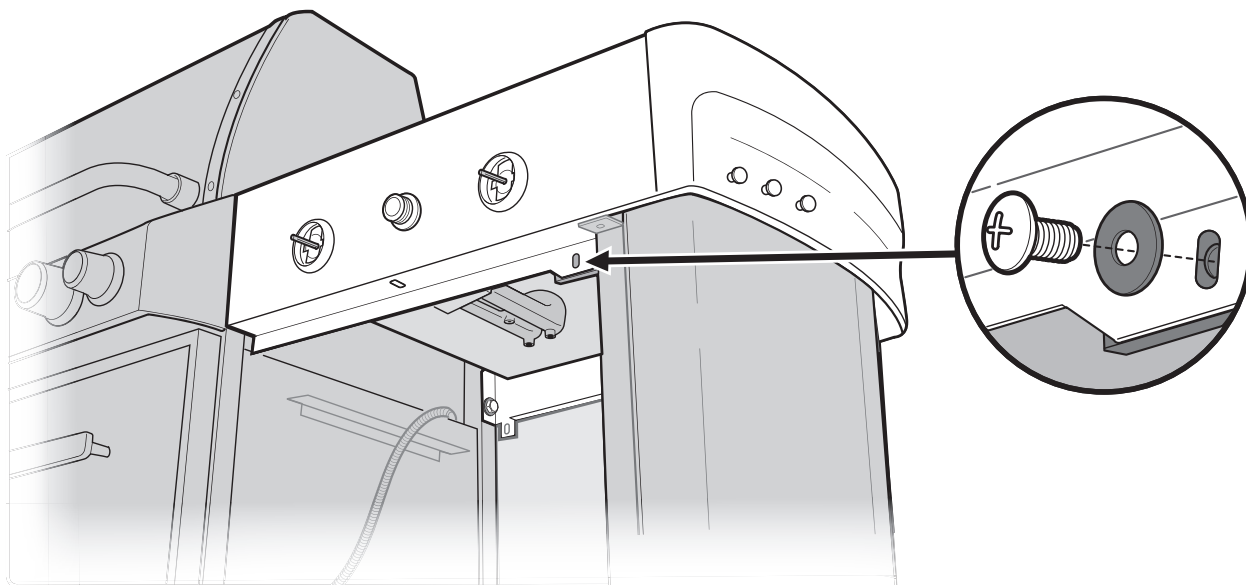
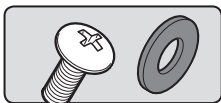

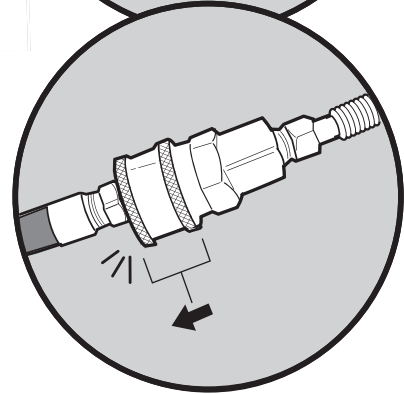
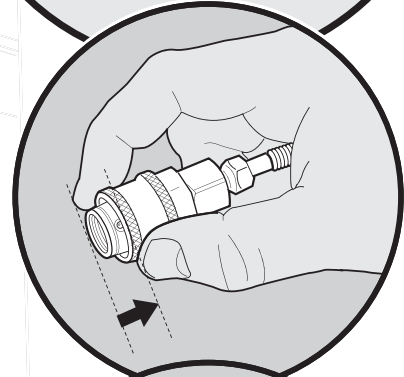
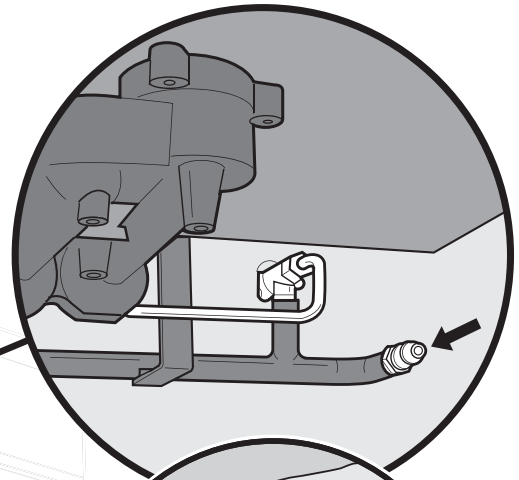
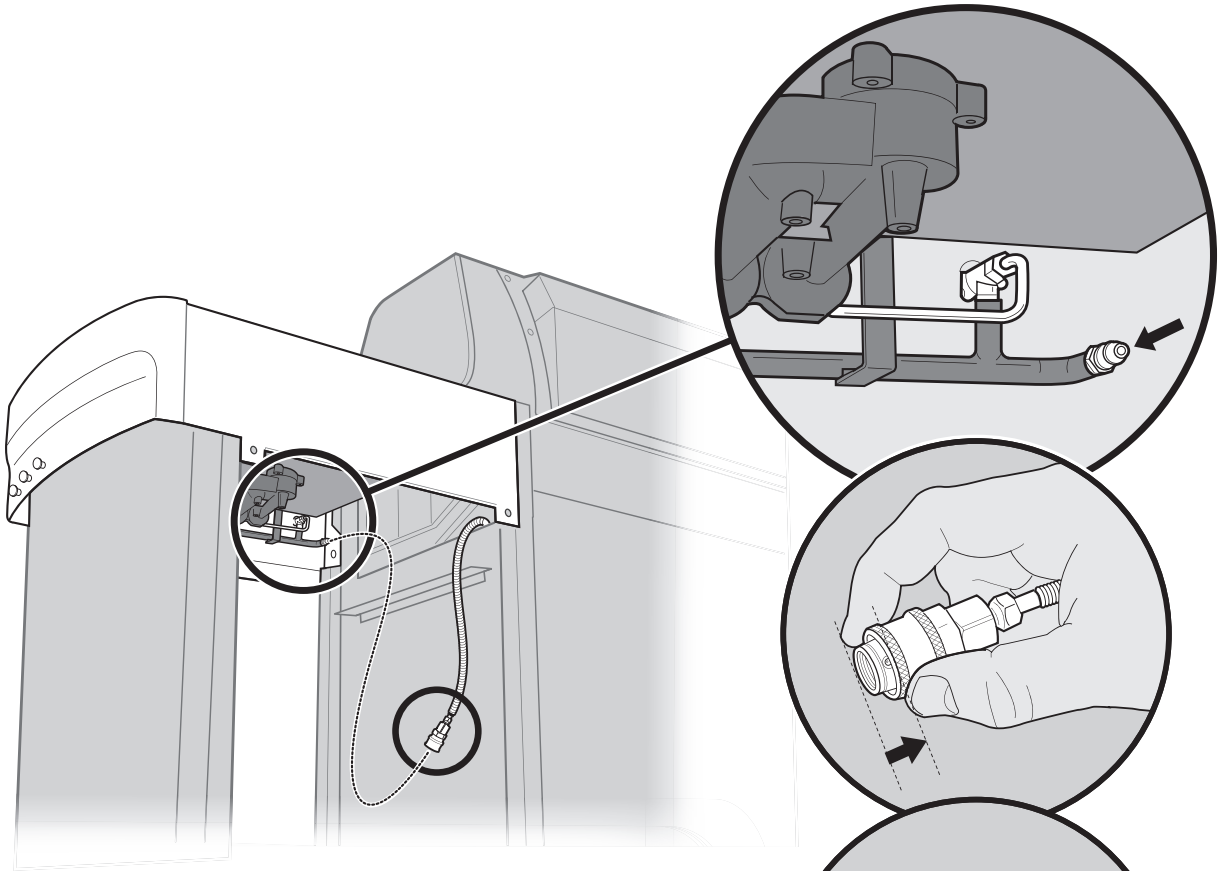

REAR VIEW
VISTA POSTERIOR
VUE DE L'ARRIERE

27

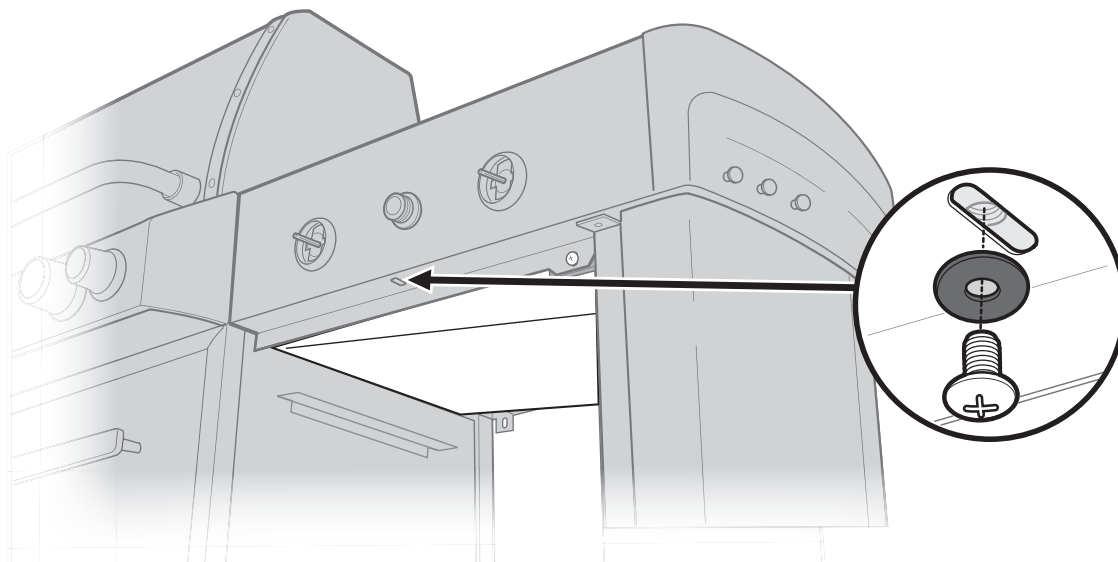
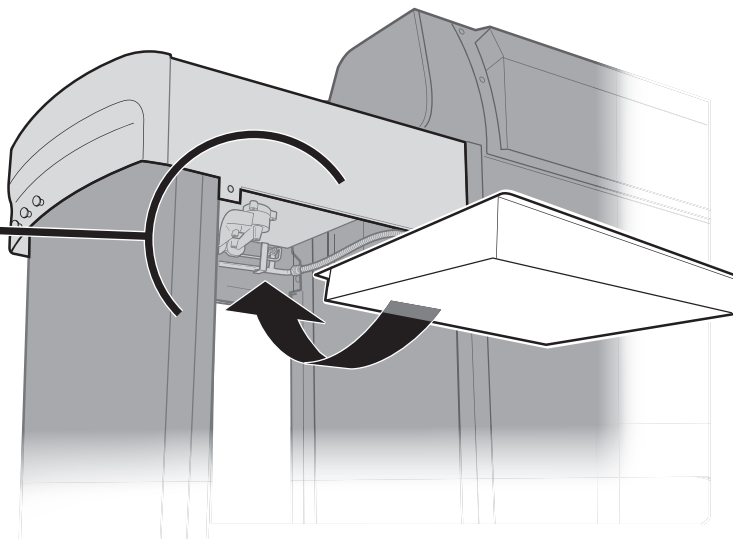
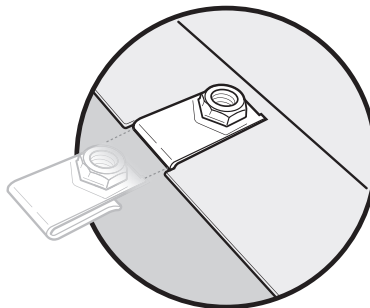
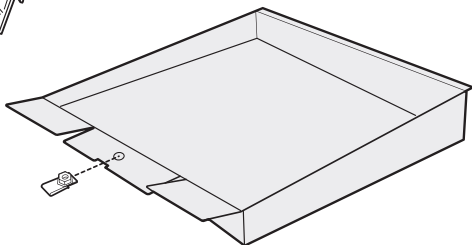
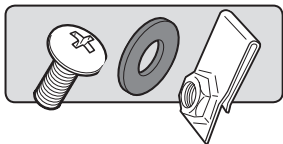

FRONT VIEW • VISTA FRONTAL • VUE DE L'AVANT

28

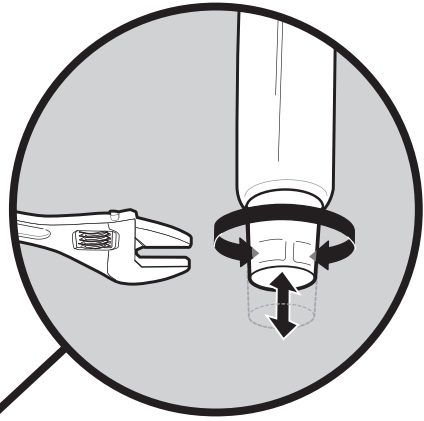
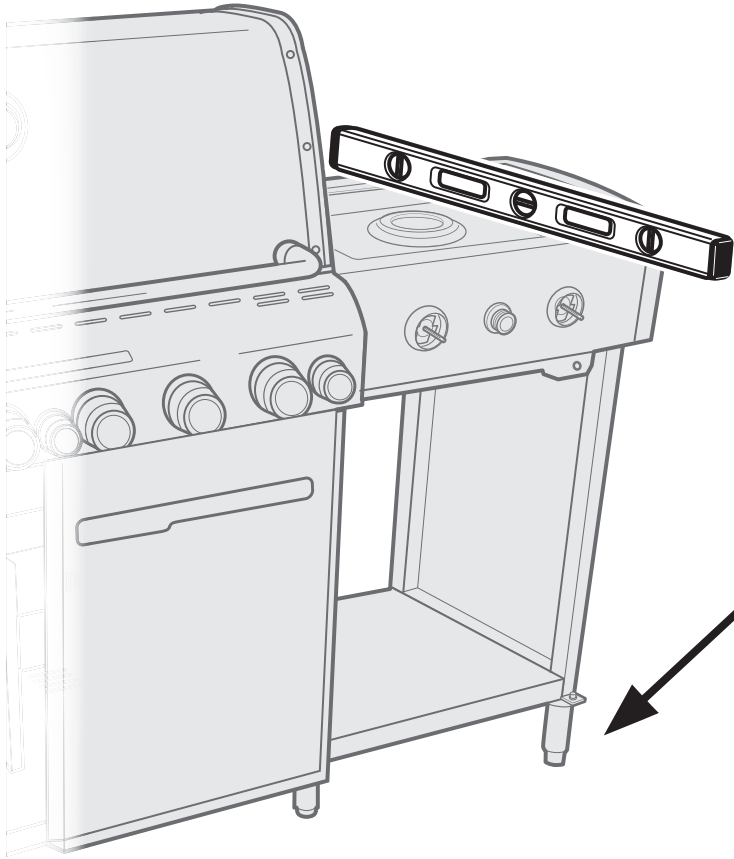

Adjust legs, if necessary.
Si fuese necesario, ajuste las patas.
Ajustez les pieds, si nécessaire.

29

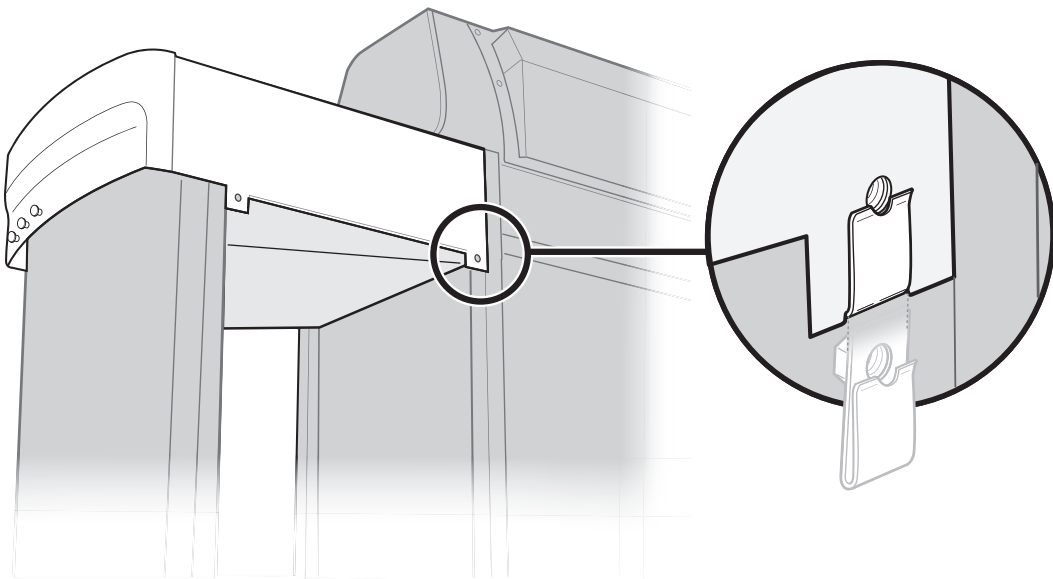
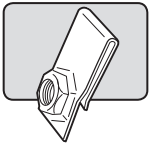

REAR VIEW • VISTA POSTERIOR • VUE DE L'ARRIERE

30

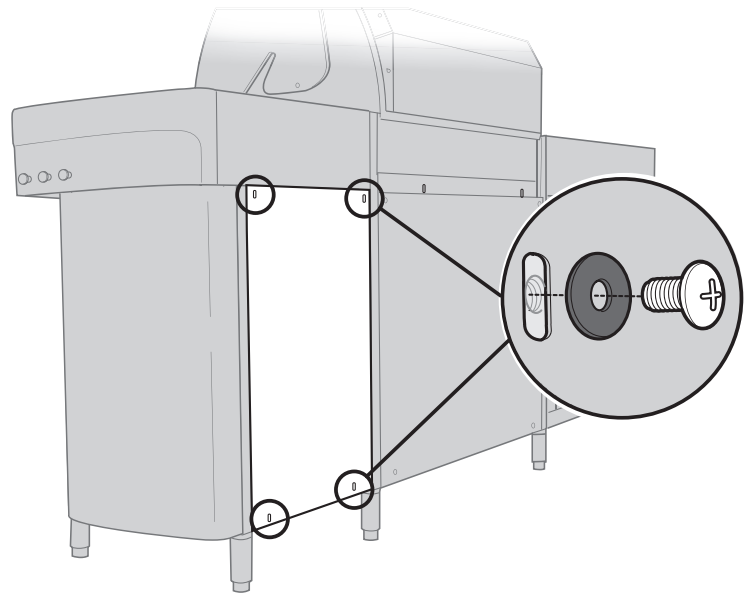
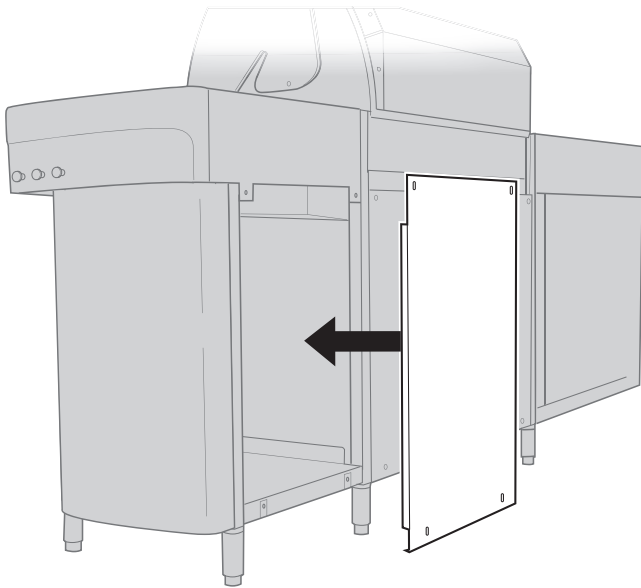
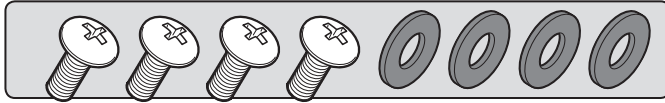

31

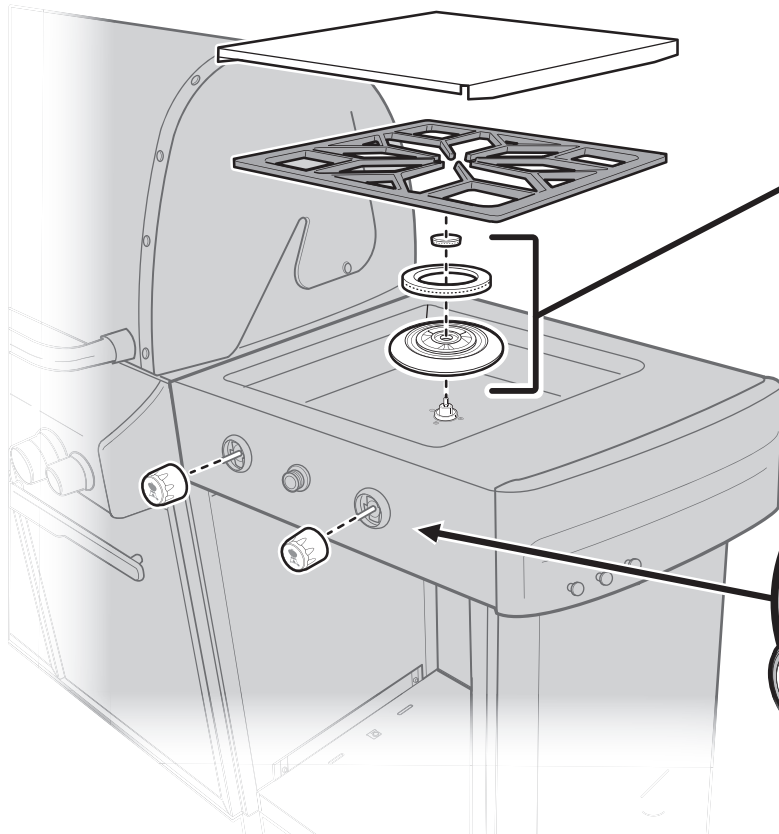

See Owner's Guide for proper installation of Side Burner components.

Para la instalación correcta de los componentes del Quemador Lateral, consulte la Guía del Propietario.

Voir le Mode d'emploi pour l'installation correcte des composants du Brûleur latéral.

32

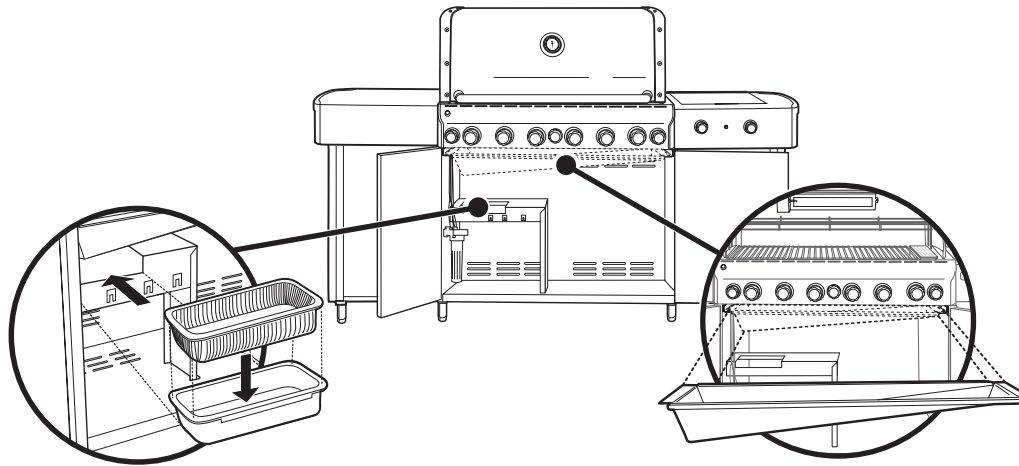

33

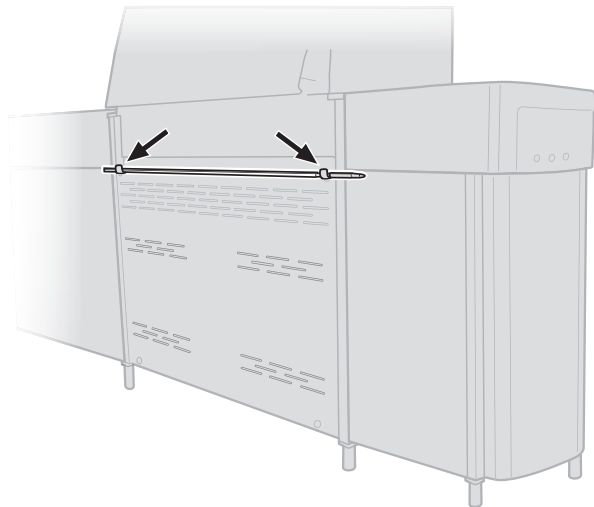
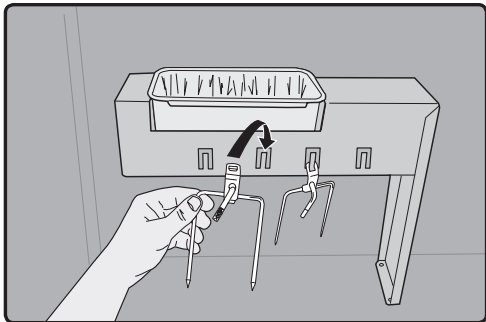
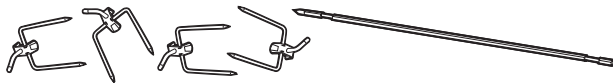

34

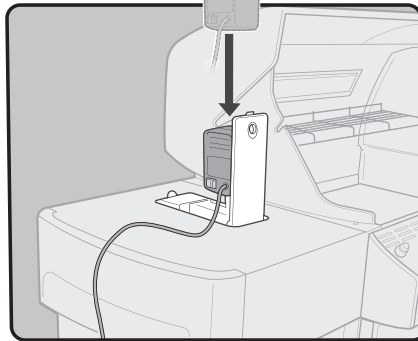
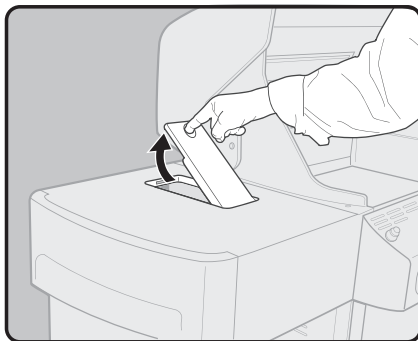

See Owner's Guide for detailed Rotisserie operating and storage instructions.

Consulte la Guía del Propietario para las instrucciones detalladas sobre la operación y almacenaje del Asador Rotativo.

Voir le Mode d'emploi pour des instructions détaillées concernant l'utilisation et le rangement de la Rôtisserie.

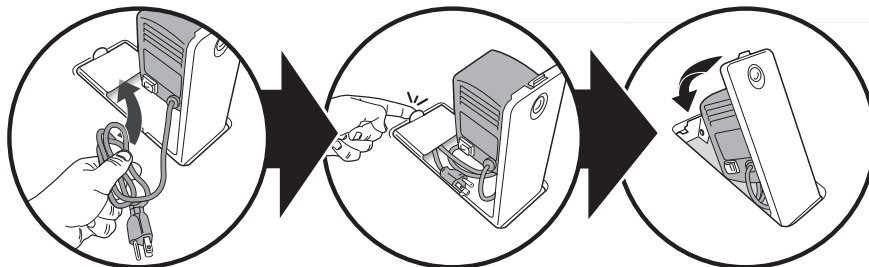

35

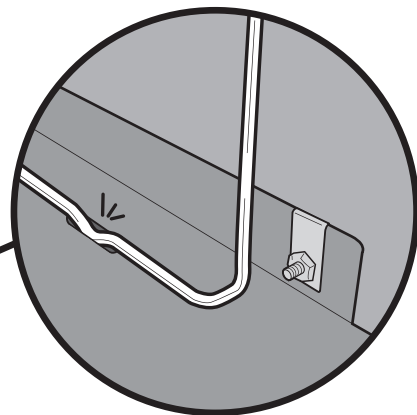
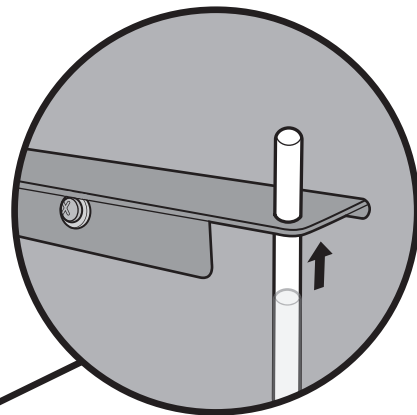
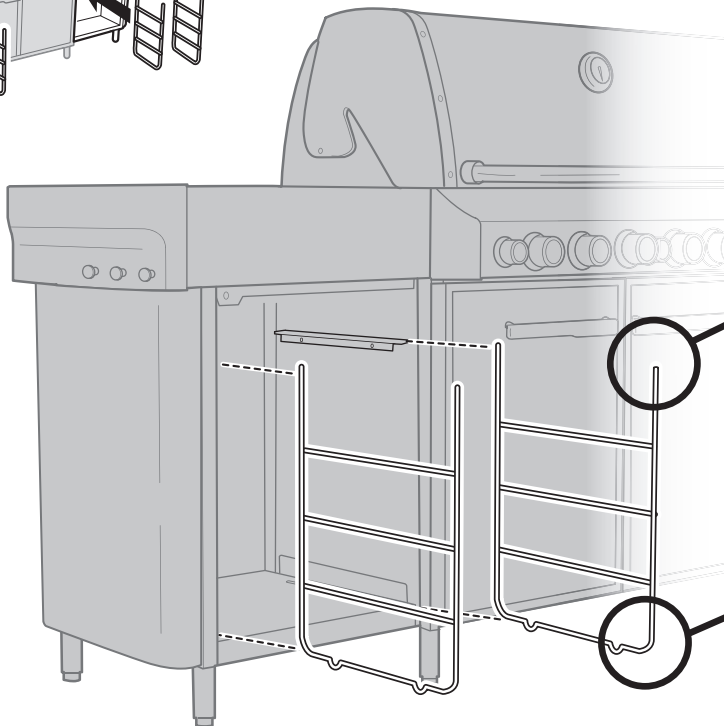
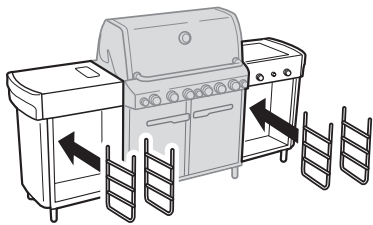

36

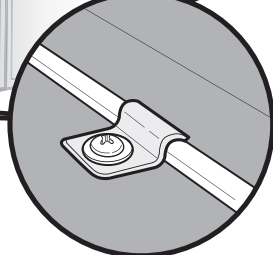
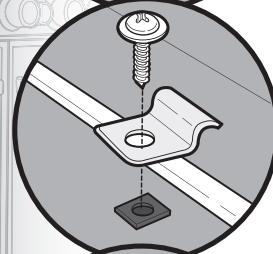
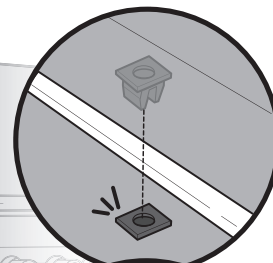
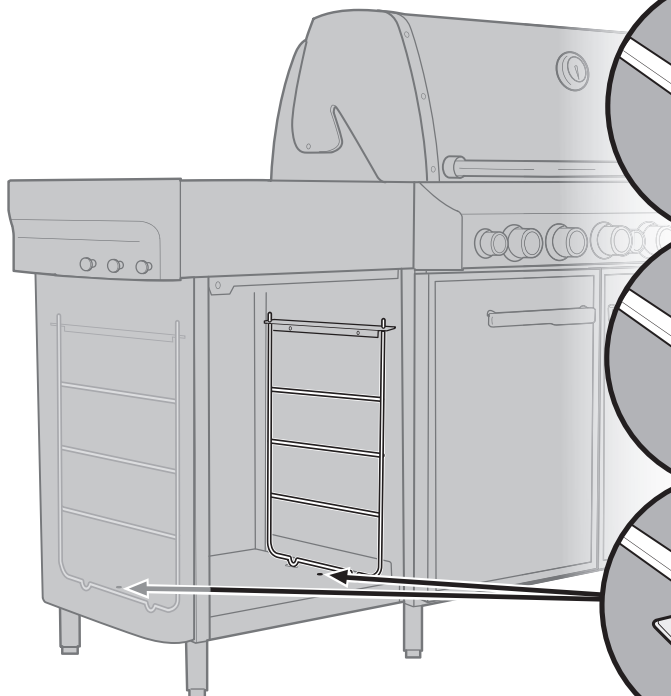
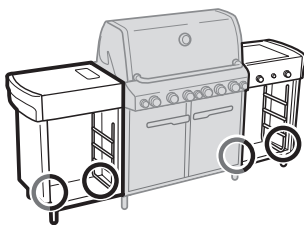
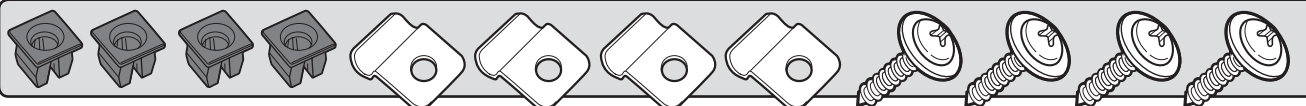

37

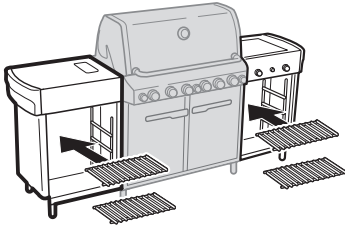

38

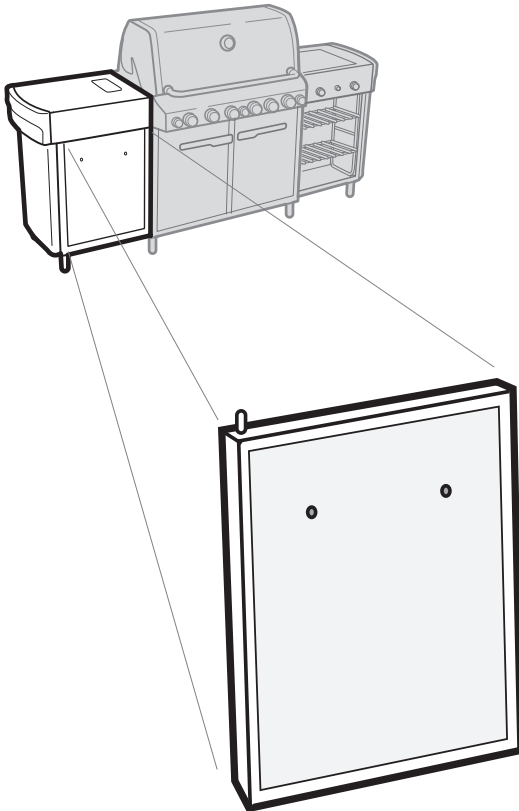

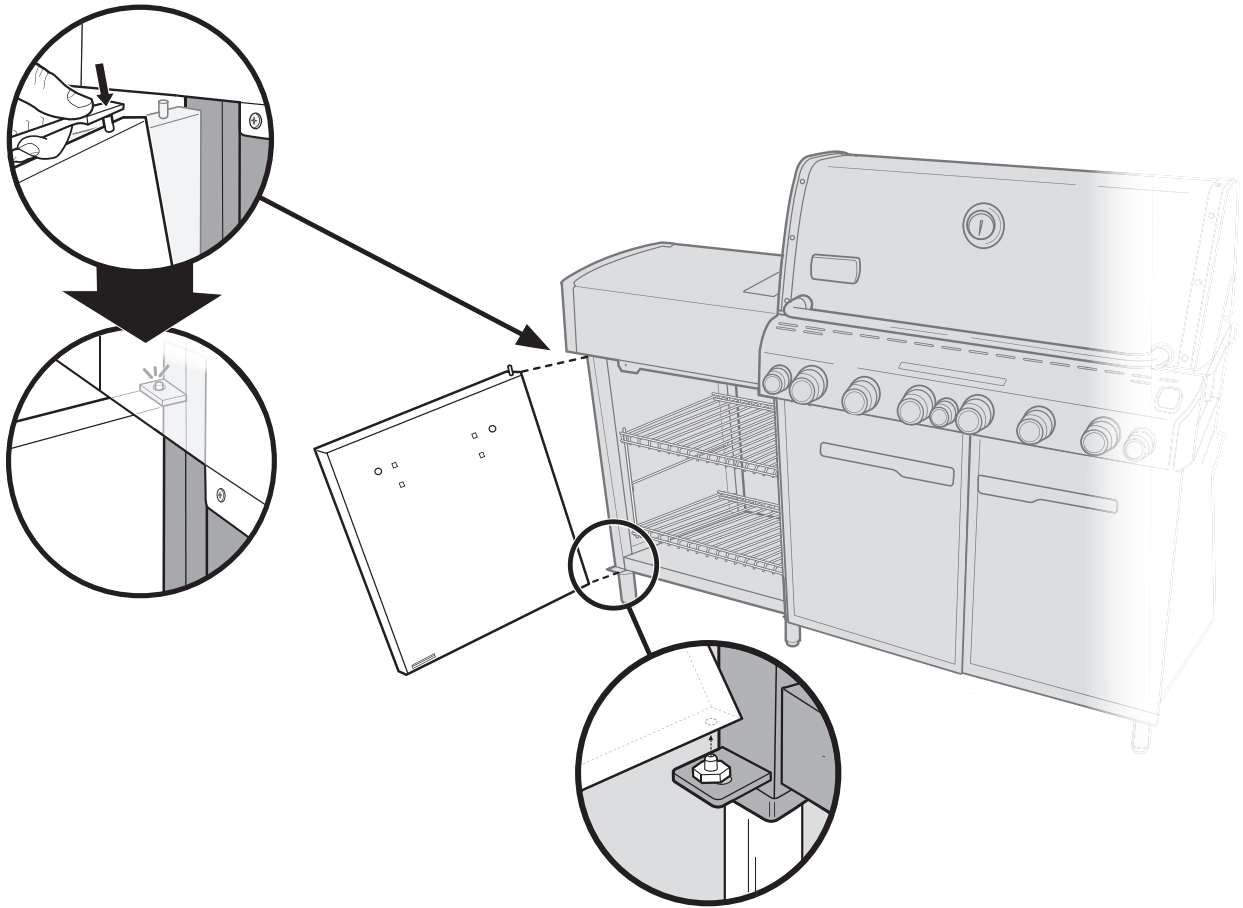

39

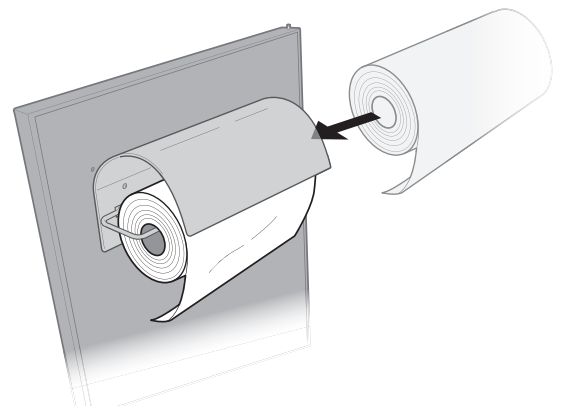
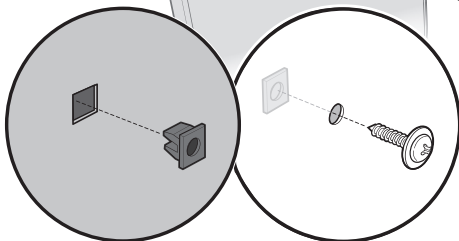
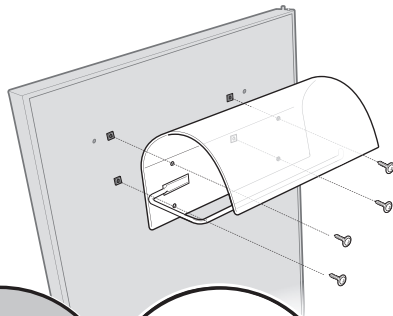
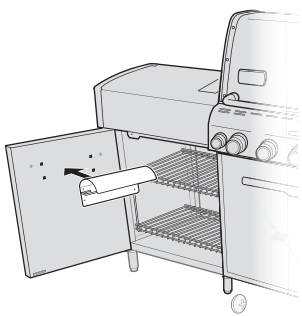
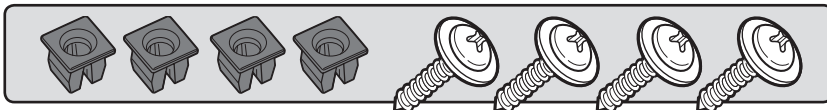

40

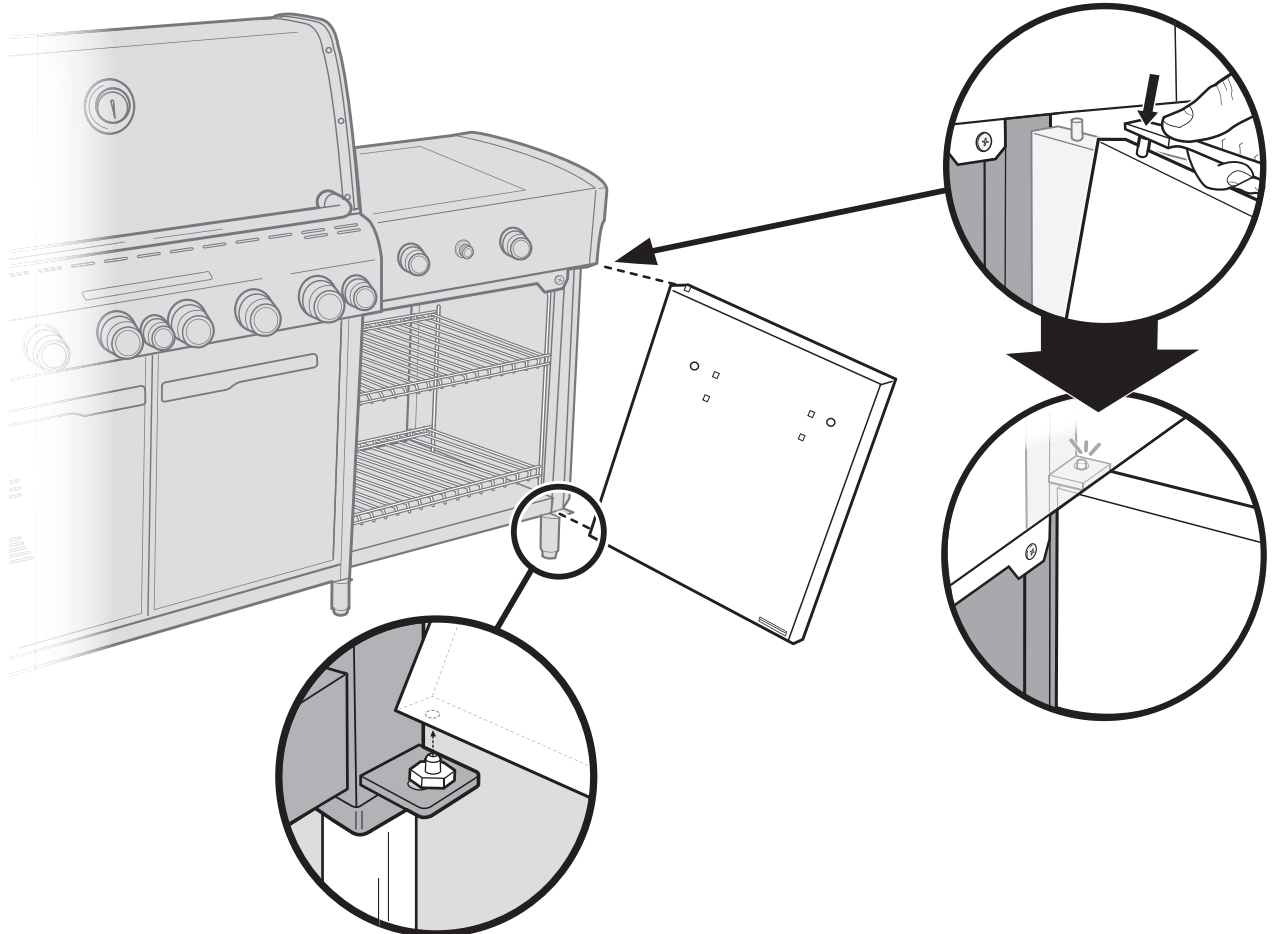
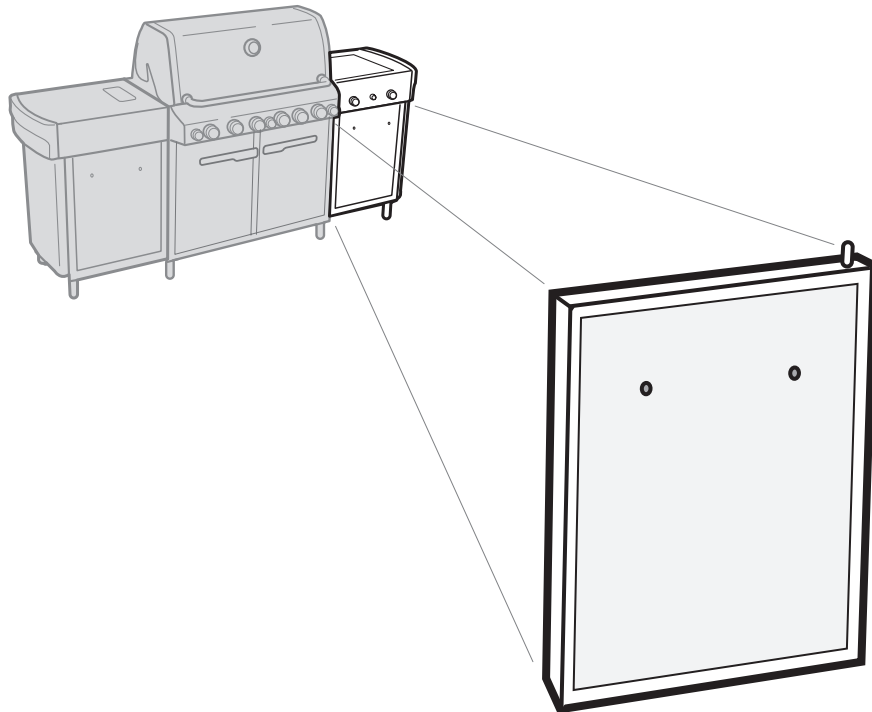

41

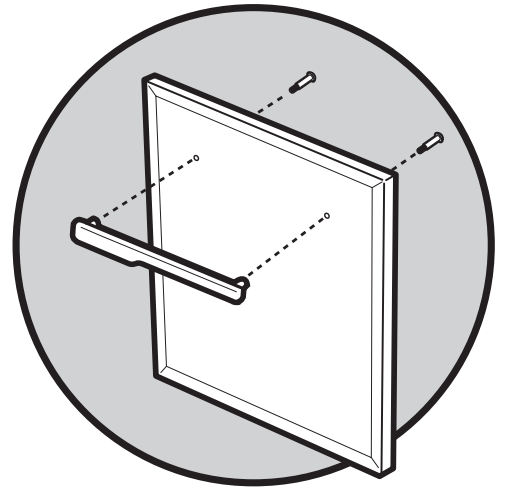
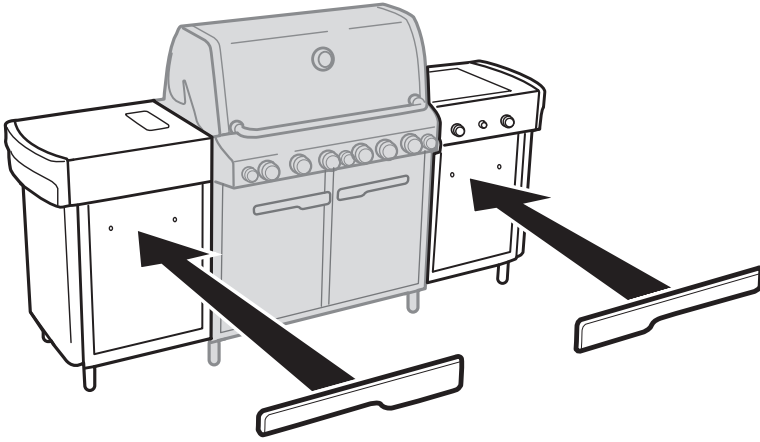
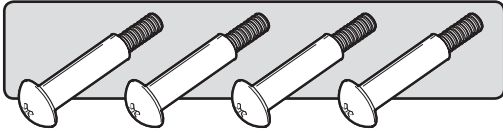

42

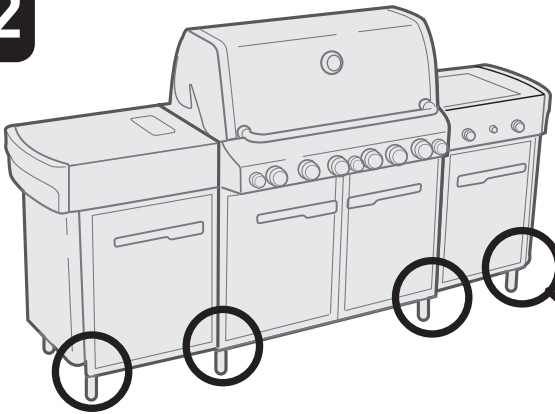

Align doors, if necessary.

Si fuese necesario, alinee las puertas.

Alignez les portes si nécessaire.

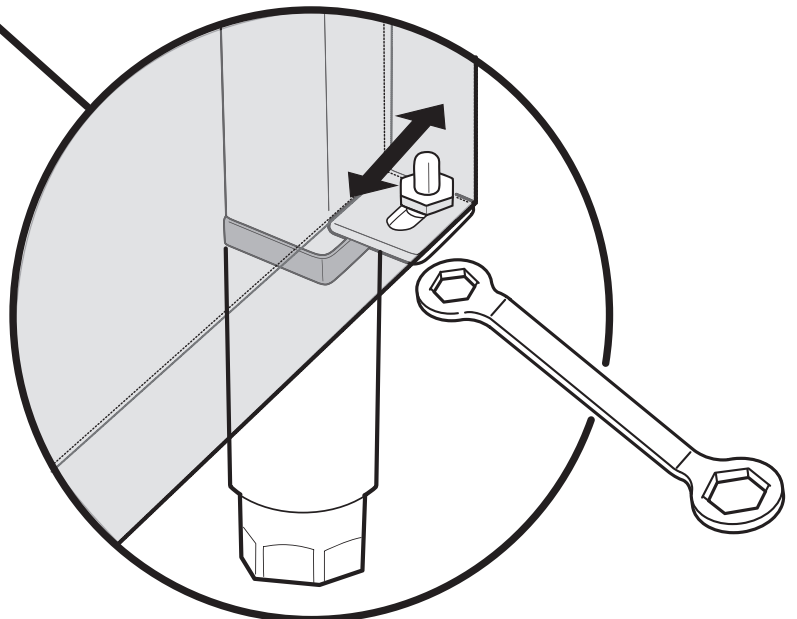

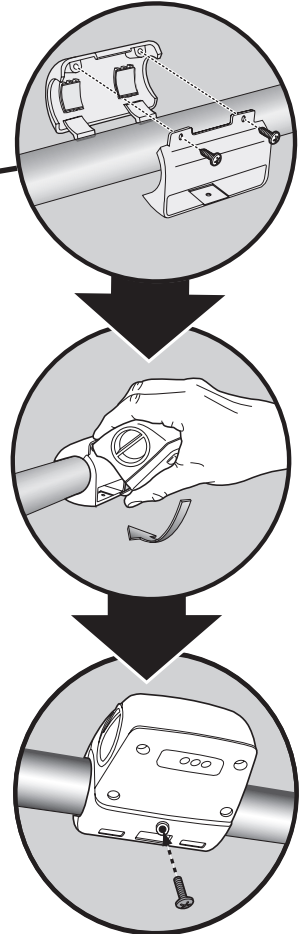
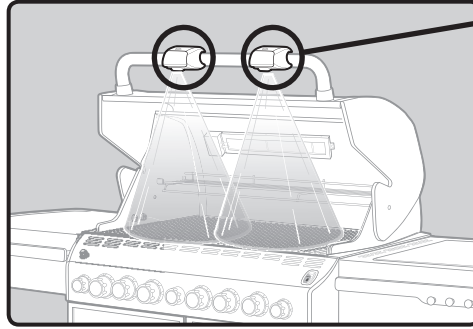
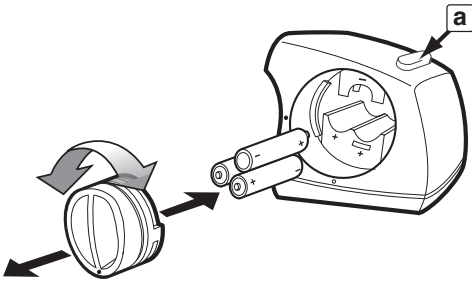
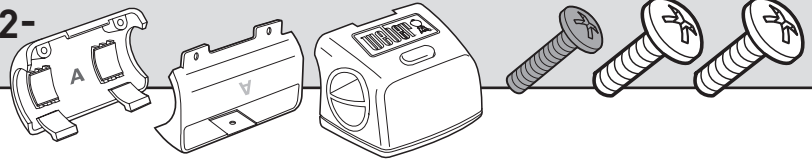
43**2-**

The Weber Grill Out™ Handle Light has a "Tilt Sensor": Lid up - ON / Lid Closed - OFF. The power button **(a)** activates or deactivates the "Tilt Sensor." For daytime use, deactivate the sensor by pressing power button **(a)**.

Requires 3 "AAA" alkaline batteries (not included).

La Lámpara de Asa Weber Grill Out™ cuenta con un "Sensor de Inclinación": Tapa abierta - encendida / Tapa cerrada - apagada. El botón de encendido **(a)** activa o desactiva al "Sensor de Inclinación." Para usarse durante el día, desactive el sensor pulsando el botón de encendido **(a)**.

Requiere 3 pilas alcalinas "AAA" (no están incluidas).

L'éclairage de poignée Weber Grill Out™ est équipé d'un "Détecteur d'inclinaison" : Couvercle ouvert - ALLUME / Couvercle fermé - ETEINT. Le bouton de mise sous tension **(a)** active ou désactive le "Détecteur d'inclinaison". Pour une utilisation pendant la journée, désactivez le capteur en appuyant sur le bouton de mise sous tension **(a)**.

Nécessite 3 piles alcalines "AAA" (non fournies).



⚠ ATTENTION: This product has been safety tested and is only certified for use in a specific country. Refer to country designation located on outer carton.

These parts may be gas carrying or gas burning components. Please contact Weber-Stephen Products LLC, Customer Service Department for genuine Weber-Stephen Products LLC replacement part(s) information.

⚠ WARNING: Do not attempt to make any repair to gas carrying, gas burning, igniter components or structural components without contacting Weber-Stephen Products LLC, Customer Service Department. Your actions, if you fail to follow this Product Warning, may cause a fire, an explosion, or structural failure resulting in serious personal injury or death as well as damage to property.

⚠ ATENCIÓN: A este producto se le han realizado pruebas de seguridad y ha sido certificado para usarse en un país específico. Refiérase al país indicado en la parte externa del cartón de empaque.

Estas partes pueden ser componentes que transporten gas o lo quemem. Por favor póngase en contacto con el Departamento de Atención al Cliente de Weber-Stephen Products LLC para obtener información sobre las partes de repuesto Weber-Stephen Products LLC genuinas.

⚠ ADVERTENCIA: No trate de realizar reparación alguna a los componentes que transporten o quemem gas sin antes ponerse en contacto con el Departamento de Atención al Cliente de Weber-Stephen Products LLC. Si no llegase a acatar esta advertencia, sus acciones podrían causar un fuego o una explosión que resulte en lesiones personales serias o la muerte o daños a la propiedad.

⚠ ATTENTION : Ce produit a fait l'objet de tests de sécurité et est certifié pour une utilisation dans un pays particulier uniquement. Vérifiez la désignation de pays située sur le carton d'emballage.

Ces pièces peuvent contenir du gaz ou être des éléments dont la combustion produit du gaz. Veuillez consulter le Service clientèle de Weber-Stephen Products LLC pour des renseignements sur les pièces de rechange originales de Weber-Stephen Products LLC.

⚠ MISE EN GARDE : Ne tentez pas d'effectuer des réparations sur des éléments contenant du gaz ou sur des éléments dont la combustion produit du gaz sans contacter le service clientèle de Weber-Stephen Products LLC. Si vous ne suivez pas la présente Mise en garde relative au produit, vos actions risquent de provoquer un incendie ou une explosion entraînant des blessures physiques graves voire un décès ainsi que des dégâts matériels.



WEBER-STEPHEN PRODUCTS LLC
www.weber.com®

© 2011 Designed and engineered by Weber-Stephen Products LLC,
a Delaware limited liability company, located at 200 East Daniels Road, Palatine, Illinois 60067 U.S.A.
Printed in U.S.A.

© 2011 Diseñado por Weber-Stephen Products LLC,
una empresa de responsabilidad limitada de Delaware, ubicada en 200 East Daniels Road, Palatine, Illinois 60067 EE.UU.
Impreso en los EE.UU.

© 2011 Elaboré et conçu par Weber-Stephen Products LLC,
société à responsabilité limitée du Delaware, implantée au 200 East Daniels Road, Palatine, Illinois 60067 U.S.A.
Imprimé aux U.S.A.