

SONY



Home Theater Projector



Spider-Man™: Homecoming now available on 4K Ultra HD.™



Seeing is believing

Experience the immersive excitement and the beauty of a true 4K movie in your home

SXRD™

Uncompromising picture quality

Ultimately, it's the quality of any projector's entire optical system that determines just how good those pictures look when they're projected on screen. And there are no compromises with the advanced SXRD (Silicon X-tal Reflective Display) panels inside Sony's 4K Home Cinema projectors. Approved for full-scale theatrical presentation in cinemas, this SXRD panel uses the same technology you'll find in our professional 4K cinema projectors. Unlike ordinary LCD projectors, each of the three separate red, green, and blue panels are reflective rather than transmissive. That means that light inside the projector bounces off each panel, rather than passing through it before reaching the lens. This results in superb 4K images with an excellent native contrast ratio. And it also avoids the undesirable 'screen door' effect that looks like a mesh of fine lines between each separate pixel. The screen door effect is a common issue with LCD panels used in ordinary data/business projectors - but you won't see it with SXRD.

Native 4K Panel
4096 x 2160
(8.8 million pixels)



SXRD

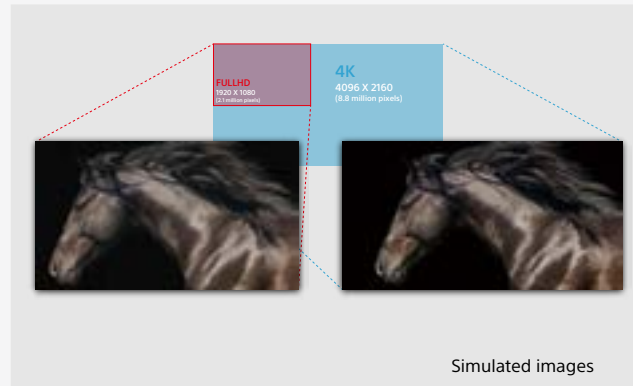

Simulated images

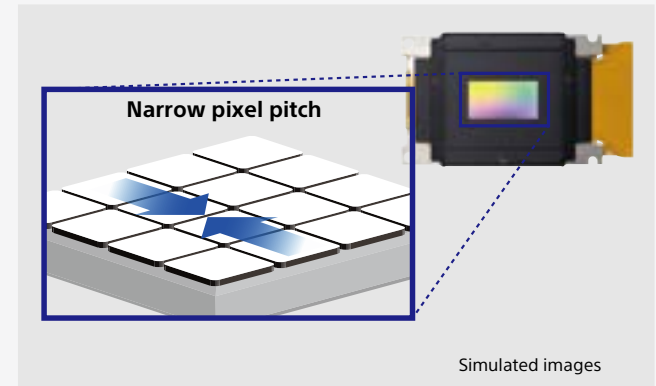

Simulated images

Native 4K

The advanced SXR (Silicon X-tal Reflective Display) panel technology featured in Sony's digital cinema projectors delivers native 4K (4096 x 2160) resolution images, with more than four times the detail of Full HD. Fine details are wonderfully clear and natural, without jagged edges or visible pixels.

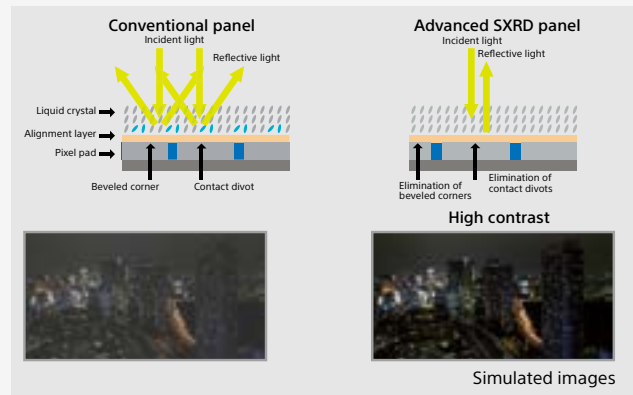

Simulated images

See deeper blacks with 4K SXR Panels

Latest SXR panels deliver even better contrast, as well as native 4K resolution. SXR projection offers rich, inky blacks, as well as clear cinematic motion and image smoothness. Improvements to the silicon layer now mean even better light control, for precisely delivered shadows and blacks.



Color Reproduction

Sony's home theater projector reproduces more tones and textures than a standard projector system. Hard-to-reproduce crimson reds, aqua blues, and emerald greens are displayed beautifully, so landscapes and seascapes look more vivid. Faces look better, too, with skin tones more faithfully reproduced.



VPL-VW5000ES

Laser

4K HDR

5,000 lm

The reference projector for large home cinemas

Spectacular Brightness and Native 4K Clarity

The VPL-VW5000ES brings movies to life with extraordinary cinematic detail, color, and contrast. This reference home cinema projector combines an advanced laser light source with the same Sony 4K SXR panel technology that's found in our professional cinema projectors.

Crisply detailed native 4K images (4096 x 2160) offer four times the resolution of Full HD, pulling you right into the heart of the action with unprecedented clarity. You'll experience rich cinematic colors, smooth motion, and spectacular contrast with extremely powerful brightness, ensuring clear and sharp big-screen pictures, even on the largest home theater screen.



Standard Home Theater Projector



VPL-VW5000ES
Images are brighter and clearer
even in a well-lit environment

Simulated images

Achieved a brightness of 5,000 lumens with the Laser Light Source

The VPL-VW5000ES provides 5,000 lumens by using 4K SXRD panels which have a high utilization efficiency of light from the laser light source. With this amount of light, powerful image expression on large screens and high color purity can be achieved. It can project 4K images full of power and reality.

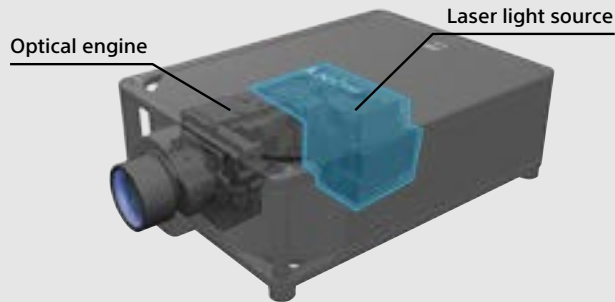

Bright images for years with a Z-Phosphor™ Laser Light

The VPL-VW5000ES's ultra-pure, reliable Sony-developed Z-Phosphor laser light source lets you enjoy perfectly clear 4K pictures with the right brightness level for a very long time. You can also get up to 20,000 hours of uninterrupted operation, with no lamp replacement and virtually zero maintenance.

Analyze every pixel
in any direction

Sony's proprietary algorithm

"Reality Creation"
pixel mapping

Input signal



Get the best possible images



Picture patterning based on 10 years of accumulated expertise

Simulated images

Super-resolution Reality Creation

Exclusive Reality Creation technology analyzes images right down to the pixel level. It uses powerful pattern-matching algorithms developed over years of movie production to enhance image crispness without increasing digital picture noise. It also upscales existing full HD Blu-ray Disc™ and DVD movies to near 4K quality.



VPL-VW995ES

Laser

4K HDR

2,200 lm



VPL-VW885ES

Laser

4K HDR

2,000 lm

Compact, native 4K resolution home projector with laser light source

An ideal choice to fit in your theater room, the VPL-VW995ES/VW885ES bring movies to life with extraordinary cinematic detail, color, and contrast.

This compact size home projector combines an advanced laser light source with the same Sony 4K SXR panel technology that's found in our professional cinema projectors. Crisply detailed native 4K images (4096 x 2160) offer four times the resolution of Full HD, pulling you right into the heart of the action with unprecedented clarity. An ARC-F lens is mounted on the VPL-VW995ES, expressing precise details in every corner of the screen. You'll experience fabulously rich cinematic colors, smooth motion, and spectacular contrast.

Savor the action with 2,200 lumens (VPL-VW995ES) or 2,000 lumens (VPL-VW885ES) brightness and see vibrant images. You're fully prepared with compatibility for the latest 4K standards, including High Frame Rates and HDR (High Dynamic Range) - so you'll get the very best out of today's content, and tomorrow's.

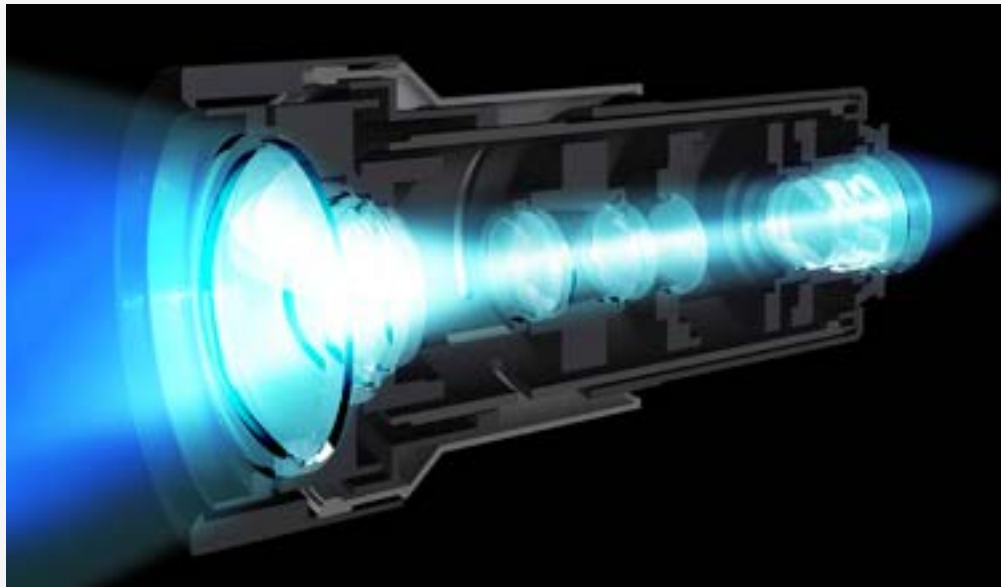

Corner-to-corner sharpness with the ARC-F lens*

For pristine image quality across the entire screen, the VPL-VW995ES features an All-Range Crisp Focus (ARC-F) lens. This large-aperture lens adopts an all-glass design for its 18 elements, including six extra low-dispersion (ELD) elements. This ensures optimal convergence of the red, green, and blue primaries even at the extreme edges of the image for a clear and vivid image wherever you look.

* VPL-VW995ES only

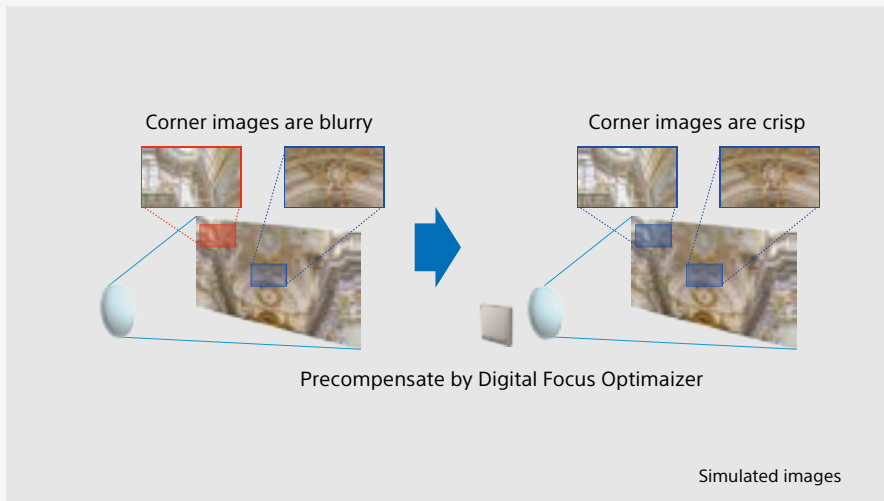

Digital Focus Optimizer*

Optimum focus is achieved, not only optically, but also digitally, by the Digital Focus Optimizer. It compensates in advance from the possible optical degradation of the lens, then outputs the optimum corrected images, so that even the focus in the corners is better than ever.

* VPL-VW995ES only



Dual Contrast Control*

In addition to the dynamically-controlled laser light output, an Advanced Iris is also incorporated. Both the iris control and laser can be adjusted independently, and dynamically, to optimize light output for both dark and bright well-lit scenes. The result is deeper blacks than ever, as well as bright, vibrant colors where needed. The infinite dynamic contrast makes every scene spring to life with detail and realism.

* VPL-VW995ES only



VPL-VW695ES

4K HDR

1,800 lm



VPL-VW295ES

4K HDR

1,500 lm

Bring incredible 4K detail to your favorite movies

Imagine bringing the truly cinematic quality of 4K into your own home. Now you can make this a reality with our VPL-VW695ES/VW295ES series of Home Theater projectors. The VPL-VW695ES/VW295ES produce true 4K resolution images with our native 4K (4096 x 2160) SXRD panels – that’s over four times the quality of Full HD. Designed for your home theater room and living room, the VPL-VW695ES/VW295ES deliver stunning, detail-packed images and incredibly lifelike color as never before. And with 1,800 lumens (VPL-VW695ES) or 1,500 lumens (VPL-VW295ES) high brightness, you’re guaranteed an exceptional picture. The VPL-VW695ES achieves high dynamic contrast using its advanced Iris, and provides Picture Position Memories for true cinema format lovers.

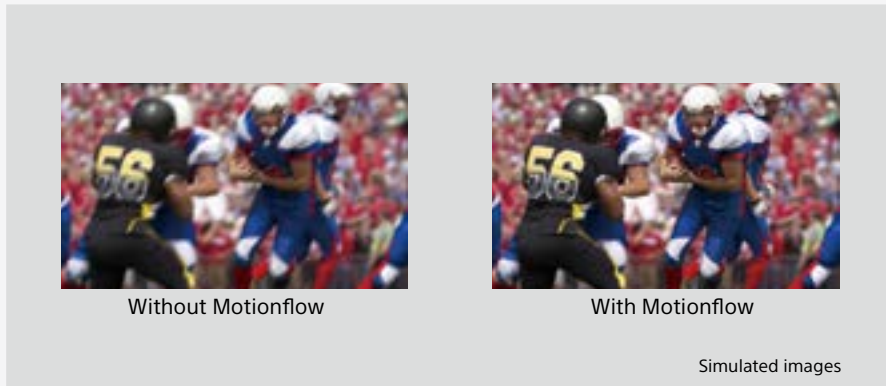

4K Motionflow™

The powerful video processor in the VW695ES/VW295ES offers Motionflow for smooth and clear motion, even when viewing 4K content. Motionflow adds frames to reduce blur, while maintaining brightness, making it ideal for fast-moving sports content. Cinema purists can choose True Theater mode to retain the original 24fps.

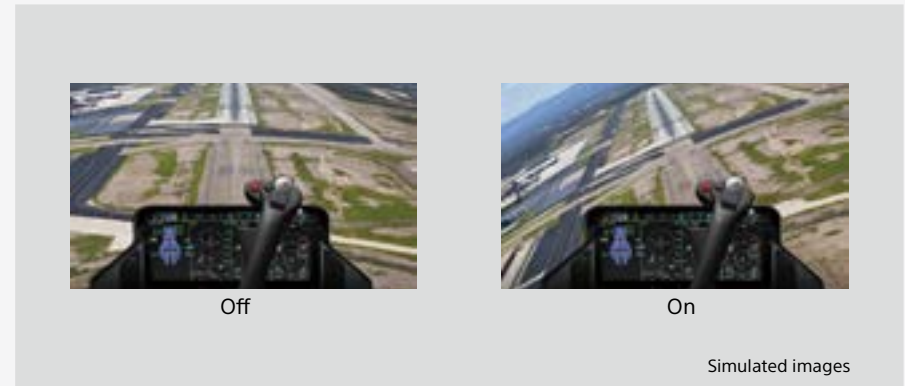

Input Lag Reduction

Input lag reduction mode is installed to enjoy games comfortably. By shortening the video delay caused by image processing, a stress free game experience was achieved. Even for games that require severe timing, the intention of the player can be reflected.

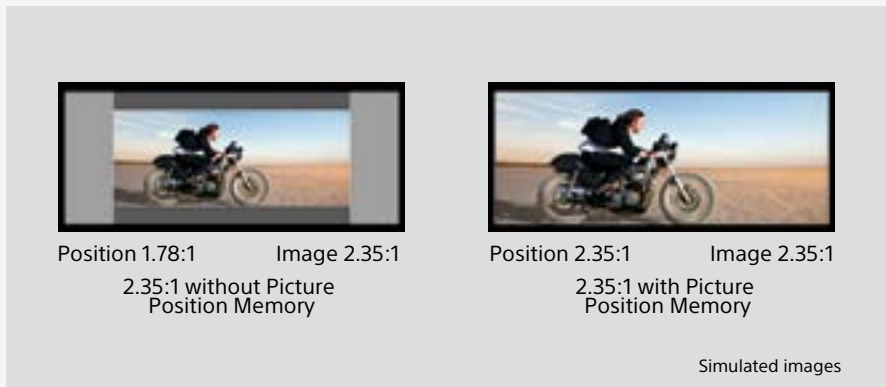

Picture Position Memory*

Picture position memories let you switch between movie and TV aspect ratios, including Cinemascope and 16:9, at the push of a button.

* VPL-VW695ES only

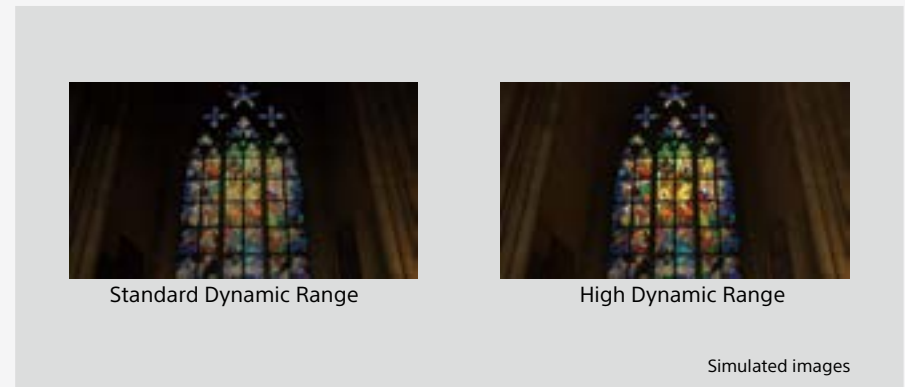

HDR Compatible

Get the most from your projector when viewing new UHD Blu-ray discs and streaming services with High Dynamic Range (HDR). HDR video offers a vastly expanded brightness range to deliver far more realistic, high-contrast images and brilliant colors. Compatible with both HDR10 and HLG (Hybrid Log-Gamma) formats, Sony's home projectors reproduce color and contrast faithfully to the creators' intent.





Ultra short throw 4K home theater projector with a 120" large screen, simply by placing it next to a wall

By adopting the ultra short focus lens, simply by placing it next to a wall or a window, a screen from 80 inches up to 120 inches spreads in front of your eyes.



VPL-VZ1000ES

4K HDR

2,500 lm

Get closer to a real cinema experience

Movies come alive with the VPL-HW65ES/HW45ES full HD 3D Home cinema projectors packed with our latest technology for an incredibly sharp, crystal-clear cinematic experience.



VPL-HW65ES / HW45ES

Full HD

1,800 lm

4K Projectors Line Up

| | | VPL-VW5000ES | VPL-VW995ES | VPL-VW885ES | VPL-VW695ES | VPL-VW295ES | |
|-----------------|-------------------|---|---|---|---|---|---|
| | |  |  |  |  |  | |
| Picture Quality | Brightness | 5,000 lm | 2,200 lm | 2,000 lm | 1,800 lm | 1,500 lm | |
| | Light Source |  |  |  | Lamp | Lamp | |
| | Clarity | Resolution |  |  |  |  |  |
| | | Lens | ARC-F* Lens | ARC-F* Lens | | | |
| | | Engine | Reality Creation | Reality Creation | Reality Creation | Reality Creation | Reality Creation |
| | Color Space |  |  |  |  |  | |
| | Contrast | Contrast | ∞:1 | ∞:1 | ∞:1 | 350,000:1 | |
| | | Dynamic Contrast Control | Dynamic Laser Control | Dynamic Laser Control | Dynamic Laser Control | | |
| | | | Advanced Iris | | Advanced Iris | | Advanced Iris |
| | Motionflow | 4K Motionflow | 4K Motionflow | 4K Motionflow | 4K Motionflow | 4K Motionflow | |
| Ease of Use | Picture Position | Picture Position Memory | Picture Position Memory | Picture Position Memory | Picture Position Memory | Picture Position Memory | |
| | Game | 4K60P Input Lag Reduction | 4K60P Input Lag Reduction | 4K60P Input Lag Reduction | 4K60P Input Lag Reduction | 4K60P Input Lag Reduction | |
| | HDR Compatibility | Format | HDR10/HLG | HDR10/HLG | HDR10/HLG | HDR10/HLG | HDR10/HLG |
| | | Bandwidth | 18 Gbps | 18 Gbps | 18 Gbps | 18 Gbps | 18 Gbps |

* All-Range Crisp Focus

Features

VPL-VW5000ES/VW995ES/VW885ES/VW695ES/VW295ES/VZ1000ES

Native 4K SXRD™ Panel

The advanced SXRD (Silicon X-tal Reflective Display) panel technology featured in Sony's digital cinema projectors delivers native 4K (4096 x 2160) resolution images, with more than four times the detail of Full HD.

Fine details are wonderfully clear and natural, without jagged edges or visible pixels.

VPL-VW5000ES/VW995ES/VW885ES/VW695ES/VW295ES/VZ1000ES

Super-resolution Reality Creation for 4K contents

Exclusive Reality Creation technology analyzes images right down to the pixel level. It uses powerful pattern-matching algorithms developed over years of movie production to enhance image crispness without increasing digital picture noise. It also upscales existing full HD Blu-ray Disc™ and DVD movies to near 4K quality.

VPL-VW5000ES/VW995ES/VW885ES/VW695ES

Picture Position Memory Stores Your Settings

Store focus, zoom, and lens shift settings for up to five screen formats for easy recall. Picture Position Memories store key settings so you can quickly watch movies in the ideal format. Match aspect ratios, including 16:9 and Cinemascope, and store these settings in the projector.

VPL-VW5000ES/VW995ES/VW885ES/VW695ES/VW295ES/VZ1000ES

Input Lag Reduction for Gaming

A new feature for gamers. Experience our fastest ever response time between your controller and the screen for ultimate gaming action.

VPL-VW5000ES/VW995ES/VW885ES/VZ1000ES

Watch bright images for longer with a Z-Phosphor™ Laser Light

The projector uses an ultra-pure and reliable Z-Phosphor laser light source. This Sony developed light source offers bright images for up to 20,000 hours of uninterrupted operation - no lamp replacement, and virtually zero maintenance.

VPL-VW5000ES/VW995ES/VW885ES/VW695ES/VW295ES/VZ1000ES

HDMI 18 Gbps Compatibility

With 4K HDR 60P contents increasing, the projector is HDMI 18 Gbps compatible for smoother expressions of image gradations.

VPL-VW5000ES/VW995ES/VW885ES/VW695ES/VW295ES/VZ1000ES

HDR Compatibility: every image comes to life

Get the most from today's UHD Blu-ray discs and streaming services with High Dynamic Range. HDR video offers an expanded brightness range that delivers more realistic, high-contrast images and brilliant color. Compatible with both HDR10 and HLG (Hybrid Log-Gamma) formats, Sony's home cinema projectors reproduce color and contrast that's faithful to the creators' intent.

VPL-VW5000ES/VW995ES/VW885ES/VW695ES/VW295ES/VZ1000ES

4K Motionflow™

The powerful video processor in the projector offers Motionflow for smooth and clear motion, even when viewing 4K content. Motionflow adds frames to reduce blur, while maintaining brightness, making it ideal for fast-moving sports content. Cinema purists can choose True Theater mode to retain the original 24fps.

VPL-VW5000ES/VW995ES/VW885ES/VW695ES/VZ1000ES

Built-in Auto Calibration

After extended periods, color can be automatically calibrated to the original factory condition. There's no need for extra calibration equipment or cameras; a built-in color sensor stores all the necessary information.

VPL-VW5000ES/VPL-VW995ES/VW885ES/VW695ES/HW65ES

Remarkable Dynamic Contrast for Highest Picture Quality

Adjusted by Iris for VPL-VW695ES and VPL-HW65ES.

Adjusted by laser control for VPL-VW5000ES and VPL-VW885ES.

Adjusted by both laser and Iris for VPL-VW995ES.

VPL-VW5000ES/VW995ES/VW885ES/VW695ES/VW295ES/VZ1000ES

Motorised Zoom Lens and Wide Lens Shift

Installing this projector in your room is easy with a motorised zoom with a wide lens shift range. Adjust the position of the projector vertically and horizontally to get just the right angle for your movies.

SPECIFICATIONS

| | | VPL-VW5000ES | VPL-VW995ES | VPL-VW885ES | VPL- VW695ES |
|---|--|--|--|--|---|
| Display system | | 4K SXRD panel, projection system | 4K SXRD panel, projection system | 4K SXRD panel, projection system | 4K SXRD panel, projection system |
| Display device | Size of effective display area | 0.74" x 3 | 0.74" x 3 | 0.74" x 3 | 0.74" x 3 |
| | Number of pixels | 26,542,080 (4096 x 2160 x 3) pixels | 26,542,080 (4096 x 2160 x 3) pixels | 26,542,080 (4096 x 2160 x 3) pixels | 26,542,080 (4096 x 2160 x 3) pixels |
| Projection lens | Focus | Powered | Powered | Powered | Powered |
| | Zoom | Powered | Powered | Powered (Approx. x 2.06) | Powered (Approx. x 2.06) |
| | Lens shift | VPLL-Z7013 (Bundled) : Powered, Vertical: +/-80 %, Horizontal: +/-31 % | VPLL-Z7013 (Bundled) : Powered, Vertical: +/-80 %, Horizontal: +/-31 % | Powered, Vertical: +85 % -80 %, Horizontal: +/-31 % | Powered, Vertical: +85 % -80 %, Horizontal: +/-31 % |
| | | VPLL-Z7008 (Optional) : Powered, Vertical: +/-50 %, Horizontal: +/-18 % | VPLL-Z7008 (Optional) : Powered, Vertical: +/-50 %, Horizontal: +/-18 % | - | - |
| Throw ratio ^{*1} | VPLL-Z7013 (Bundled) : 1.35 : 1 to 2.90 : 1 | VPLL-Z7013 (Bundled) : 1.35 : 1 to 2.90 : 1 | 1.38 : 1 to 2.83 : 1 | 1.38 : 1 to 2.83 : 1 | |
| | VPLL-Z7008 (Optional) : 0.85 : 1 to 1.06 : 1 | VPLL-Z7008 (Optional) : 0.85 : 1 to 1.06 : 1 | - | - | |
| Light source | Laser diode | Laser diode | Laser diode | High-pressure mercury lamp, 280 W type | |
| Recommended lamp replacement time ^{*2} | - | - | - | 6000 H (Lamp mode: Low) | |
| Light output ^{*3} | 5,000 lm | 2,200 lm | 2,000 lm | 1800 lm (Lamp mode: High) | |
| Dynamic contrast | ∞ : 1 | ∞ : 1 | ∞ : 1 | 350,000 : 1 | |
| Accepted digital signals ^{*4} | 480/60p, 576/50p, 720/60p, 720/50p, 1080/60i, 1080/50i, 1080/60p, 1080/50p, 1080/24p, 3840 x 2160/24p, 3840 x 2160/25p, 3840 x 2160/30p, 3840 x 2160/50p, 3840 x 2160/60p, 4096 x 2160/24p, 4096 x 2160/25p, 4096 x 2160/30p, 4096 x 2160/50p, 4096 x 2160/60p | 480/60p, 576/50p, 720/60p, 720/50p, 1080/60i, 1080/50i, 1080/60p, 1080/50p, 1080/24p, 3840 x 2160/24p, 3840 x 2160/25p, 3840 x 2160/30p, 3840 x 2160/50p, 3840 x 2160/60p, 4096 x 2160/24p, 4096 x 2160/25p, 4096 x 2160/30p, 4096 x 2160/50p, 4096 x 2160/60p | 480/60p, 576/50p, 720/60p, 720/50p, 1080/60i, 1080/50i, 1080/60p, 1080/50p, 1080/24p, 3840 x 2160/24p, 3840 x 2160/25p, 3840 x 2160/30p, 3840 x 2160/50p, 3840 x 2160/60p, 4096 x 2160/24p, 4096 x 2160/25p, 4096 x 2160/30p, 4096 x 2160/50p, 4096 x 2160/60p | 480/60p, 576/50p, 720/60p, 720/50p, 1080/60i, 1080/50i, 1080/60p, 1080/50p, 1080/24p, 3840 x 2160/24p, 3840 x 2160/25p, 3840 x 2160/30p, 3840 x 2160/50p, 3840 x 2160/60p, 4096 x 2160/24p, 4096 x 2160/25p, 4096 x 2160/30p, 4096 x 2160/50p, 4096 x 2160/60p | |
| Input Output (Computer / Video / Control) | HDMI | x 2 (18 Gbps, HDCP2.2) | x 2 (18 Gbps, HDCP2.2) | x 2 (18 Gbps, HDCP2.2) | x 2 (18 Gbps, HDCP2.2) |
| | Trigger | x 2 (Mini jack, DC 12 V, Max. 100 mA) | x 2 (Mini jack, DC 12 V, Max. 100 mA) | x 2 (Mini jack, DC 12 V, Max. 100 mA) | x 2 (Mini jack, DC 12 V, Max. 100 mA) |
| | RS-232C | D-sub 9-pin (female) | D-sub 9-pin (female) | D-sub 9-pin (male) | D-sub 9-pin (male) |
| | LAN | RJ-45, 10BASE-T/100BASE-TX | RJ-45, 10BASE-T/100BASE-TX | RJ-45, 10BASE-T/100BASE-TX | RJ-45, 10BASE-T/100BASE-TX |
| | IR IN / OUT | IN: x 1, Out: x 1 (Mini jack) | IN: x 1 (Mini jack) | IN: x 1 (Mini jack) | IN: x 1 (Mini jack) |
| USB | x 1 (Type A, DC 5 V, Max. 500 mA) | x 1 (Type A, DC 5 V, Max. 500 mA) | x 1 (Type A, DC 5 V, Max. 500 mA) | x 1 (Type A, DC 5 V, Max. 500 mA) | |
| Reality creation | Yes (4K/2K) | Yes (4K/2K) | Yes (4K/2K) | Yes (4K/2K) | |
| Digital focus optimizer | - | Yes | - | - | |
| Dynamic contrast control | Laser light control | Laser light control and Advanced Iris | Laser light control | Advanced Iris | |
| Motionflow | Yes (4K/2K) | Yes (4K/2K) | Yes (4K/2K) | Yes (4K/2K) | |
| HDR | HDR/HLG | HDR/HLG | HDR/HLG | HDR/HLG | |
| 3D | Yes | Yes | Yes | Yes | |
| Picture position memory | 5 | 5 | 5 | 5 | |
| Input lag reduction | Yes (4K/2K) | Yes (4K/2K) | Yes (4K/2K) | Yes (4K/2K) | |
| Acoustic noise ^{*5} | 30 dB | 24 dB | 24 dB | 26 dB | |
| Power requirements | AC 100 V - 240 V, 50/60 Hz | AC 100-240 V, 50/60 Hz | AC 100-240 V, 50/60 Hz | AC 100-240 V, 50/60 Hz | |
| Power consumption | 1.2 kW | 490 W | 430 W | 460 W | |
| | Standby | 0.4 W (when "Remote Start" is set to "Off") | 0.4 W (when "Remote Start" is set to "Off") | 0.4 W (when "Remote Start" is set to "Off") | 0.4 W (when "Remote Start" is set to "Off") |
| | Networked Standby | 1.0 W (LAN) (when "Remote Start" is set to "On") | 1.0 W (LAN) (when "Remote Start" is set to "On") | 1.0 W (LAN) (when "Remote Start" is set to "On") | |
| Dimensions (Without Protrusions) | W 550 x H 228 x D 750 mm (W 21 21/32 x H 8 31/32 x D 29 17/32 in) | W 560 x H 223 x D 496 mm (W 22 1/16 x H 8 25/32 x D 19 17/32 in) | W 560 x H 223 x D 496 mm (W 22 1/16 x H 8 25/32 x D 19 17/32 in) | W 496 x H 205 x D 464 mm (W 19 1/2 x H 8 3/32 x D 18 1/4 in) | |
| Mass | Approx. 43 kg / 95 lb | Approx. 22 kg / 49 lb | Approx. 20 kg / 44 lb | Approx. 14 kg / 31 lb | |
| Supplied accessories | RM-PJ24 Remote Commander (1), Size AA (R6) Nanganese Batteries (2), AC power Cord (1), Lens Cap (1), Plug holder (1), Operating Instructions (CD-ROM) (1), Quick Reference Manual (1), Safety Regulations (1) | RM-PJ24 Remote Commander (1), Size AA (R6) Manganese Batteries (2), AC Power Cord (1), Lens Cap (1), Operating Instructions (CD-ROM) (1), Quick Reference Manual (1), Safety Regulations (1) | RM-PJ24 Remote Commander (1), Size AA (R6) Manganese Batteries (2), AC Power Cord (1), Lens Cap (1), Operating Instructions (CD-ROM) (1), Quick Reference Manual (1), Safety Regulations (1) | RM-PJ24 Remote Commander (1), Size AA (R6) Manganese Batteries (2), AC Power Cord (1), Lens Cap (1), Operating Instructions (CD-ROM) (1), Quick Reference Manual (1), Safety Regulations (1) | |
| Optional accessories | VPLL-Z7008 (Short throw lens), TDG-BT500A (3D glass) | VPLL-Z7008 (Short throw lens), TDG-BT500A (3D glass) | TDG-BT500A (3D glass) | LMP-H280 (Lamp), TDG-BT500A (3D glass) | |

*1 Display size : 16:9 *2 The figures are expected maintenance time and not guaranteed. They will depend on the environment or how the projector is used.

*3 This value is estimated. *4 60p, 30p, 24p include 59.94/60Hz, 29.97Hz/30Hz, 23.98Hz/24Hz *5 They will depend on the environment or how the projectors is used.

| | | VPL-VW295ES | VPL-VZ1000ES | VPL-HW65ES | VPL-HW45ES |
|--|-----------------------------------|--|--|--|---|
| Display system | | 4K SXRD panel, projection system | 4K SXRD panel, projection system | SXRD panel, projection system | SXRD panel, projection system |
| Display device | Size of effective display area | 0.74" x 3 | 0.74" x 3 | 0.61" x 3 | 0.61" x 3 |
| | Number of pixels | 26,542,080 (4096 x 2160 x 3) pixels | 26,542,080 (4096 x 2160 x 3) pixels | 6,220,800 (1920 x 1080 x 3) pixels | 6,220,800 (1920 x 1080 x 3) pixels |
| Projection lens | Focus | Powered | Powered | Manual | Manual |
| | Zoom | Powered (Approx. x 2.06) | Powered (Approx. x1.02) | Manual (Approx. x1.6) | Manual (Approx. x1.6) |
| | Lens shift | Powered, Vertical: +85 % -80 % Horizontal: +/-31 % | Powered, Vertical: +/- 6%, Horizontal: +/-3% | Manual, Vertical: +/- 71%, Horizontal: +/- 25% | Manual, Vertical: +/- 71%, Horizontal: +/- 25% |
| | Throw ratio*1 | 1.38 : 1 to 2.83 : 1 | - | 1.36 : 1 to 2.16 : 1 | 1.36 : 1 to 2.16 : 1 |
| Light source | | High-pressure mercury lamp, 225 W type | Laser diode | High-pressure mercury lamp, 215 W type | High-pressure mercury lamp, 215 W type |
| Recommended lamp replacement time*2 | | 6000 H (Lamp mode: Low) | - | 6000 H (Lamp mode: Low) | 6000 H (Lamp mode: Low) |
| Light output*3 | | 1500 lm (Lamp mode: High) | 2500 lm | 1800 lm (Lamp mode: High) | 1800 lm (Lamp mode: High) |
| Dynamic contrast | | - | ∞ : 1 | 120,000 : 1 | - |
| Accepted digital signals*4 | | 480/60p, 576/50p, 720/60p, 720/50p, 1080/60i, 1080/50i, 1080/60p, 1080/50p, 1080/24p, 3840 x 2160/24p, 3840 x 2160/25p, 3840 x 2160/30p, 3840 x 2160/50p, 3840 x 2160/60p, 4096 x 2160/24p, 4096 x 2160/25p, 4096 x 2160/30p, 4096 x 2160/50p, 4096 x 2160/60p | 480/60p, 576/50p, 720/60p, 720/50p, 1080/60i, 1080/50i, 1080/60p, 1080/50p, 1080/24p, 3840 x 2160/24p, 3840 x 2160/25p, 3840 x 2160/30p, 3840 x 2160/50p, 3840 x 2160/60p, 4096 x 2160/24p, 4096 x 2160/25p, 4096 x 2160/30p, 4096 x 2160/50p, 4096 x 2160/60p | 480/60p, 576/50p, 720/60p, 720/50p, 1080/60i, 1080/50i, 1080/60p, 1080/50p, 1080/24p | 480/60p, 576/50p, 720/60p, 720/50p, 1080/60i, 1080/50i, 1080/60p, 1080/50p, 1080/24p |
| Input Output (Computer / Video / Control) | HDMI | x 2 (18 Gbps, HDCP2.2) | x 4 (18 Gbps, HDCP2.2) | x 2 | x 2 |
| | Trigger | x 1 (Mini jack, DC 12 V, Max. 100 mA) | x 1 (Mini jack, DC 12 V, Max. 100 mA) | x 1 (Mini jack, DC 12 V, Max. 100 mA) | - |
| | RS-232C | D-sub 9-pin (male) | D-sub 9-pin (female) | D-sub 9-pin (female) | D-sub 9-pin (female) |
| | LAN | RJ-45, 10BASE-T/100BASE-TX | RJ-45, 10BASE-T/100BASE-TX | RJ-45, 10BASE-T/100BASE-TX | - |
| | IR IN / OUT | IN: x 1 (Mini jack) | IN: x 1 (Mini jack) | IN: x 1 (Mini jack) | IN: x 1 (Mini jack) |
| USB | x 1 (Type A, DC 5 V, Max. 500 mA) | x 1 (Type A, DC 5 V, Max. 500 mA) | x 1 (Type A, DC 5 V, Max. 500 mA) | x 1 (Type A, DC 5 V, Max. 500 mA) | |
| Reality creation | | Yes (4K/2K) | Yes (4K/2K) | Yes (2K) | Yes (2K) |
| Digital focus optimizer | | - | - | - | - |
| Dynamic contrast control | | - | Laser light control | Advanced Iris | - |
| Motionflow | | Yes (4K/2K) | Yes (4K/2K) | Yes (2K) | Yes (2K) |
| HDR | | HDR/HLG | HDR/HLG | - | - |
| 3D | | Yes | Yes | Yes | Yes |
| Picture position memory | | - | - | - | - |
| Input lag reduction | | Yes (4K/2K) | Yes (4K/2K) | Yes (2K) | Yes (2K) |
| Acoustic noise*5 | | 26 dB | 24 dB | 22 dB | 22 dB |
| Power requirements | | AC100-240V 50/60 Hz | AC100-240V 50/60 Hz | AC100-240V 50/60 Hz | AC100-240V 50/60 Hz |
| Power consumption | | 390 W | 435 W | 310 W | 310 W |
| | Standby | 0.4 W (when "Remote Start" is set to "Off") | 0.5 W (when "Remote Start" is set to "Off") | 0.4 W (when "Remote Start" is set to "Off") | 0.4 W (when "Remote Start" is set to "Off") |
| | Networked Standby | 1.0 W (LAN) (when "Remote Start" is set to "On") | 0.6 W (LAN) (when "Remote Start" is set to "On") | 1.0 W (LAN) (when "Remote Start" is set to "On") | - |
| Dimensions (Without Protrusions) | | W 496 x H 205 x D 464 mm (W 19 1/2 x H 8 3/32 x D 18 1/4 in) | W 925 mm x H 218.5 mm x D 493.8 mm (W 36 13/32 x H 8 19/32 x D 19 7/16 in) (with side covers) | W 407.4 x H 179.2 x D 463.9 mm (W 16 1/8 x H 7 1/8 x D 18 3/8 in) | W 407.4 x H 179.2 x D 463.9 mm (W 16 1/8 x H 7 1/8 x D 18 3/8 in) |
| Mass | | Approx. 14 kg / 31 lb | Approx. 35 kg / 77 lb | Approx. 9 kg / 20 lb | Approx. 9 kg / 20 lb |
| Supplied accessories | | RM-PJ28 Remote Commander (1), Size AA (R6) Manganese Batteries (2), AC Power Cord (1), Lens Cap (1), Operating Instructions (CD-ROM) (1), Quick Reference Manual (1), Safety Regulations (1) | RM-PJ28 Remote Commander (1), Size AA (R6) Manganese Batteries (2), AC power Cord (1), Plug holder (1), Top cover (1), Side covers (2), Straps for side covers (2), Rivets for side covers (2), Cleaning cloth (1), Operating Instructions (CD-ROM) (1), Quick Reference Manual (this manual) (1), Safety Regulations (1) | RM-PJ28 Remote Commander (1), Size AA (R6) Manganese Batteries (2), AC Power Cord (1), Lens Cap (1), Operating Instructions (CD-ROM) (1), Quick Reference Manual (1) Safety Regulations (1) | RM-PJ28 Remote Commander (1), Size AA (R6) Manganese Batteries (2), AC Power Cord (1), Lens Cap (1), Operating Instructions (CD-ROM) (1), Quick Reference Manual (1), Safety Regulations (1) |
| Optional accessories | | LMP-H220 (Lamp), TDG-BT500A (3D glass) | TDG-BT500A (3D glass) | LMP-H210 (Lamp), TDG-BT500A (3D glass) | LMP-H210 (Lamp), TDG-BT500A (3D glass) |

*1 Display size : 16:9 *2 The figures are expected maintenance time and not guaranteed. They will depend on the environment or how the projector is used. *3 This value is estimated.

*4 60p,30p,24p include 59.94/60Hz, 29.97Hz/30Hz, 23.98Hz/24Hz *5 They will depend on the environment or how the projectors is used.

Dimensions

VPL-VW5000ES

CONNECTOR PANELS

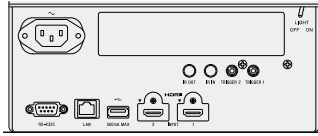

Front

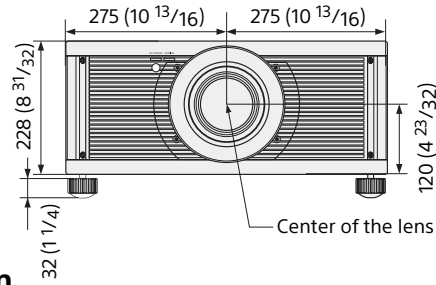

Bottom

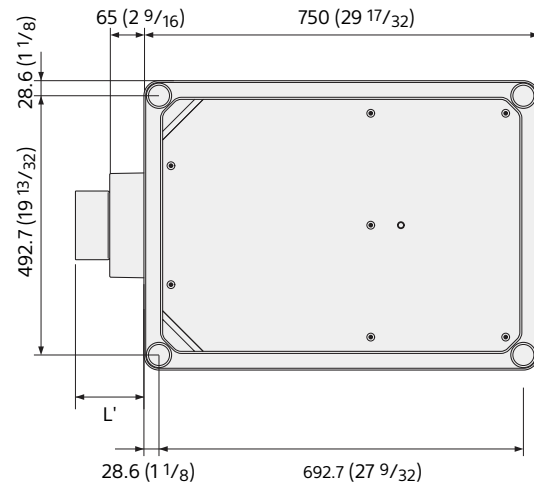

VPLL-Z7013 (Bundled) : L' = 130.2 (5 1/8)
 VPLL-Z7008 (Optional) : L' = Tele 159.0 (6 1/4) / Wide 185.2 (7 9/32)

VPL-VW995ES/VPL-VW885ES

CONNECTOR PANELS

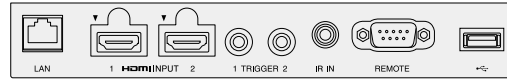

Front

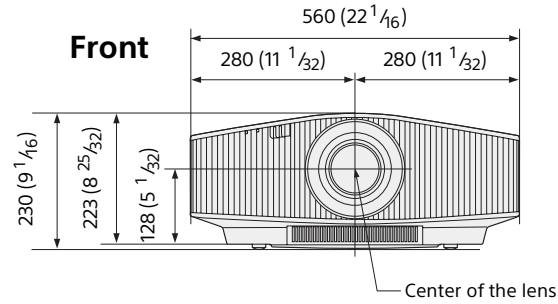

Bottom

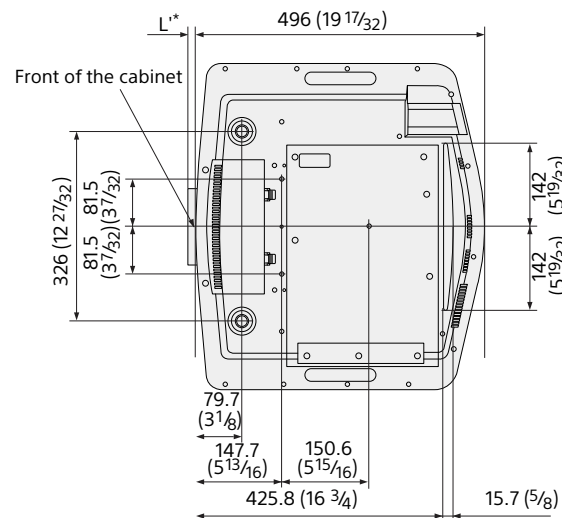

* VPL-VW995ES only
 VPLL-Z7013 (Bundled) : L' = 9.2 (3/8)
 VPLL-Z7008 (Optional) : L' = Tele 43.4 (1 23/32) / Wide 69.5 (2 3/4)

Unit : mm (inches)

VPL-VW695ES/VPL-VW295ES

CONNECTOR PANELS

VPL-VW695ES

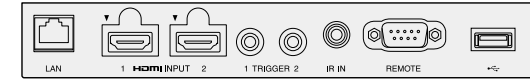

VPL-VW295ES

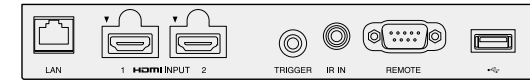

Front

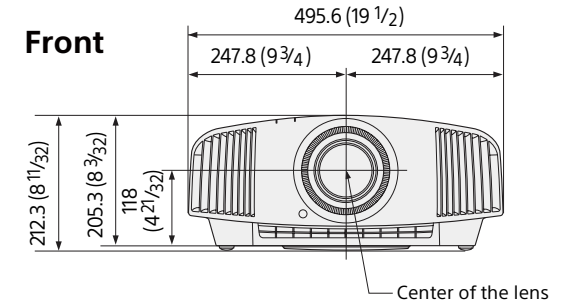

Bottom

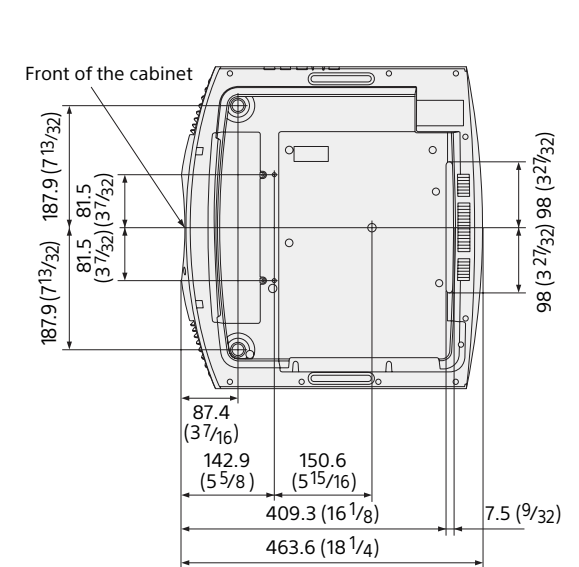

Unit : mm (inches)

VPL-VZ1000ES

CONNECTOR PANELS

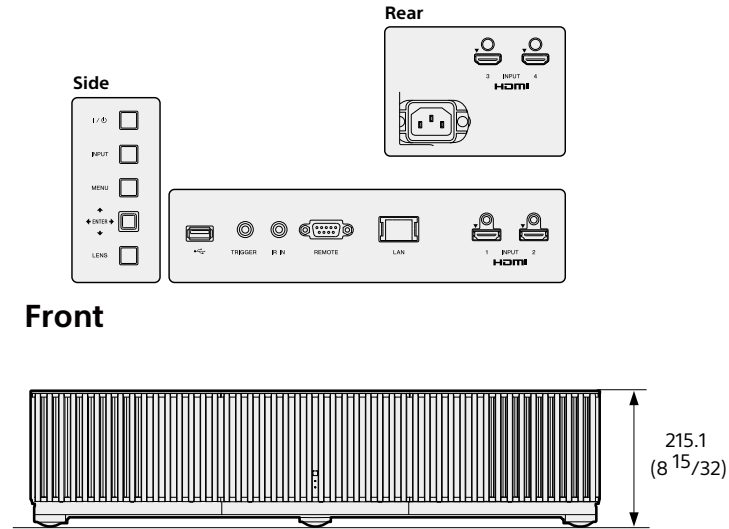

Bottom

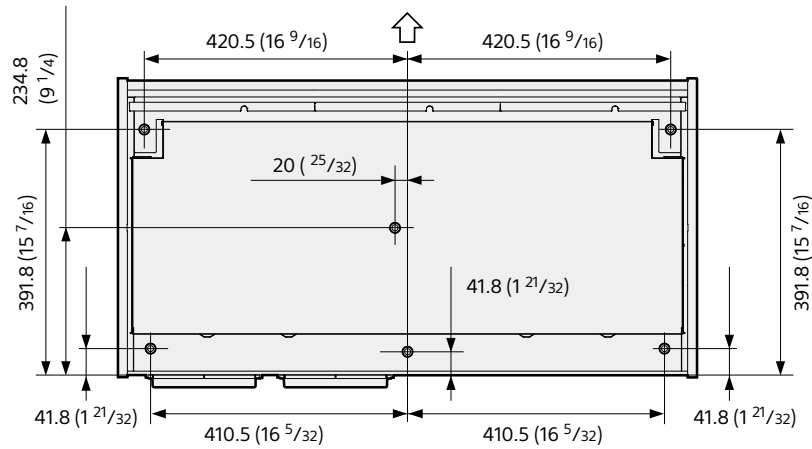

VPL-HW65ES/VPL-HW45ES

CONNECTOR PANELS

VPL-HW65ES

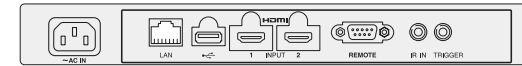

VPL-HW45ES

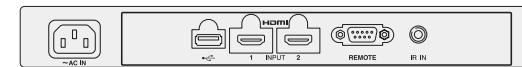

Front

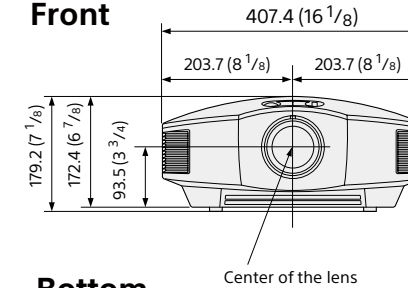

Bottom

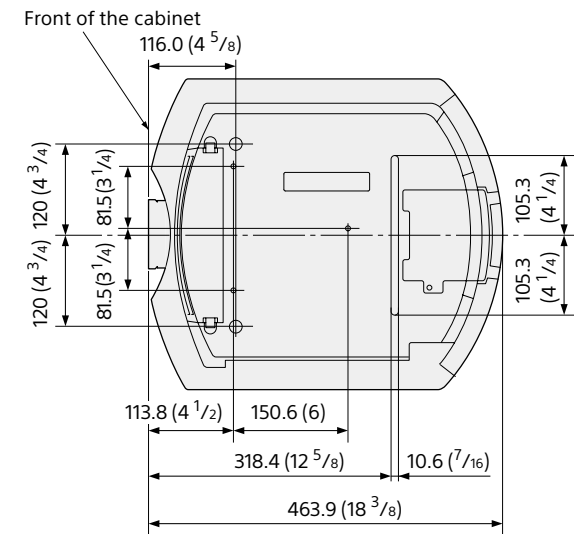

SONY

Distributed by

©2018 Sony Corporation. All rights reserved.
Reproduction in whole or in part without written permission is prohibited.
Features and specifications are subject to change without notice.
The values for mass and dimension are approximate.
"SONY" is a registered trademark of Sony Corporation.
"SXR", "Z-Phosphor", "TRILUMINOS" and
"Remote Commander" are trademarks of Sony Corporation.
The terms HDMI and HDMI High-Definition Multimedia Interface,
and the HDMI Logo are trademarks or registered trademarks of
HDMI Licensing LLC in the United States and other countries.
All other trademarks are the property of their respective owners.
Please visit Sony's professional website or contact your
Sony representative for specific models available in your region.
© & TM 2017 MARVEL. ©2017 CPII and LSC Film Corporation. All Rights Reserved.

MK20294V2YIT18OCT