



## S9GMXU9 New product

Free-Standing Dual-Fuel Range,  
Approx. 36", Stainless Steel

EAN13: 8017709238230

### Professional Style

Stainless steel

Sturdy American-style control knobs

Island trim backsplash

### MULTIFUNCTION ELECTRIC OVEN:

8 cooking modes

Programmable timer with touch display

Air-cooled double-glazed removable door

True European Double convection

EverClean enameled oven interior

5 shelf positions

2 oven lights

Oven capacity: 4.5 cu ft

Bake element 1.2 kW

Broil element 1.8 kW

Convection element 2.9 kW

### GAS RANGETOP:

Heavy-duty cast-iron grates

Full-width grates

Sealed burners

Automatic electronic ignition

Safety valves

LP gas conversion kit included

### 5 GAS BURNERS:

Front-right: 3,400 BTUs

Back-right: 6,200 BTUs

**Central double-inset super burner: 14,000 BTUs**

Front-left: 9,000 BTUs

Back-left: 6,200 BTUs

### SAFETY:

Gas safety valves

Ventilated door with cooling system to prevent  
overheating

Anti-tilting norms satisfied

Suitable for built-in applications

Connected load nominal power: 240/120V – 3.7kW

Amp supply required 240/120V 15 Amps

Voltage rating: 240/120V 60Hz

Gas inlet location: back top-right

### ACCESSORIES INCLUDED:

1 baking tray



2 chrome shelves

1 moka ring

## Functions

---



Main Oven

## Options

---

- **KIT19XU** - Island Trim
- **KITPS9U** - Stainless steel toe kick

**SMEG U.S.A. INC.**  
**A&D BUILDING**  
**150 EAST 58th STREET, 7th FLOOR**  
**NEW YORK, NY, 10155**  
**Tel. +1 212 265 5378**  
**Fax +1 212 265 5945**



## Main Oven



### Bake:

Ideal for slow baked cakes and casseroles. This traditional static heat will ensure food remains moist when cooked for longer periods of time.



### Lower heating element only:

Ideal for foods that require extra base temperature without browning, e.g. pastry dishes, pizza. Also suitable for slow cooking of stews and casseroles. For Gas oven: Bake: traditional convection cooking.



### Half broiler:

For rapid cooking and browning of foods. Best results can be obtained by using the top shelf for small items, the lower shelves for larger ones, such as chops or sausages. For half grill heat is generated only at the centre of the element, so is ideal for smaller quantities.



### Broiler:

For rapid cooking and browning of foods. Best results can be obtained by using the top shelf for small items, the lower shelves for larger ones, such as chops or sausages. For half grill heat is generated only at the centre of the element, so is ideal for smaller quantities.



### Convection broil:

The fan reduces the fierce heat from the broiler, providing an excellent method of grilling various foods, chops, steaks, sausages etc. giving even browning and heat distribution, without drying out the food. The top two levels recommended for use, and the lower part of the oven can be used to keep items warm at the same time, an excellent facility when cooking a grilled breakfast.

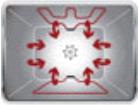

### Convection Bake:

The elements combined with the fan aim to provide more uniform heat, a similar method to conventional cooking, so pre-heat is required. Most suitable for items requiring slow cooking methods.



### European convection:

Hot air fan cooking that provides quick, multi layered cooking with excellent browning results. Due to the effective circulation of hot air, there is no flavour transfer between foods. Delicate and strongly fragranced foods can be cooked at the same time.



### Defrost:

The circulation of air at room temperature enables quicker thawing of frozen food, (without the use of any heat). Ideal for use prior to cooking of readymade dishes, or cream filled products etc.



# S9GMXU9

36"  
stainless steel  
cooktops type: gas  
oven type: electric multifunction

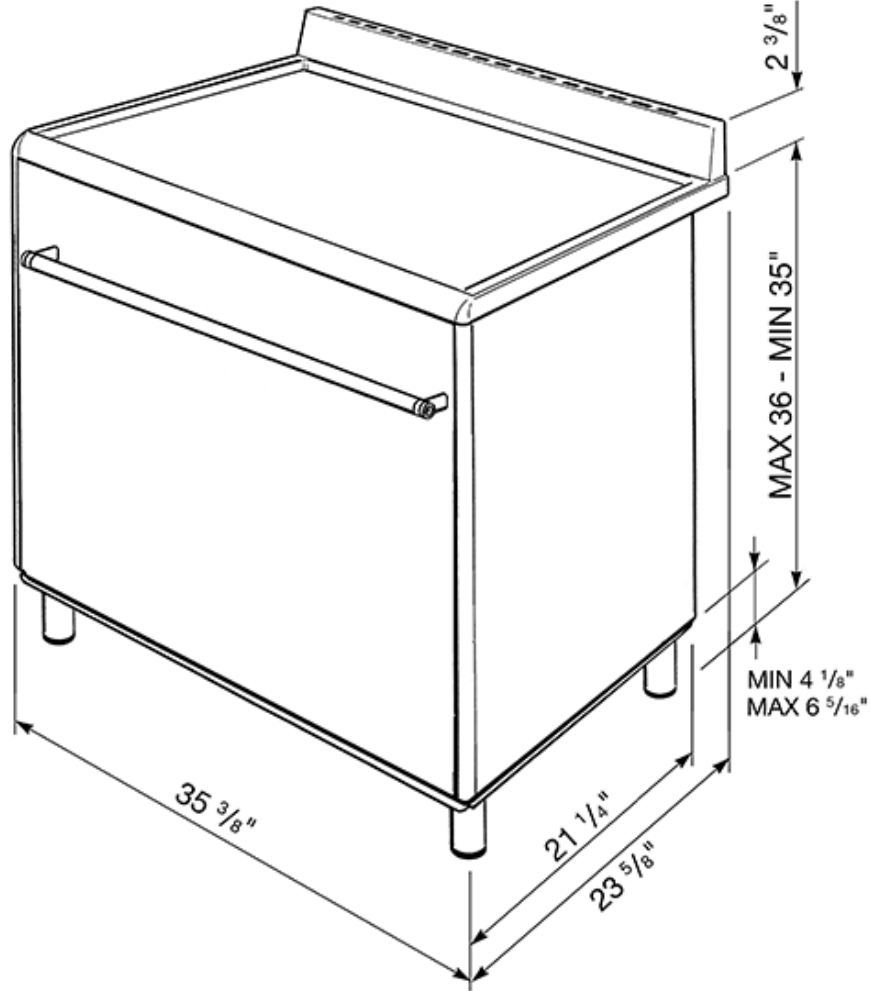

SMEG U.S.A. INC.  
A&D BUILDING  
150 EAST 58th STREET, 7th FLOOR  
NEW YORK, NY, 10155  
Tel. +1 212 265 5378  
Fax +1 212 265 5945