

FQ50UFXE New product

classic

90 CM (Approx 36"), French Door Refrigerator/Freezer,
2 doors and 2 drawers, Stainless steel

EAN13: 8017709255275

Free-standing refrigerator

Standard hinge

Counter depth

Fingerprint-proof stainless steel finish

Display: LCD touch

Display functions: Holiday, Fast Freezing,

Fast Cooling, Multizone, Energy Efficiency Mode,

Child Safety Lock, Door Open Alarm

Adaptable compartment (freezer or refrigerator space)

REFRIGERATOR COMPARTMENT FEATURES:

Life Plus Zone 32° F

2 glass adjustable shelves

2 fruit and vegetables drawers

Glass crisper cover

LED refrigerator internal light

REFRIGERATOR INNER DOOR:

2 door balconies with transparent cover

4 adjustable balconies

2 bottle balconies

1 egg tray

FREEZER COMPARTMENT FEATURES:

2 drawers

No-frost

Automatic ice maker

Ice tray shelf

PERFORMANCE/ENERGY LABEL:

Annual energy consumption: 623 kWh

Fresh food compartment net volume: 14.70 cu ft

Freezer compartment net volume: 5.97 cu ft

Frozen food compartment star rating: 4

Frost-free system

Freezing capacity: 28.7 lbs/h

Noise level: 45 dB(A)

ELECTRICAL CONNECTION:

Electrical connection rating: 160 W

Current: 2.7 Amp

Voltage: 120V

Frequency: 60Hz



Functions



**SMEG U.S.A. INC.
A&D BUILDING
150 EAST 58th STREET, 7th FLOOR
NEW YORK, NY, 10155
Tel. +1 212 265 5378
Fax +1 212 265 5945**



FQ50UFXE

classic

fridge
free standing
2 doors and 2 drawers
stainless steel
36"



Energy Star and ISO14001 Certified:

The Smeg production process is carefully managed in order to keep the impact upon the environment as low as possible. The process is checked and certified by Independent International bodies IQNET and CISQ (Smeg complies with the standard ISO14001). All Smeg dishwashers are ENERGY STAR qualified. Energy efficiency is important to Smeg and our technicians are constantly working to keep the energy, and water, consumption of each dishwasher as low as possible. ENERGY STAR certified products use less water than conventional dishwashers, and approximately 40% less energy than the federal minimum standard for energy consumption. By choosing an ENERGY STAR certified product you are helping to preserve the environment without compromising on product quality or performance.



**SMEG U.S.A. INC.
A&D BUILDING
150 EAST 58th STREET, 7th FLOOR
NEW YORK, NY, 10155
Tel. +1 212 265 5378
Fax +1 212 265 5945**



FQ50UFXE

classic

fridge
free standing
2 doors and 2 drawers
stainless steel
36"

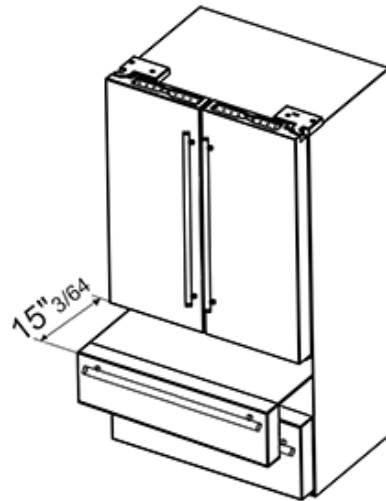
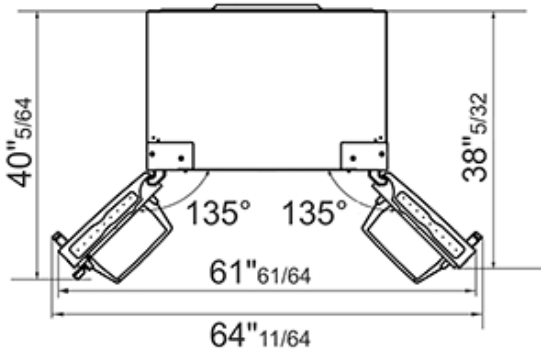
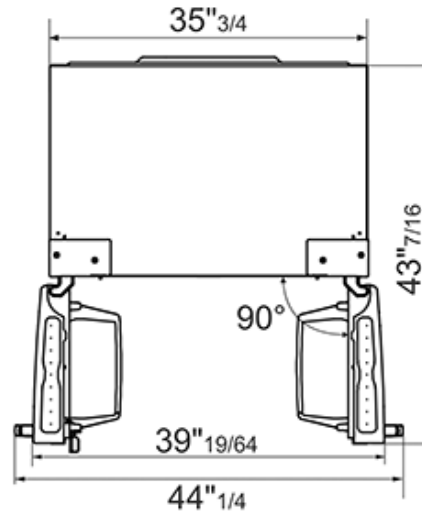
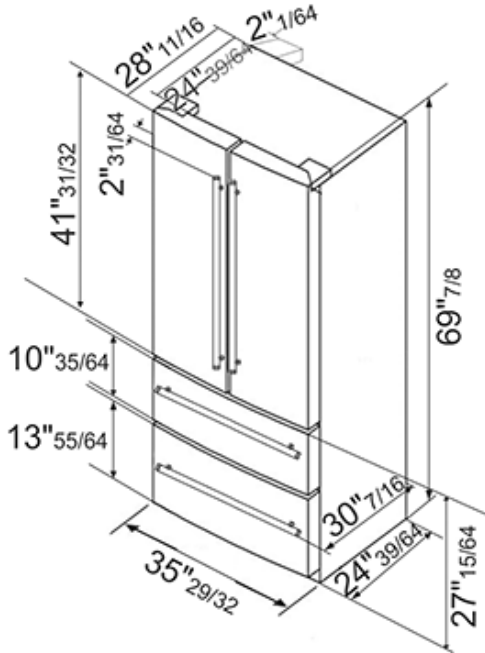

SMEG U.S.A. INC.
A&D BUILDING
150 EAST 58th STREET, 7th FLOOR
NEW YORK, NY, 10155
Tel. +1 212 265 5378
Fax +1 212 265 5945