

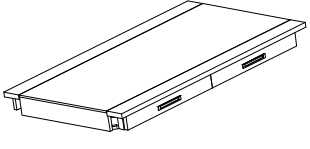





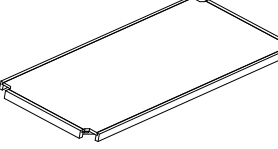
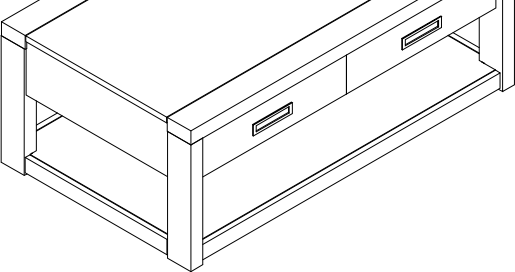
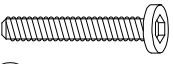

Components and Hardware List

<p>Table Top</p>  <p>(A) 1 pc</p>	<p>Left Legs</p>  <p>(B) 2 pcs</p>	<p>Right Legs</p>  <p>(C) 2 pcs</p>	<p>Bottom Shelf</p>  <p>(K) 1 pc</p>	 <p>75802 Rectangle Cocktail Table</p>	
<p>M5/16" x 2" Allen Head Bolt</p>  <p>(D) 12 pcs.</p>	<p>5/16" Spring Washer</p>  <p>(E) 12 pcs.</p>	<p>5/16" Flat Washer</p>  <p>(F) 12 pcs.</p>	<p>5mm Allen Wrench</p>  <p>(G) 1 pc.</p>	<p>∅50mm Caster</p>  <p>(H) 4 pc.</p>	<p>Open Wrench</p>  <p>(I) 1 pc.</p>

Step 1: Place the Table Top upside down on a soft surface such as a blanket or carpet and remove the drawers.

Step 2: Attach three Legs (B & C) into the proper corners of the Table Top (A) using the Allen Head Bolts (D), Spring Washers (E) and Flat Washers (F). Do not fully tighten until after Step 4.

Step 3: Carefully position the Bottom Shelf (K) into the notches of the three legs attached to the Table Top.

Step 4: Position the fourth Leg into the corner of the Table Top and Shelf and attach using the same Bolts and Washers as before.

Step 5: Tighten all Bolts with the Allen Wrench (G)

Step 6: If the Casters (H) will be used, install into the four mounting holes on the bottom side of the Shelf. Tighten with the Open Wrench (I).

Step 7: Carefully set the assembled table upright and reinstall the Drawers.

The casters provide an element of convenient mobility, however, to prevent possible damage to some types of flooring, never roll casters on unprotected hardwood, or vinyl flooring.

Steps 2, 3, 4, 5, 6

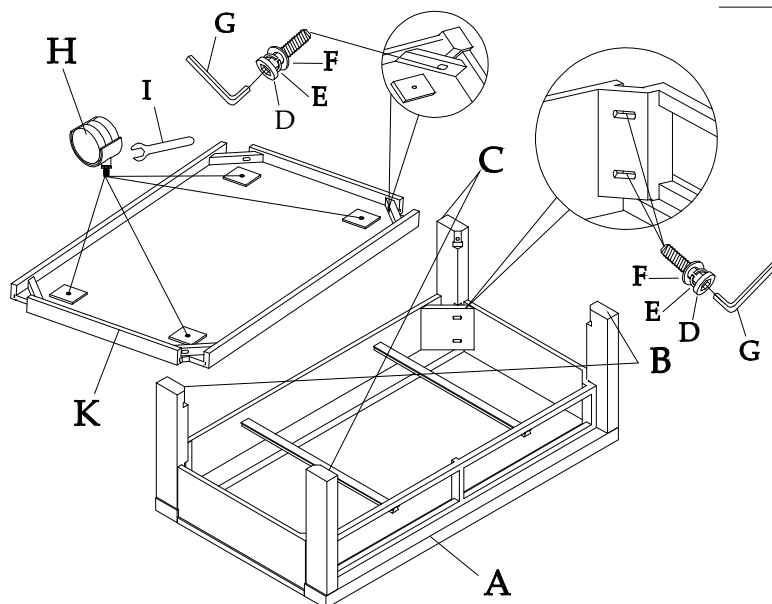

NOTE

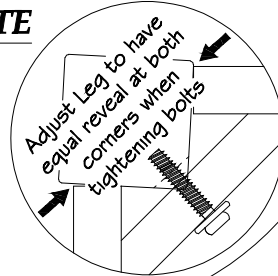

Step 7

