

INSTALLATION INSTRUCTIONS

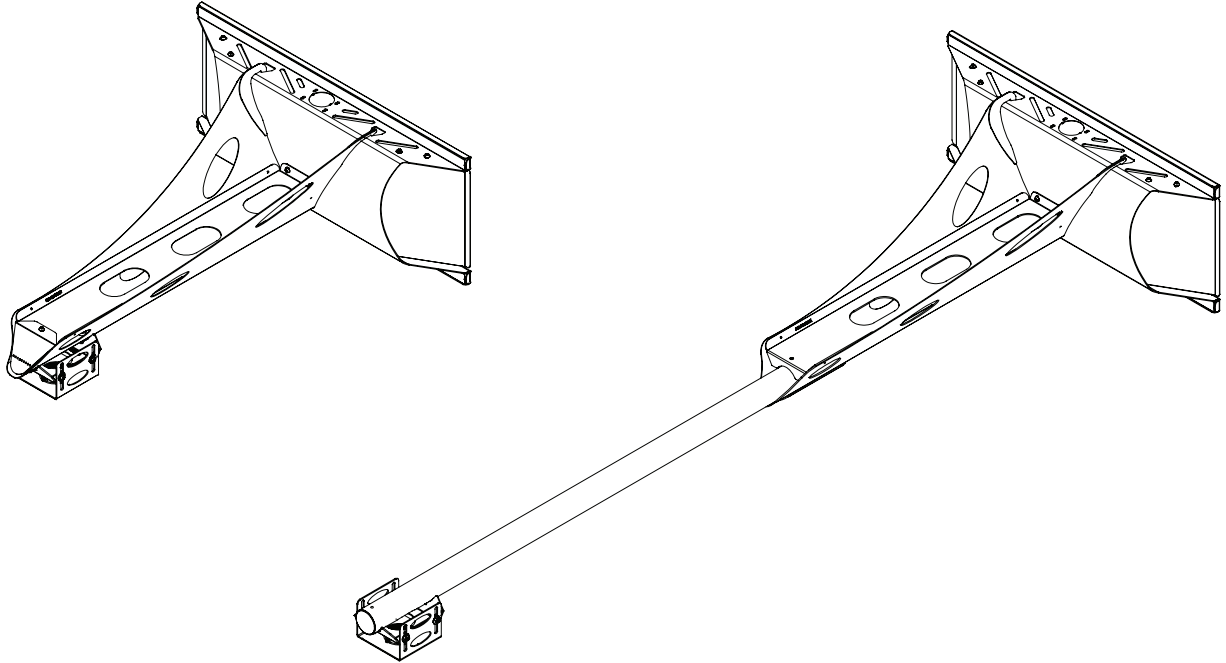

Universal Short Throw Projector Wall Mount Model: UNI/UNIE

NORTH AMERICA

3130 East Miraloma Avenue
Anaheim, CA 92806 USA
USA and Canada
Phone: 1-800-368-9700
Fax: 1-800-832-4888
Other Locations
Phone: (001) 714-632-7100
Fax: (001) 714-632-1044

EUROPE

Swallow House,
Shilton Industrial Estate,
Shilton, Coventry, England CV79JY
Phone: +44 (0) 2476 614700
Fax: +44 (0) 2476 614710



Table of Contents

Weight Capacity	2
Warning Statements	2
Installation Tools	3
Parts List	3
Features	4
Determining the Installation Height	5
Wood Stud Installation	6
Attaching the Projector Arm	7
Throw Distance Calculation	8
Attaching the Projector Mount	9
Extension Arm Installation (Optional)	12
Adjustable Mounting Bracket Installation	13
Utilizing the Storage Feature	14
Cable Management	15
Technical Specifications	16
Warranty	17
Disclaimer	17

Weight Capacity

Maximum projector weight: **50 lb.**

THE WALL STRUCTURE MUST BE CAPABLE OF HOLDING FIVE (5) TIMES THE WEIGHT OF THE PROJECTOR. IF NOT, THEN THE WALL STRUCTURE MUST BE REINFORCED.

Warning Statements

 PRIOR TO THE INSTALLATION OF THIS PRODUCT, THE INSTALLATION INSTRUCTIONS SHOULD BE READ AND COMPLETELY UNDERSTOOD. THE INSTALLATION INSTRUCTIONS MUST BE READ TO PREVENT PERSONAL INJURY AND PROPERTY DAMAGE. KEEP THESE INSTALLATION INSTRUCTIONS IN AN EASILY ACCESSIBLE LOCATION FOR FUTURE REFERENCE.

 PREMIER MOUNTS DOES NOT WARRANT AGAINST DAMAGE CAUSED BY THE USE OF ANY PREMIER MOUNTS PRODUCT FOR PURPOSES OTHER THAN THOSE FOR WHICH IT WAS DESIGNED OR DAMAGE CAUSED BY UNAUTHORIZED ATTACHMENTS OR MODIFICATIONS, AND IS NOT RESPONSIBLE FOR ANY DAMAGES, CLAIMS, DEMANDS, SUITS, ACTIONS OR CAUSES OF ACTION OF WHATEVER KIND RESULTING FROM, ARISING OUT OF OR IN ANY MANNER RELATING TO ANY SUCH USE, ATTACHMENTS OR MODIFICATIONS.

 SAFETY MEASURES MUST BE PRACTICED AT ALL TIMES DURING THE ASSEMBLY OF THIS PRODUCT. USE PROPER SAFETY GEAR AND TOOLS FOR THE ASSEMBLY PROCEDURE TO PREVENT PERSONAL INJURY.

 At least two qualified people should perform the assembly procedure. Injury and/or damage can result from dropping or mishandling the projector.

 If mounting to studs, make sure that the mounting screws are anchored into the center of the studs. Use of an edge-to-edge stud finder is recommended.

 Be aware of the mounting environment. If drilling and/or cutting into the mounting surface, always make sure that there are no electrical wires in wall. Cutting/drilling into an electrical line may cause serious injury.

 Make sure there are no water lines inside the wall where the mount is to be located. Cutting/drilling into a water line may cause severe water damage to the mounting surface.

 This product is intended for indoor use only. Use of this product outdoors could lead to product failure and personal injury.

 Do not install near sources of high heat. Do not install on a structure that is prone to vibration, movement or chance of impact

 Contact Premier Mounts with any questions
 (800) 368-9700
 techsupport@mounts.com



Installation Tools

The following tools may be required depending upon your particular installation. They are not included.

Parts List

Make sure your Premier Mounts product has the following hardware and components before beginning installation. If there are parts missing and/or damaged, stop the installation and call Premier Mounts at (800) 368-9700.

UNI/UNIE Hardware					
 Wall Plate (Qty 1)	 Arm Assembly (Qty 1)	Extension Hardware Pack M6 x 12mm Security Screws (pre-assembled) (Qty 2) M6 Flat Washer (Qty 2)		Extension Arm - Optional (Qty 1) included with the UNIE External Slide Plate (Qty 1)	
 End Cover (Qty 1)	 Adjustable Mounting Assembly - Pre-Assembled (Qty 1)	 Internal Slide Plate (Qty 1)	 Back Plate Covers (Qty 2)		
 M4 x 10mm Security Screws for FTP Install (Qty 4)	 M6 x 12mm Security Screws for PDS Install (Qty 2)	 M5 x 8mm Security Screws (Qty 7)	 M6 x 16mm Security Screws (Qty 2)	 5/16" x 3" Lag Bolts (Qty 4)	 M5 Allen Wrench (Qty 1)
 1/4" Nylon Spacer (Qty 2)	 Square Washers (Qty 4)				



Features

Premier Mounts' universal short-throw projector arm (UNI/UNIE) is one of the most flexible and installer-friendly short-throw arms on the market. It adjusts from 7" to 27" [up to 67" from the wall when used with an arm extension (UNIE)]. To make installation even easier, an array of mounting points at the top and bottom of the GearBox™ allows you to mount the UNI/UNIE off-center from the whiteboard/screen, if needed. The UNI/UNIE mounts to a single stud or dual studs at 16", 18" or 24" spacing, and includes a Fine-Tune Projector (FTP), PDS or SpiroLock™ projector mount.

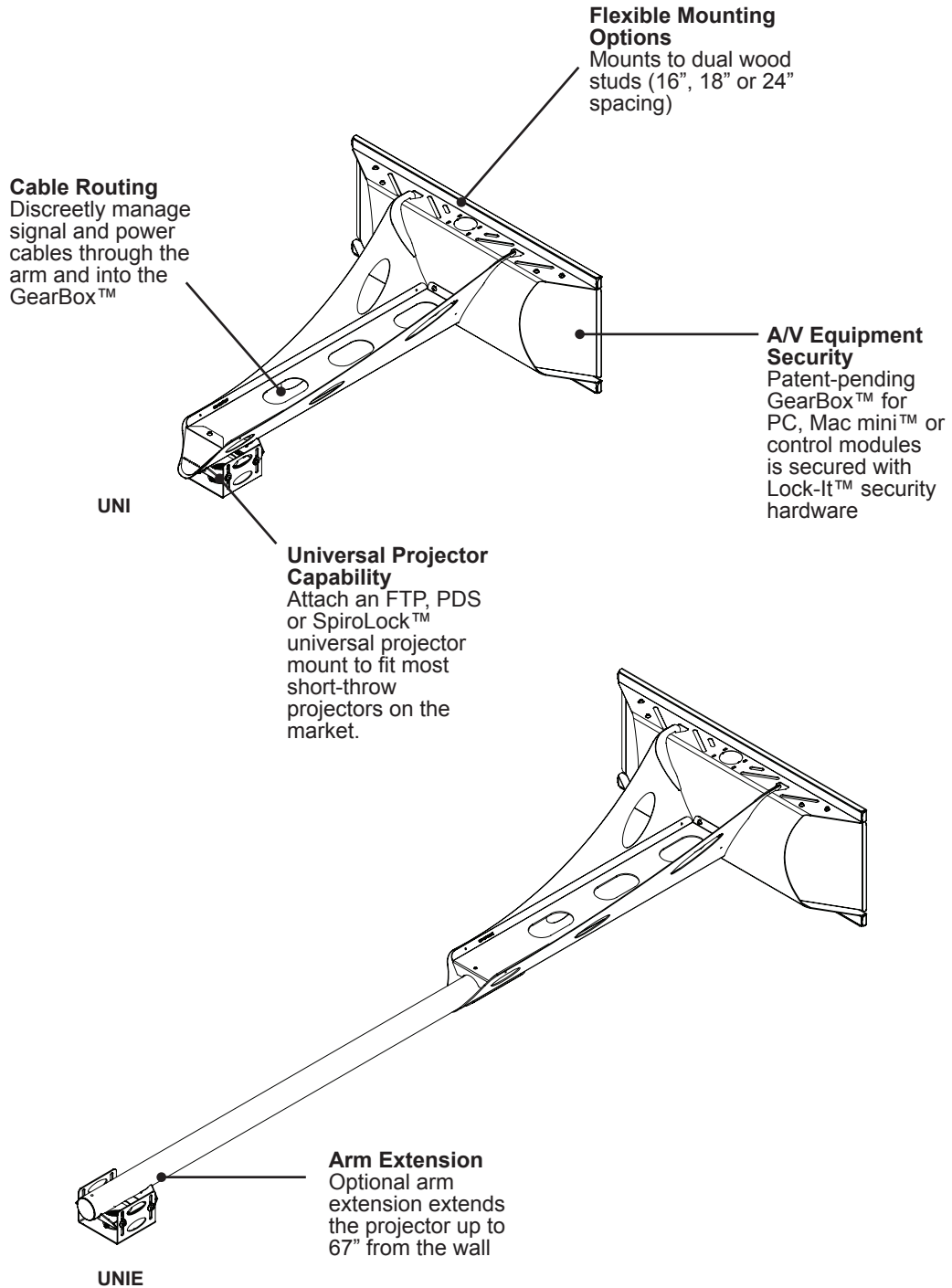



Determining the Installation Height

 The UNI/UNIE is designed for use with the Fine-Tune Projector (FTP), PDS or SpiroLock™ projector mounts. In order to determine the installation height and throw distance, their projector mounting bracket must be mounted to the projector. Please refer to the projector mount installation instructions prior to performing the following steps.

 Refer to the projector's user's manual to determine the offset of the projector lens to the top of the screen/whiteboard (B).

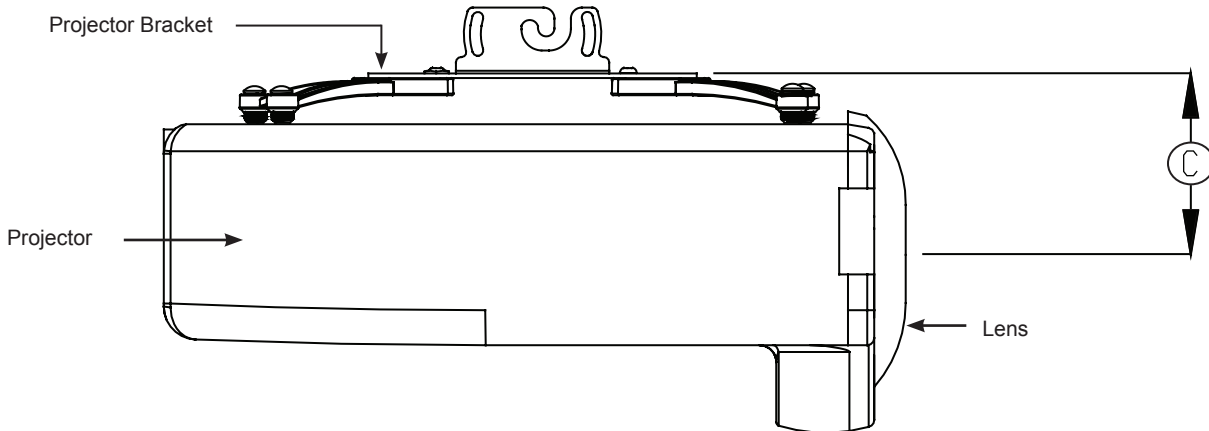

- 1 Measure distance from center of lens to the top of the projector mounting bracket (C).
- 2 Add the distance from the ground to the top of the screen (A). Add the projector manufacturers recommended offset from the projector manual (B), then add the measurement from Step 1 (C). Lastly, add 2.5" if you are using a PDS mount, 2.8" if SpiroLock™ or 3.8" if FTP.
(Example: $A + B + C + 2.5''$ or $2.8''$ or $3.8'' = ?$)
- 3 Add the measurements to determine the mounting height mark. Place a mark at the top of the total calculated height measurement starting from the ground up. This mark will represent the lower edge of the wall plate.

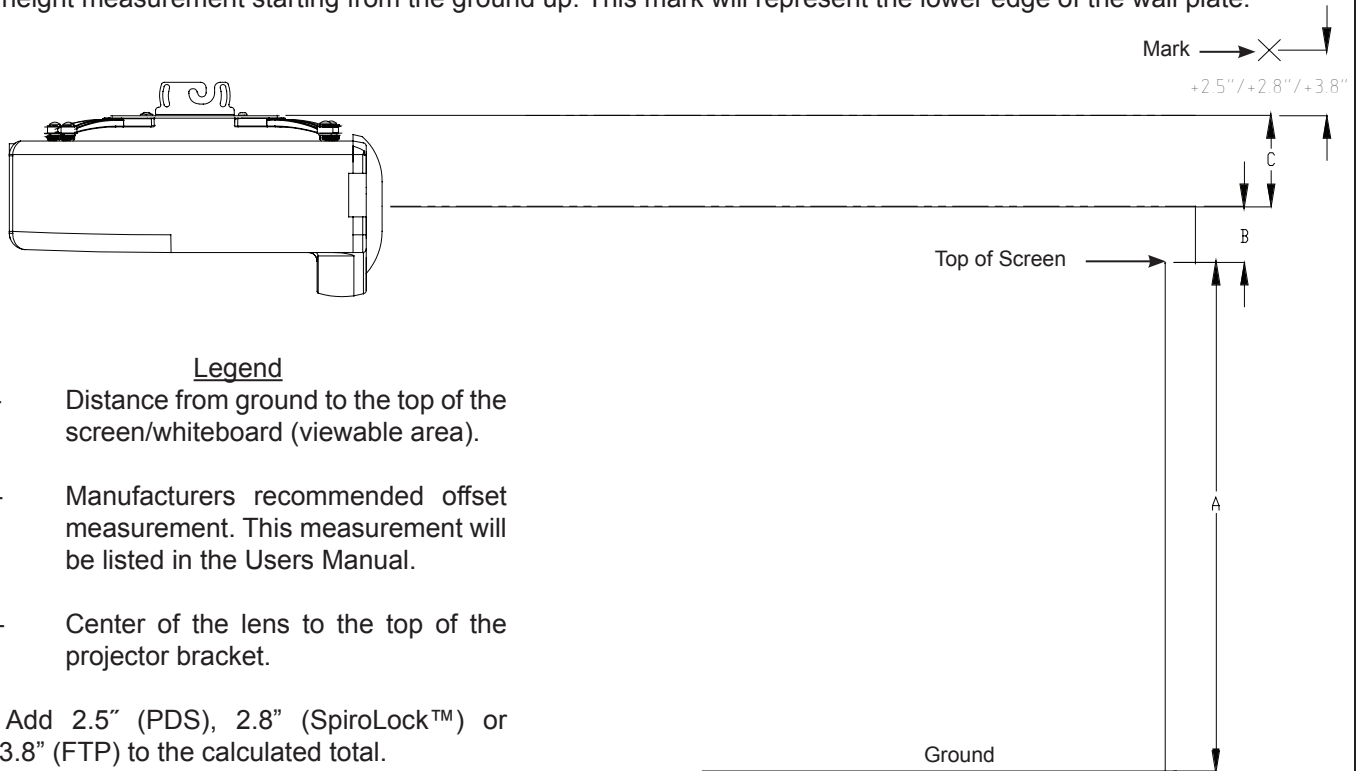

Legend

- A - Distance from ground to the top of the screen/whiteboard (viewable area).
- B - Manufacturers recommended offset measurement. This measurement will be listed in the Users Manual.
- C - Center of the lens to the top of the projector bracket.

Add 2.5" (PDS), 2.8" (SpiroLock™) or 3.8" (FTP) to the calculated total.

This total distance will be the location for the bottom rail on the wall plate.

Proceed to the **"Wood Stud Installation"** section.



Wood Stud Installation

 Do NOT over-tighten lag bolts when attaching the mount to the wall. Improper installation may result in personal injury or damage to property.

 THE EXACT CENTER OF THE STUD MUST BE LOCATED FOR CORRECT AND SAFE INSTALLATION.

Step 1

Use an electronic stud finder (not supplied) to locate the center of the stud that is in the wall.

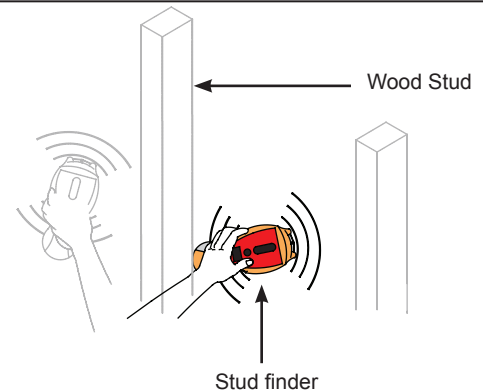

Step 2

Use a pencil to mark the first mounting point, just above your height mark (from page 5).

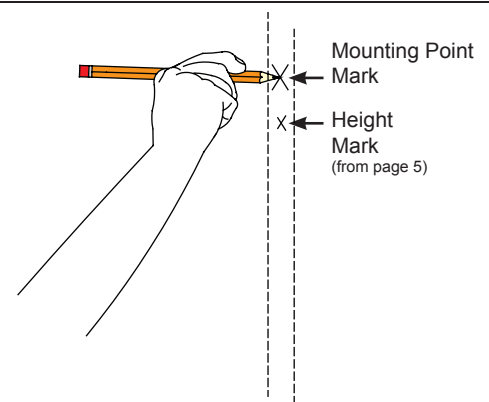

Step 3

- 1 Use the level to make sure the wall plate is level from side to side.
- 2 Place the wall plate over the first mounting point mark and use a pencil to mark the rest of the mounting points.



Four (4) mounting points must be used. Two (2) upper mounting points and two (2) lower mounting points.

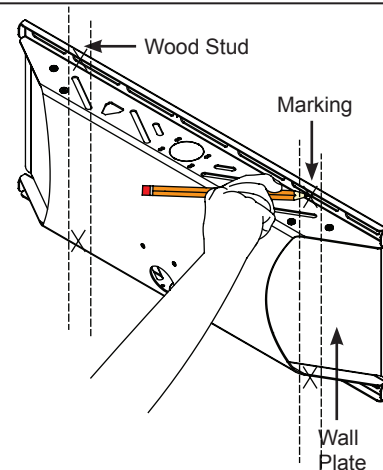

Step 4

Once the mounting points have been marked, use a $\frac{1}{4}$ " drill bit and portable drill to drill the pilot holes.

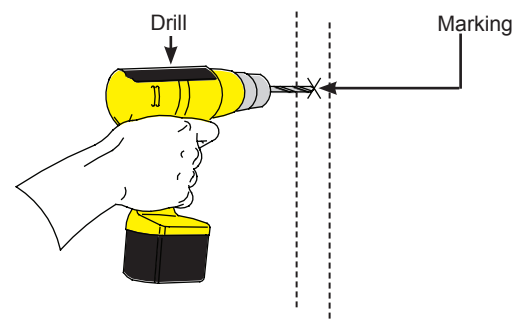



Step 5

After the pilot holes have been drilled, use four (4) $\frac{5}{16}$ " x 3" lag bolts and four (4) square washers to mount the wall plate to the wooden studs.

Use a $\frac{1}{2}$ " socket and socket wrench to finish this step.

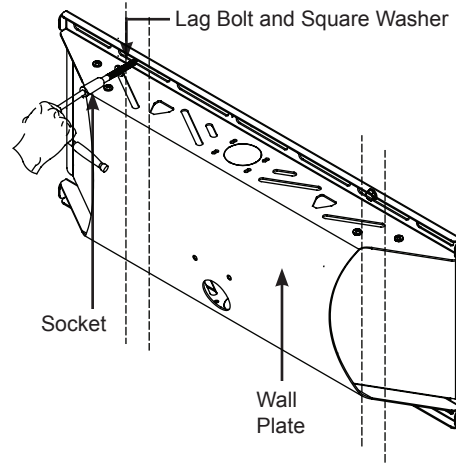

Step 6

Insert and gently tap the upper and lower back plate covers into place.

Proceed to the "Attaching the Projector Arm" section.

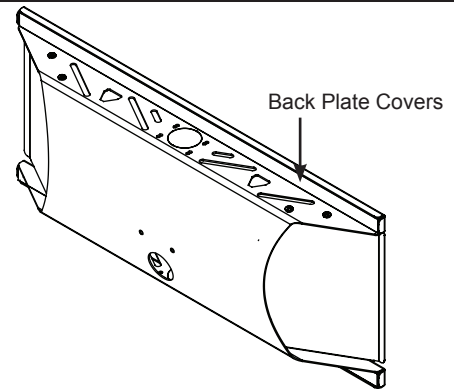

Attaching the Projector Arm

Step 1

- 1 Locate the mounting hook cutout on the top of the wall plate.
- 2 Tilt the arm slightly and gently insert the mounting hooks into the mounting hook cutouts.
- 3 Slowly lower and let the projector arm rest against the wall plate.



If using the storage feature of the product, it may be easier to route any wiring at this time (please see Page 15).



MAKE SURE THE PROJECTOR ARM IS FULLY SEATED BEFORE RELEASING THE UNIT.

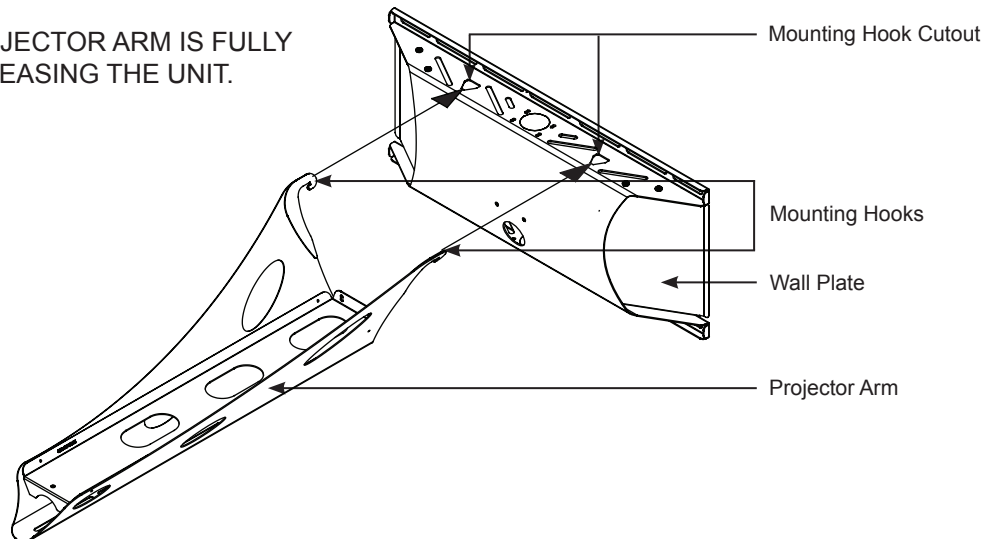



Step 2

- 1 Locate the two (2) lock mounting points on the projector arm. These two points will be aligned with the lock mounting points on the wall plate.
- 2 Using a security wrench, insert and tighten two (2) M5 x 8mm security head screws.



Do NOT overtighten these screws.

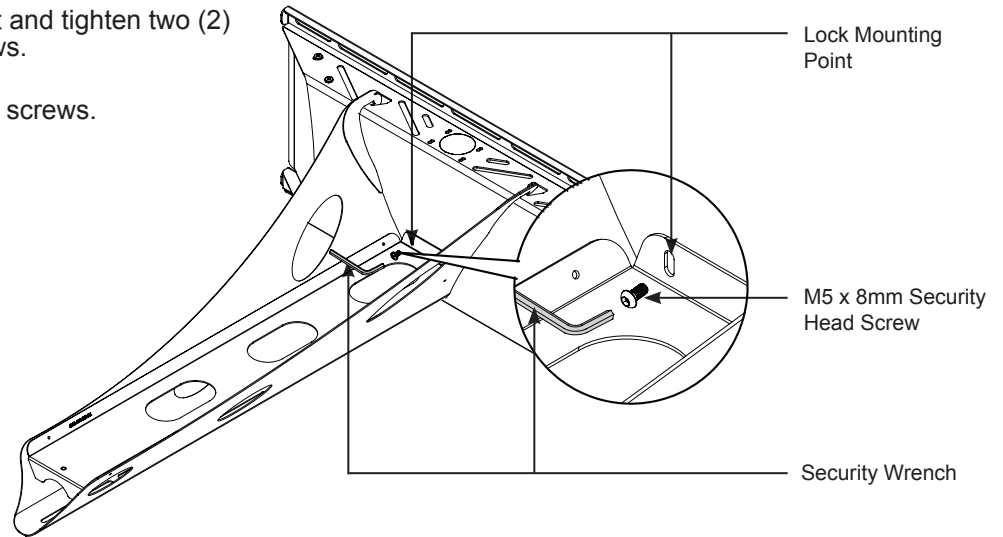

Throw Distance Calculation



Please review your projector mount's user manual before attaching the upper mounting bracket. The correct throw distance (the distance from the projector to the screen) must be determined prior to mounting the projector.

- 1 Refer to the projector's user's manual to determine the distance from the lens to the front of the screen (X).
- 2 Measure the distance from the front of the lens to the center of the projector (Y).
- 3 Measure the distance from the wall to the face of the whiteboard/screen (Z).
- 4 Add all measurements (X + Y + Z) to determine projector placement on the arm assembly. This measurement will determine where the center of the mount bracket will be located on the arm assembly. Please make note of this measurement.

Calculations

X = Manufacturers recommended throw distance

Z = Distance from wall to face of whiteboard/screen

Front Lens Throw Distance =
(X + Y + Z)

Rear Lens Throw Distance =
(X - Y + Z)

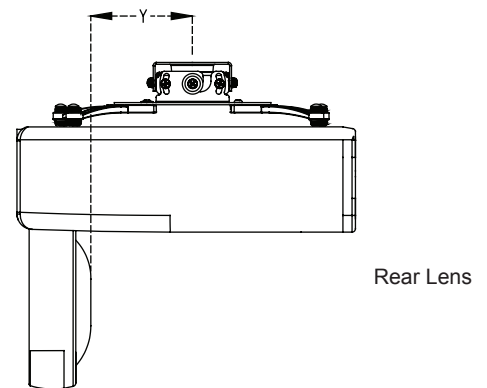
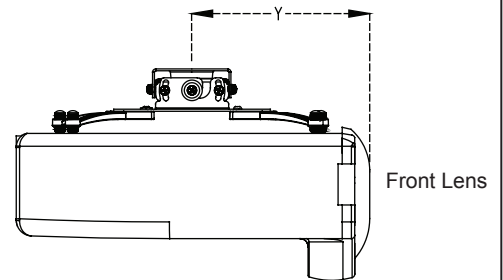

The UNI/UNIE can be also used as a wall-mounted standard projector mount as well as a short throw projector mount. Align the projector facing the opposite direction from the wall plate to project the image across the room. Please take into account the projectors throw capabilities prior to mounting in the projector opposite direction.

Continue to the “Attaching the Projector Mount” section.



Attaching the Projector Mount

? What kind of projector mount are you attaching to the adjustable mounting assembly?

If it is a Fine-Tune Projector (FTP) mount, continue to the “**Installing an FTP Mount**” section below.

If it is a SpiroLock™ mount, proceed to the “**Installing an SpiroLock™ Mount**” below.

If it is a PDS mount, proceed to the “**Installing a PDS Mount**” section on page 10.

 Attach the projector mount to the mounting assembly before attaching the projector itself.

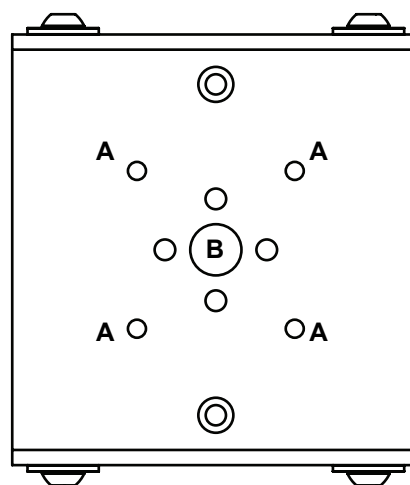

Bottom view of the adjustable mounting assembly

Figure 1

Installing an FTP Mount

- 1 Detach the upper half of the mounting assembly from the lower half.
- 2 Following the “A” mounting-hole pattern (Figure 1), use four (4) M4 x 10mm security screws to attach the FTP projector mount to the lower half of the mounting assembly (Figure 2). Do not overtighten.

 Use the four mounting holes on the collar of the FTP.

- 3 Re-attach both components of the mounting assembly.

 Refer to the FTP user manual for instructions on attaching the projector to the mount.

? Are you attaching an extension arm?

If yes, continue to the “**Extension Arm Installation (Optional)**” section on page 12.

If no, proceed to the “**Adjustable Mounting Bracket Installation**” section on page 13.

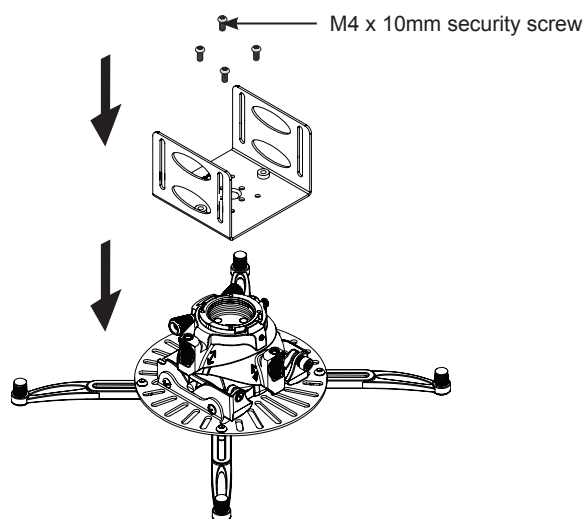



Figure 2

Installing a SpiroLock™ Mount

- 1 Detach the upper half of the mounting assembly from the lower half.
- 2 Following the “B” mounting-hole pattern (Figure 1), use one (1) M8 x 16mm flathead security screw to attach the SpiroLock™ projector mount to the lower half of the mounting assembly (Figure 3). Do not overtighten.

 The M8 x 16mm flathead security screw is included with the SpiroLock™.

- 3 Re-attach both components of the mounting assembly.

 Refer to the SpiroLock™ user manual for instructions on attaching the projector to the mount.

? Are you attaching an extension arm?

If yes, continue to the “**Extension Arm Installation (Optional)**” section on page 12.

If no, proceed to the “**Adjustable Mounting Bracket Installation**” section on page 13.

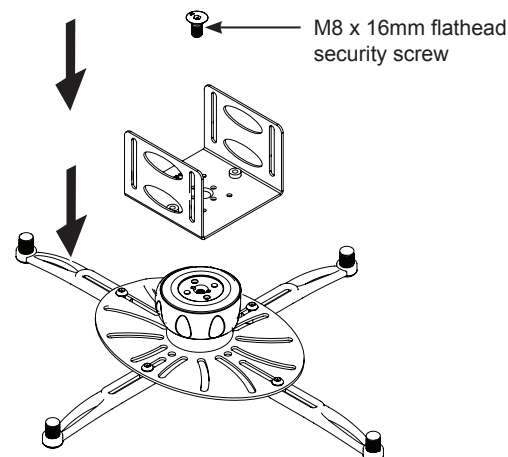

Figure 3



Attaching the Projector Mount (cont'd)

Installing a PDS Mount

? How will you attach the PDS mount?

If you are using the adjustable mounting assembly, continue to the **“Attaching the PDS to the Adjustable Mounting Assembly”** section below.

If you are using only the upper mounting plate for an even lower profile, proceed to the **“Attaching the PDS to the Upper Mounting Plate”** section on page 11.

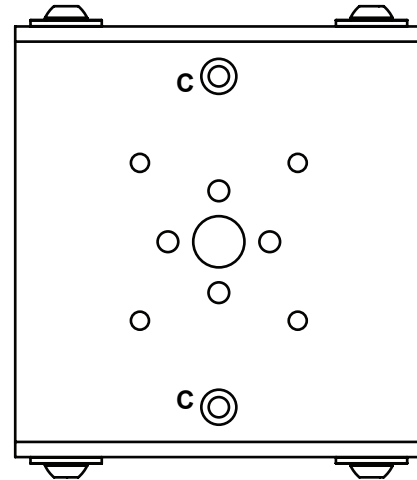

Bottom view of the adjustable mounting assembly

Figure 1

Attaching the PDS to the Adjustable Mounting Assembly

- 1 Detach the upper half of the mounting assembly from the lower half.
- 2 Following the “C” mounting-hole pattern (Figure 1), use two (2) M6 x 12mm security head screws to attach the PDS base box to the lower half of the mounting assembly (Figure 2).

 You must insert the screws from the bottom of the PDS base box. Detach the base box from the mount, if needed.

- 3 Re-attach both components of the mounting assembly.

 Refer to the PDS user manual for instructions on attaching the projector to the mount.

 Do NOT overtighten these screws.

? Are you attaching an extension arm?

If yes, continue to the **“Extension Arm Installation (Optional)”** section on page 12.

If no, proceed to the **“Adjustable Mounting Bracket Installation”** section on page 13.

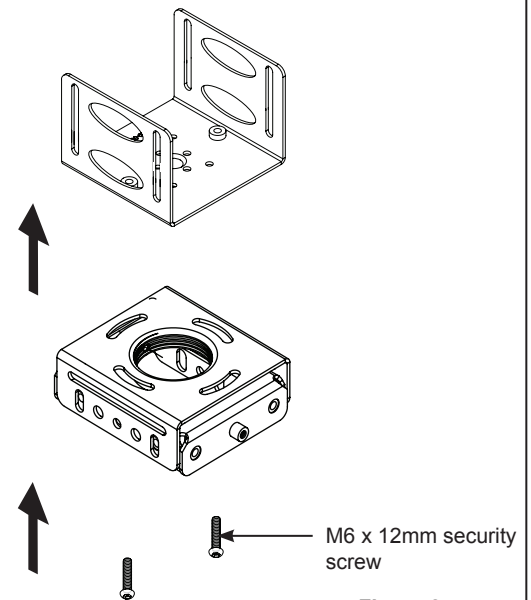

Figure 2



Attaching the PDS to the Upper Mounting Plate



Projector dimensions differ between manufacturers. If the projector hangs too low from the UNI/UNIE, the adjustable mounting bracket may be removed. This will allow you to attach the base box directly to the upper mounting bracket for an even lower profile installation.

- 1 Detach the upper half of the mounting assembly from the lower half.
- 2 Use two (2) M6 x 12mm security head screws to attach the PDS base box to the upper mounting plate (Figure 2).



You must insert the screws from the bottom of the PDS base box. Detach the base box from the mount, if needed.



Refer to the PDS user manual for instructions on attaching the projector to the mount.



Do NOT overtighten these screws.



Are you attaching an extension arm?

If yes, continue to the “**Extension Arm Installation (Optional)**” section on page 12.

If no, proceed to the “**Adjustable Mounting Bracket Installation**” section on page 13.

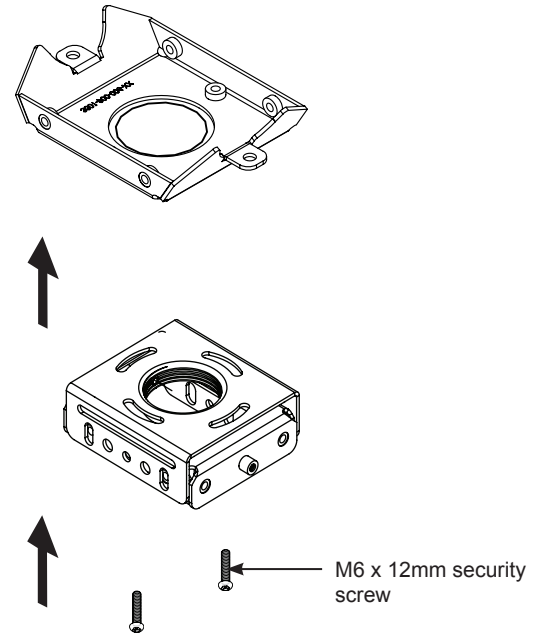

Figure 2



Extension Arm Installation (Optional)

Please see the Operator's Manual to determine the correct throw distance (the distance from the projector to the screen). The throw distance must be determined prior to mounting the projector (Page 8).

If the extension arm is purchased at a later date, the end cover must be removed prior to installing the extension arm.

- 1 Slide the extension arm into the open end of the UNI (the front of the mount).
- 2 Adjust the length so that the center of the adjustable mounting bracket matches the throw distance calibration.
- 3 Line up the mounting holes on the extension arm with the mounting slots on the UNI.
- 4 Using a screwdriver, insert and tighten two (2) M6 x 12mm security head screws and M6 flat washers through the external slide plate and tighten.

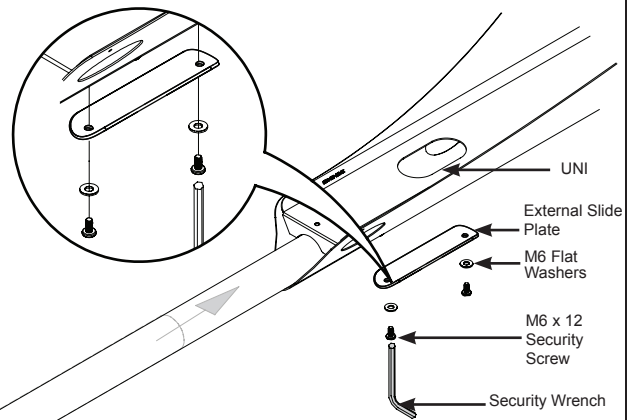

Proceed to the “Adjustable Mounting Bracket Installation” section.

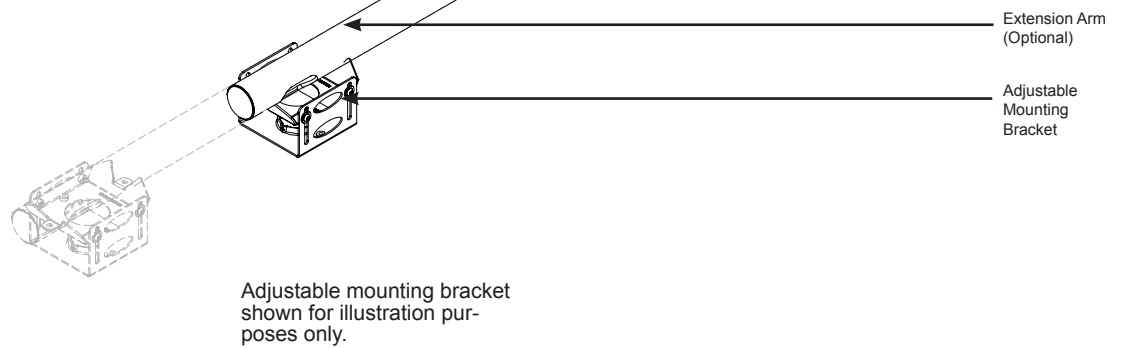



Adjustable Mounting Bracket Installation



If you are using the PDS and upper mounting plate assembly, you can still follow the instructions below to attach it to the projector arm.

- 1 Insert the internal slide plate into the projector arm.
- 2 Determine which adjustment slot best matches your throw distance calculation (see page 8).
- 3 Raise the adjustable mounting bracket into position.
- 4 Align the mounting holes of the upper mounting plate with the mounting holes of the inner slide plate.



Two (2 - one per screw) 1/4" nylon washers must be placed between the adjustable mounting bracket and the projector arm (see inset to the right).

- 5 Secure and finger-tighten two (2) M6 x 16mm security head screws.
- 6 If needed, determine the Throw Distance again.
- 7 Once the correct throw distance has been determined, use the security wrench (supplied) to tighten the mounting screws.

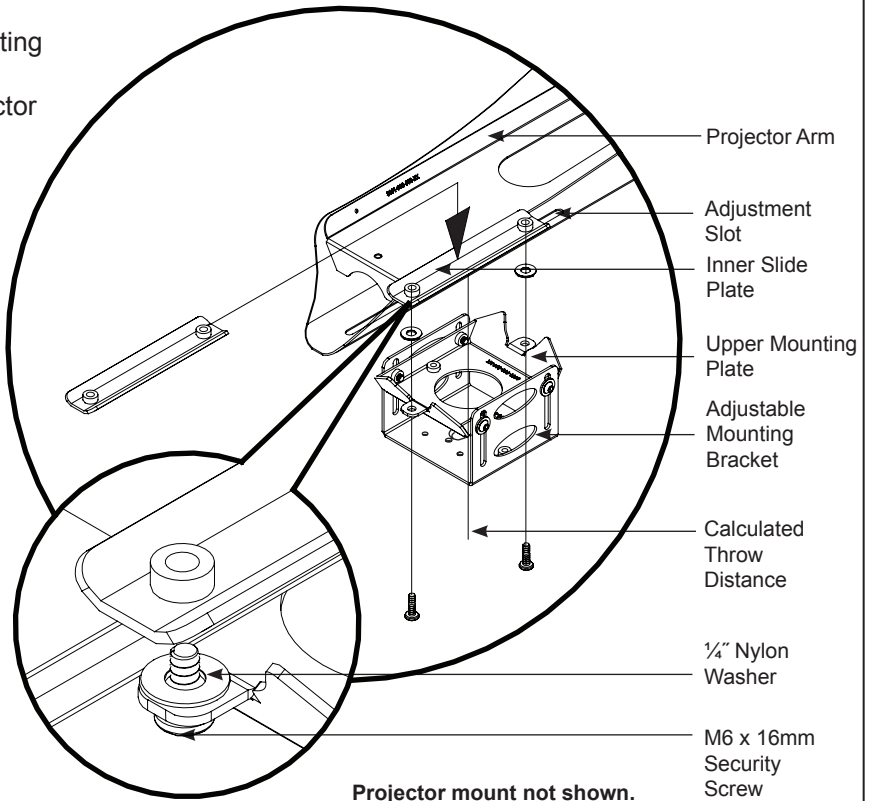

If the adjustable mounting bracket needs to be adjusted, the four (4) M6 x 12mm security screws may be loosened so that the bracket can be moved $\pm 2"$. Once the desired height has been achieved, re-tighten the hardware.

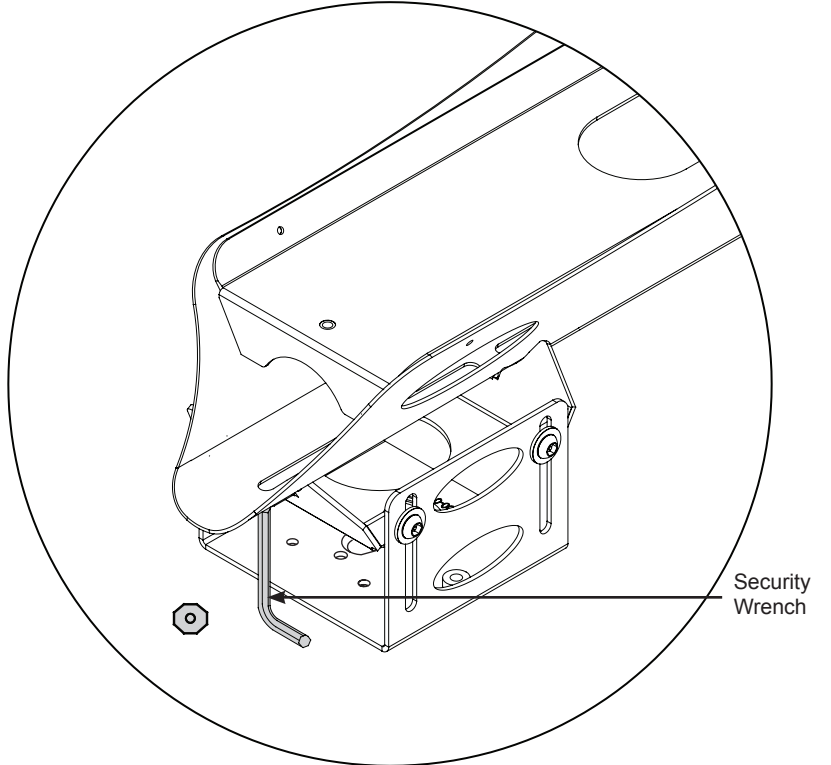

Do NOT overtighten these screws.

Continue to the "Utilizing the Storage Feature" section.



Utilizing the Storage Feature

The storage feature may be used to store electronic components. There is an accessible door on each side of the storage enclosure. It may be securely held shut with the use of four (4) M5 x 8mm security head screws. It may be easiest to pre-wire all cables down the arm (or extension) at this time.

- 1 Open the storage door that is located on the side of the wall plate.
- 2 Place the electronic components inside the storage enclosure.
- 3 Make all electronic connections at this time.
- 4 Close the storage door and secure using two (2; 1 upper and 1 lower) M5 x 8mm security head screws. Tighten using a security wrench. Repeat this process for the other side as well.

Proceed to the “**Cable Management**” section.

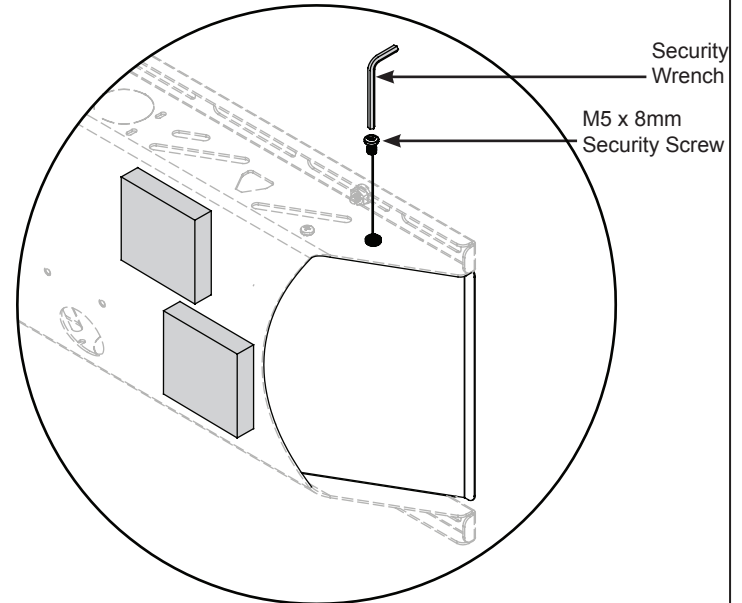
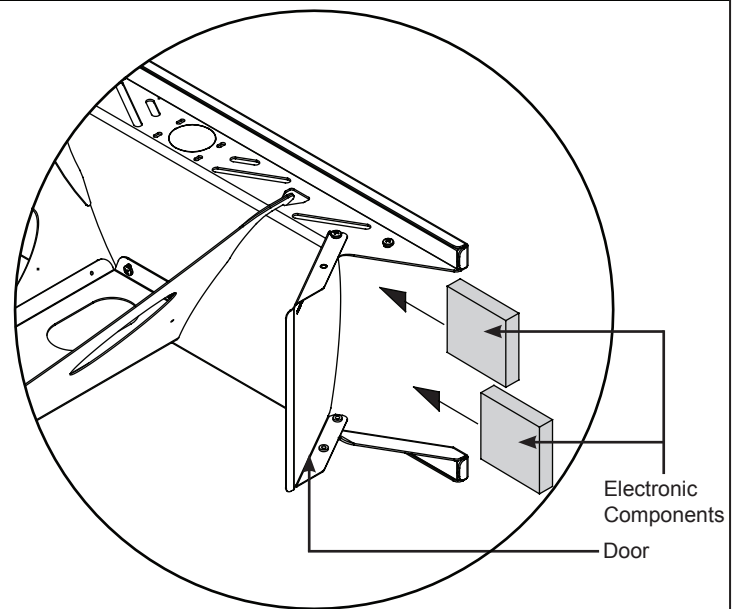



Cable Management

- 1 The cable access holes are located at the end of the short throw mount and on the wall plate.
- 2 Route the cables through one end of the UNI/UNIE and out the other end.
- 3 Attach the end cover with an M5 x 8mm security head screw.



You may direct the cables out the end of the UNI/UNIE. The end cover has a perforated tab to allow cables to pass out the end. Pliers must be used to bend the perforated tab. If the cables will not fit, the end cover may be removed by loosening and extracting the M5 x 8mm security screw.

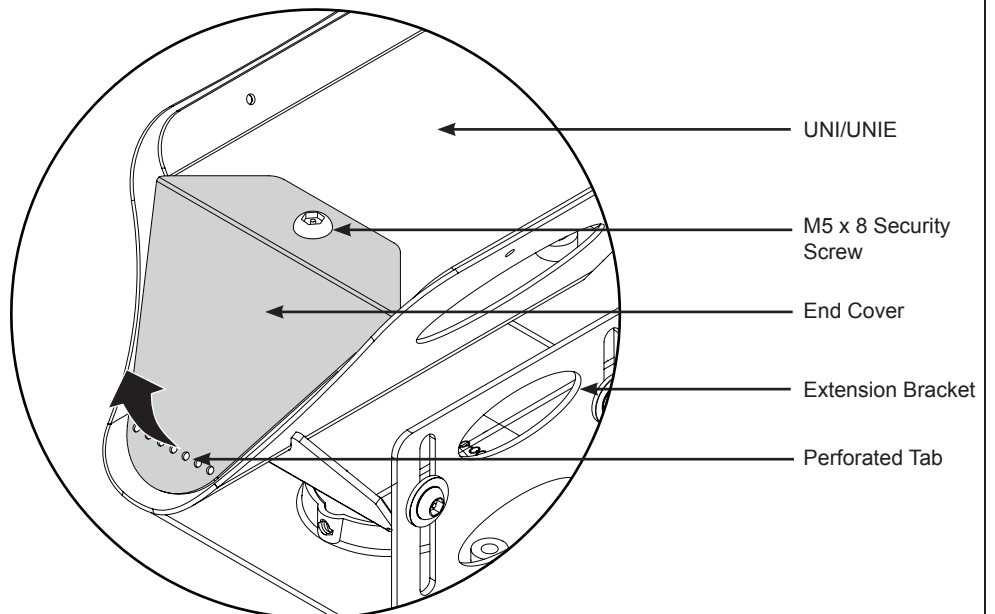
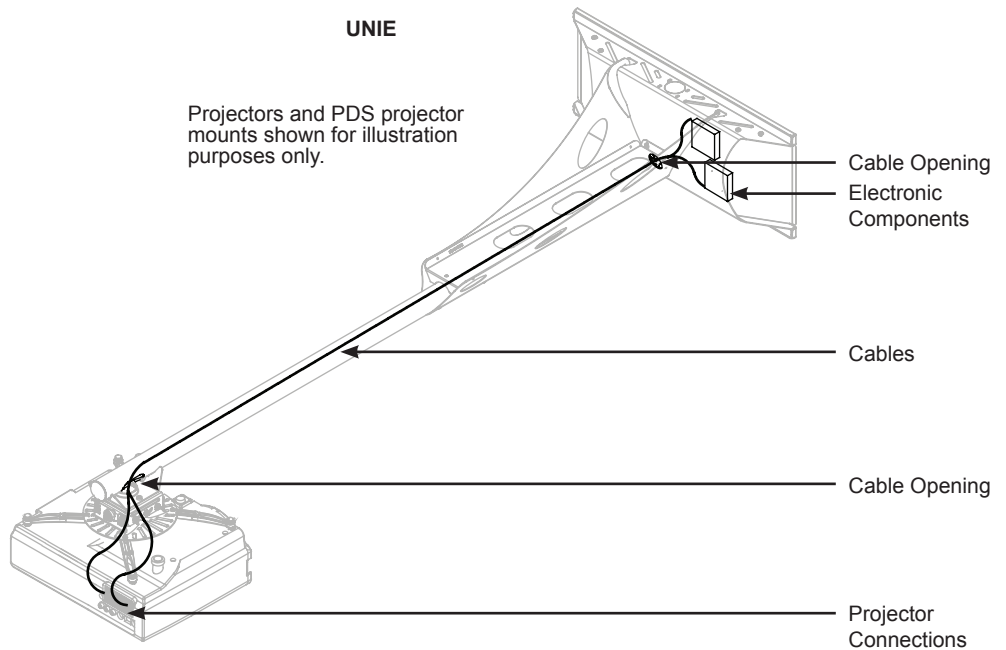
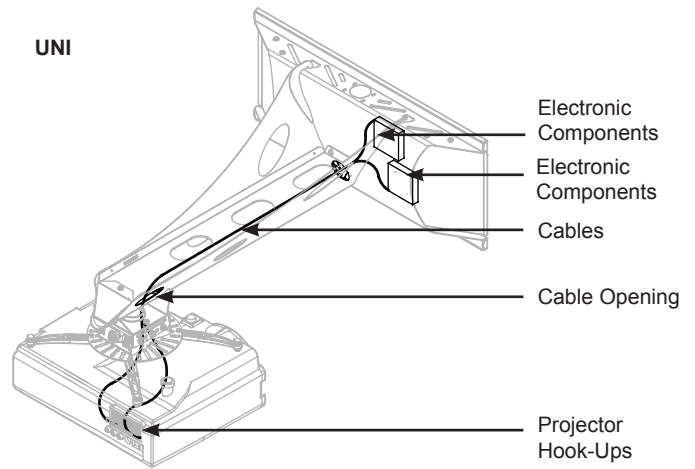



Technical Specifications

All measurements are in inches(mm).

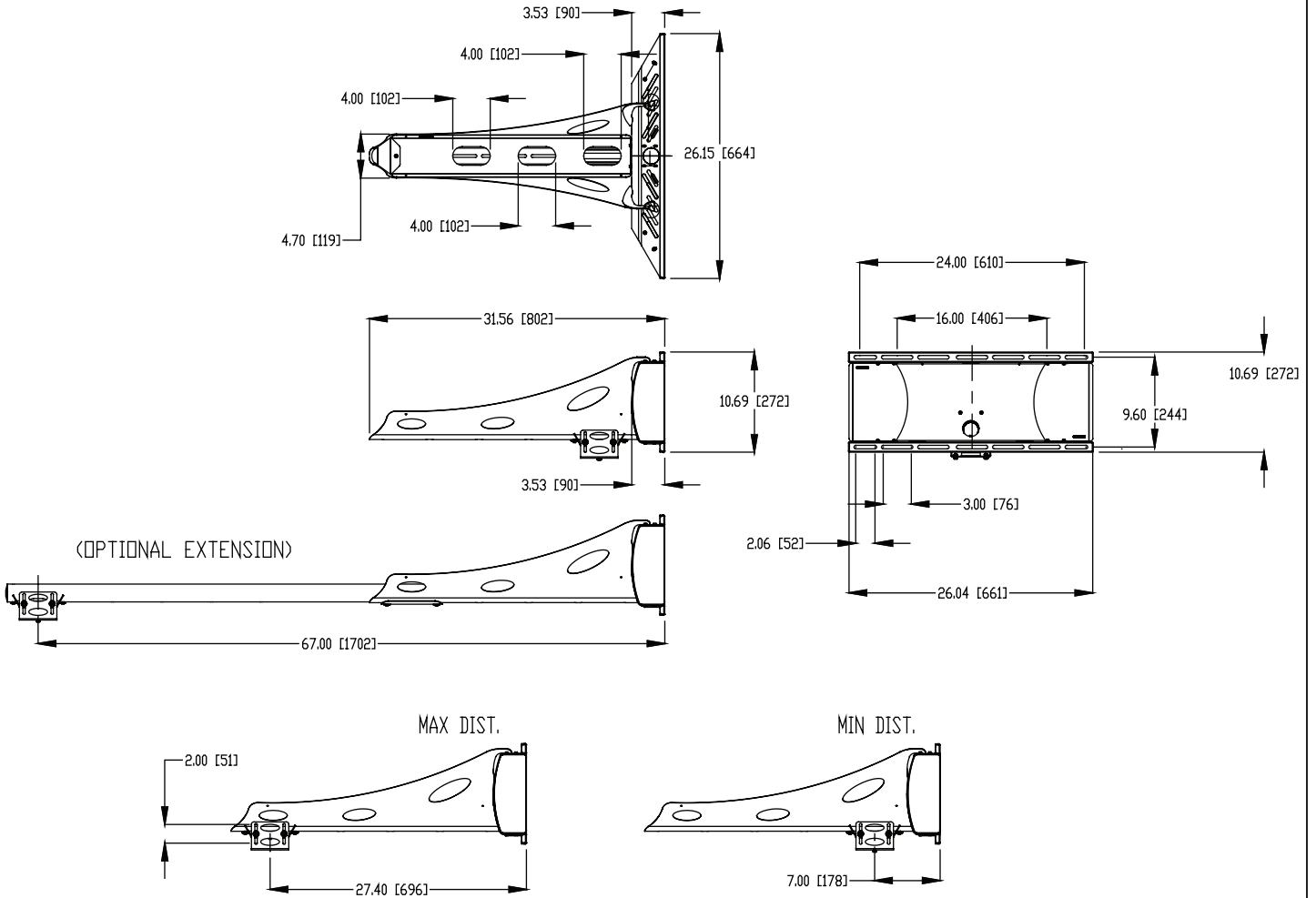



Warranty

PREMIER MOUNTS LIMITED LIFETIME WARRANTY

What and Who is Covered by this Limited Warranty and for How Long

Premier Mounts warrants this product to be free from defects in material and workmanship for the lifetime of the original owner of this product. The limited warranty is valid only for the original purchaser of the product.

What Premier Mounts Will Do

At the sole option of Premier Mounts, Premier Mounts will repair or replace any product or product part that is defective. If Premier Mounts chooses to replace a defective product or part, a replacement product or part will be shipped to you at no charge, but you must pay any labor costs.

What is Not Covered; Limitations

PREMIER MOUNTS DISCLAIMS ANY LIABILITY FOR DAMAGE TO MOUNTS, ADAPTERS, DISPLAYS, PROJECTORS, OTHER PROPERTY, OR PERSONAL INJURY RESULTING, IN WHOLE OR IN PART, FROM IMPROPER INSTALLATION, MODIFICATION, USE OR MISUSE OF ITS PRODUCTS.

PREMIER MOUNTS DISCLAIMS ALL OTHER WARRANTIES, EXPRESS OR IMPLIED, INCLUDING WARRANTIES OF MERCHANTABILITY AND FITNESS FOR A PARTICULAR PURPOSE. PREMIER MOUNTS IS NOT RESPONSIBLE FOR INCIDENTAL OR CONSEQUENTIAL DAMAGES, INCLUDING BUT NOT LIMITED TO, INABILITY TO USE ITS PRODUCTS OR LABOR COSTS FOR REMOVING AND REPLACING DEFECTIVE PRODUCTS OR PARTS. SOME STATES DO NOT ALLOW THE EXCLUSION OR LIMITATION OF INCIDENTAL OR CONSEQUENTIAL DAMAGES, SO THE ABOVE LIMITATION OR EXCLUSION MAY NOT APPLY TO YOU.

What Customers Must Do for Limited Warranty Service

If you discover a problem that you think may be covered by the warranty you MUST REPORT it in writing to the address below within thirty (30) days. Proof of purchase (an original sales receipt) from the original consumer purchaser must accompany all warranty claims. Warranty claims must also include a description of the problem, the purchaser's name, address, and telephone number. General inquiries can be addressed to Premier Mounts Customer Service at 1-800-368-9700. Warranty claims will not be accepted over the phone or by fax.

Premier Mounts
Attn: Warranty Claim
3130 East Miraloma Ave.
Anaheim, CA 92806

How State Law Applies

THIS WARRANTY GIVES YOU SPECIFIC LEGAL RIGHTS, AND YOU MAY ALSO HAVE OTHER RIGHTS WHICH VARY FROM STATE TO STATE.

Disclaimer

Premier Mounts intends to make this manual accurate and complete. However, Premier Mounts makes no claim that the information contained herein covers all details, conditions or variations, nor does it provide for every possible contingency in connection with the installation or use of this product. The information contained in this document is subject to change without notice or obligation of any kind. Premier Mounts makes no representation of warranty, expressed or implied, regarding the information contained herein. Premier Mounts assumes no responsibility for accuracy, completeness or sufficiency of the information contained in this document.