

Single Stud Tilt and Pivot Mount for Flat Panels

Model: **PTM, PTM-B**

Weight Capacity: 50 lb / 22.7 kg.

Features

- 1** Elliptical back plate design combines sturdiness with an aesthetically pleasing design
 - 2** 360° screen rotation
 - 3** Radial Glide™ provides 15° of smooth adjustment in any direction
- OSHPD and DSA Approved (OPA-1680)
 - Set screws secure flat-panel to wall plate

The PTM Single Stud Tilt and Pivot Mount holds flat panel displays up to 50 lb. The wall mount offers 15° of smooth adjustment with Radial Glide™ and comes with cable routing holes to route cables directly into the wall for a clean appearance. OSHPD approved and UL listed, it is available in silver (PTM) or black (PTM-B).



Fits VESA patterns of 75x75, 100x100, 200x100, or 200x200 mm



PTM available in silver, or in black as model PTM-B



Set screws secure flat-panel to the wall plate

VESA Tilt and Pivot Mount for Flat-panels

PTM, PTM-B



Specifications

Color PTM Silver PTM-B Black	Weight Capacity / Mount 50 lb. 22.7 kg	Mounting Pattern 75 x 75 mm (Min) - 200 x 200 mm (Max)	Total Weight Capacity 50 lb. 22.7 kg
Width x Height x Depth 3.94 - 8.88 x 9.5 x 2.84 in. 100 - 225 x 241 x 72 mm	Weight 6.44 lb. 2.9 kg	Warranty Lifetime	

Packaging

Width x Height x Depth 10 x 9.13 x 3.63 in. 254 x 232 x 92 mm	Contents Wall Mount (x1), UFP-280 Plate (x1), Universal Hardware Pack (x1)
---	--

Accessories

 <p>Protected Mounting Frame for iPads with VESA Mounting Pattern IPM-100</p>	 <p>VESA Adapter Plate 200 x 100 or 100 x 200 UFP-220</p>
---	---

Architectural Drawing

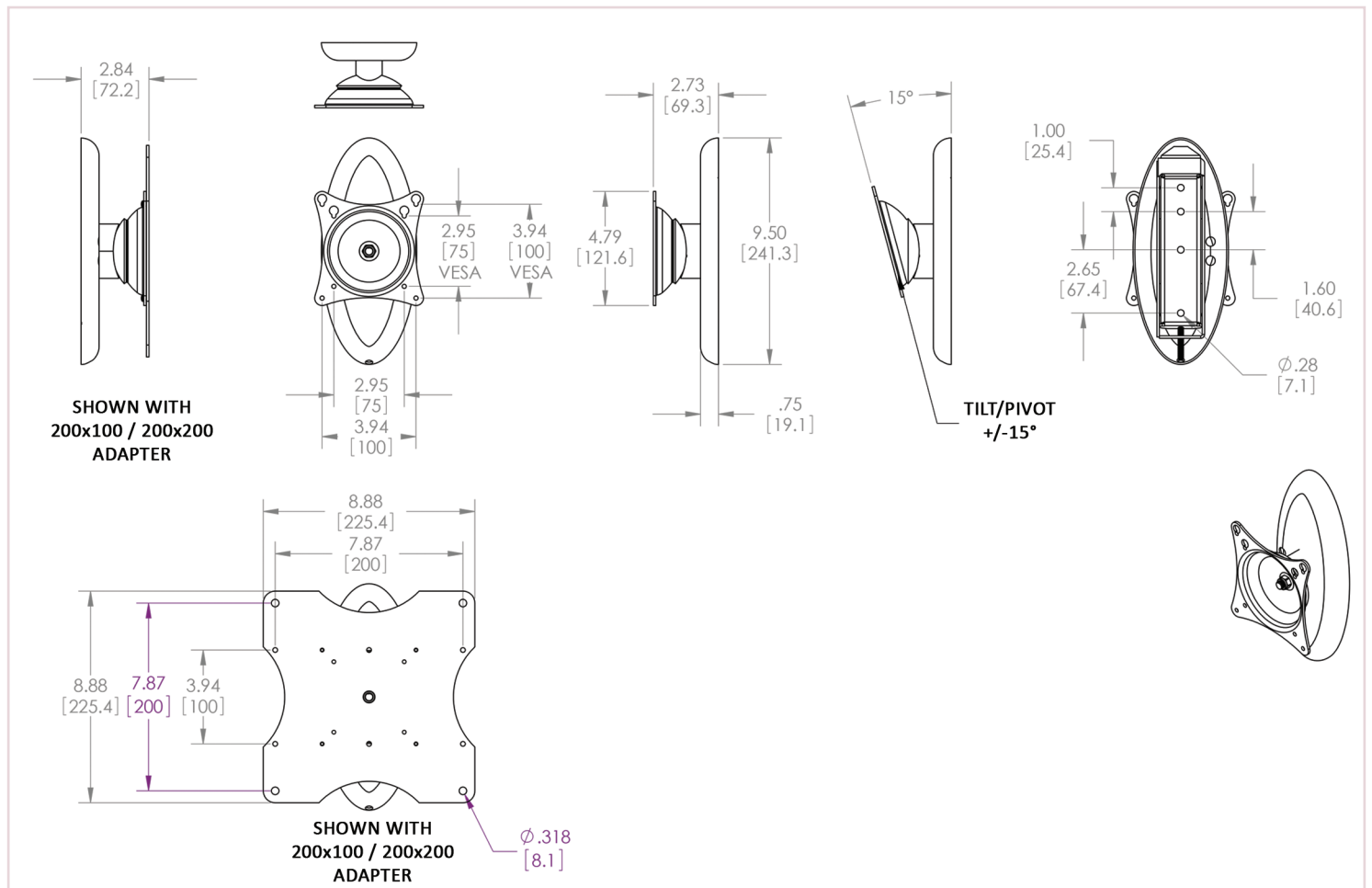

Specifications subject to change without notice

T: 800.368.9700 Int'l: +001.714.632.7100 | www.mounts.com | 1321 S. State College Blvd., Fullerton, CA 92831 USA



Visit mounts.com to see the complete line of AV solutions from Premier Mounts, including flat-panel mounts, projector mounts, carts/stands, and a full assortment of accessories.
© 2015 Premier Mounts. All rights reserved. Rev. 01-14-06

Rev. 02-15-09