



INSTRUCTIONS D'ASSEMBLAGE
ASSEMBLY INSTRUCTIONS

MONARCH
SPECIALTIES INC.

I 2766

ETAGERE -
69" H / TAUPE FONCE ECHELLE ET / TIROIR DE
RANGEMENT

BOOKCASE -
69" H / DARK TAUPE LADDER W / STORAGE DRAWER



POUR DE L'ASSISTANCE OU POUR COMMANDER
DES PIÈCES CONTACTEZ NOTRE DÉPARTEMENT
DE SERVICE À LA CLIENTÈLE.

FOR ASSISTANCE OR TO ORDER PARTS
CONTACT OUR CUSTOMER SERVICE DEPARTMENT

WWW.MONARCHSERVICE.COM

LISTE DES PIÈCES
PARTS LIST

| PIÈCE / PART # | IMAGE | DESCRIPTION | QTY / QTÉ |
|----------------|---|--|-----------|
| 1 |  | FRONT FACING LEFT LEG PATTE AVANT GAUCHE | 1 |
| 2 |  | FRONT FACING LEFT LEG PATTE AVANT GAUCHE | 1 |
| 3 |  | FRONT FACING RIGHT LEG PATTE AVANT DROITE | 1 |
| 4 |  | FRONT FACING RIGHT LEG PATTE AVANT DROITE | 1 |
| 5 |  | CROSSBAR BARRE TRANSVERSALE | 3 |

LISTE DES PIÈCES
PARTS LIST

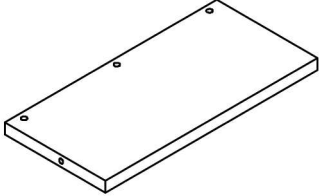
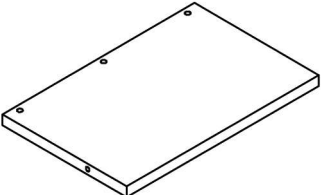
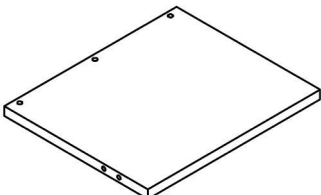
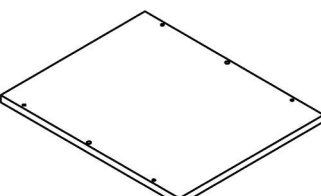
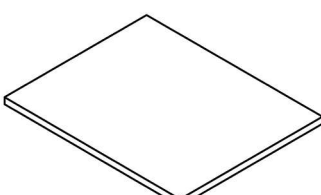
| PIÈCE / PART # | IMAGE | DESCRIPTION | QTY / QTÉ |
|----------------|---|------------------------------------|-----------|
| 6 |  | TOP SHELF ÉTAGÈRE SUPÉRIEURE | 1 |
| 7 |  | SHELF PANEL PANNEAU DE TABLETTE | 1 |
| 8 |  | BOTTOM SHELF ÉTAGÈRE DU BAS | 1 |
| 9 |  | BOTTOM PANEL PANNEAU DU BAS | 1 |
| 10 |  | TOP PANEL PANNEAU DE SURFACE | 1 |

LISTE DES PIÈCES
PARTS LIST

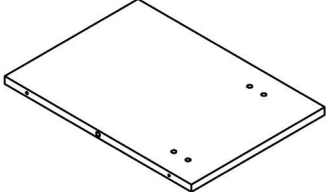
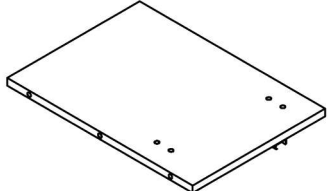
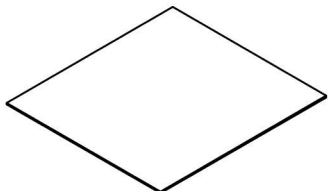
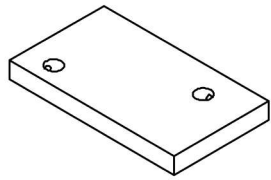
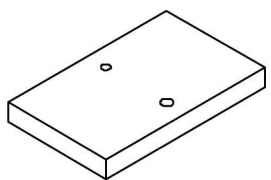
| PIÈCE / PART # | IMAGE | DESCRIPTION | QTY / QTÉ |
|----------------|---|--|-----------|
| 11 |  | FRONT FACING LEFT SIDE PANEL PANNEAU DE CÔTÉ GAUCHE | 1 |
| 12 |  | FRONT FACING RIGHT SIDE PANEL PANNEAU DE CÔTÉ AVANT DROIT | 1 |
| 13 |  | BACK PANEL PANNEAU ARRIÈRE | 1 |
| 14 |  | CROSSBAR BARRE TRANSVERSALE | 1 |
| 15 |  | CROSSBAR BARRE TRANSVERSALE | 1 |

LISTE DES PIÈCES
PARTS LIST

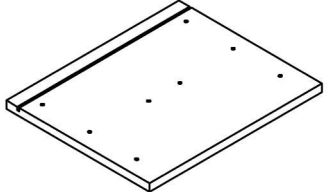
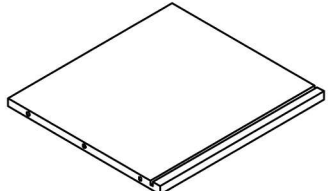
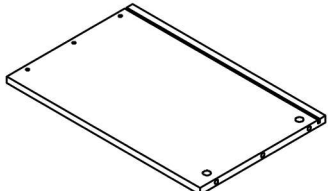
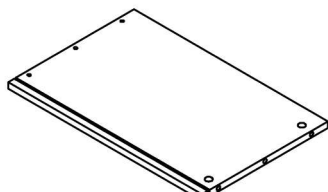
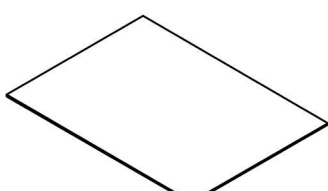
| PIÈCE / PART # | IMAGE | DESCRIPTION | QTY / QTÉ |
|----------------|---|--|-----------|
| 16 |  | DRAWER FRONT PANEL PANNEAU AVANT TIROIR | 1 |
| 17 |  | DRAWER BACK PANEL PANNEAU ARRIÈRE TIROIR | 1 |
| 18 |  | DRAWER SIDE PANEL PANNEAU DE CÔTÉ TIROIR | 1 |
| 19 |  | DRAWER SIDE PANEL PANNEAU DE CÔTÉ TIROIR | 1 |
| 20 |  | DRAWER BOTTOM PANEL PANNEAU DU BAS TIROIR | 1 |

LISTE DES PIÈCES DE MONTAGE
HARDWARE LIST

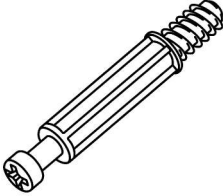
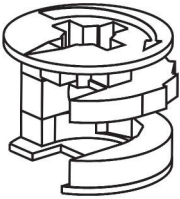
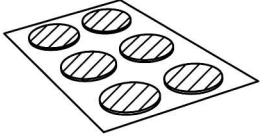
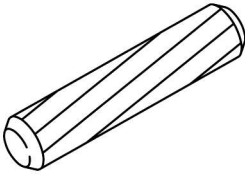
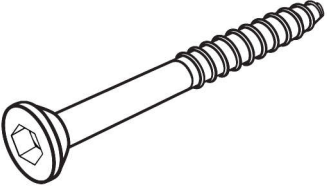
| PIÈCE / PART # | IMAGE | DESCRIPTION | QTY / QTÉ |
|----------------|---|--|-----------|
| A |  | CAM LOCK SCREW - 1 1/8" VIS CAM LOCK - 1 1/8" | 8 |
| B |  | CAM LOCK CONNECTOR - Ø5/8" ÉCROU CAM LOCK - Ø5/8" | 8 |
| C |  | FINISHING STICKER - Ø7/8" COLLANT DE FINITION - Ø7/8" | 8 |
| D |  | WOOD DOWEL - Ø3/8" X 1" GOUJON DE BOIS - Ø3/8" X 1" | 15 |
| E |  | ASSEMBLING SCREW - 2 1/8" VIS D'ASSEMBLAGE - 2 1/8" | 8 |

LISTE DES PIÈCES DE MONTAGE
HARDWARE LIST

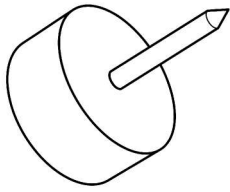
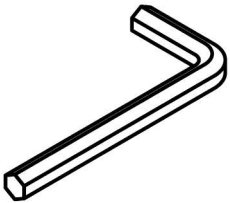
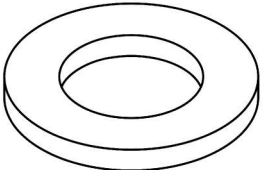
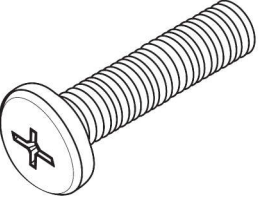
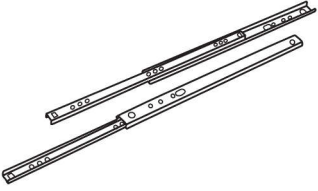
| PIÈCE / PART # | IMAGE | DESCRIPTION | QTY / QTÉ |
|----------------|---|---|-----------|
| F |  | FLOOR PROTECTOR - Ø5/8" PROTECTEUR DE PLANCHER - Ø5/8" | 5 |
| G |  | HEX KEY CLÉ HEXAGONALE | 1 |
| H |  | METAL WASHER - Ø5/8" RONDELLE DE MÉTAL - Ø5/8" | 8 |
| I |  | ASSEMBLING BOLT - 1" BOULON D'ASSEMBLAGE - 1" | 8 |
| J |  | METAL DRAWER SLIDE - 16" COULISSE DE MÉTAL - 16" | 1 |

LISTE DES PIÈCES DE MONTAGE
HARDWARE LIST

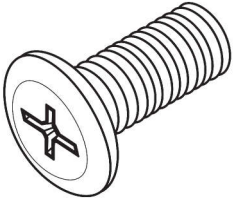
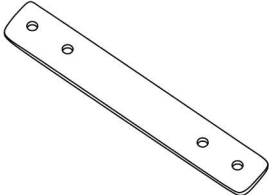
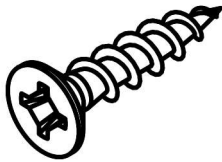
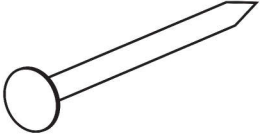
| PIÈCE / PART # | IMAGE | DESCRIPTION | QTY / QTÉ |
|----------------|---|--|-----------|
| K |  | ASSEMBLING SCREW - Ø1/8" X 1/2" VIS D'ASSEMBLAGE - Ø1/8" X 1/2" | 12 |
| L |  | ASSEMBLING BOLT - 1/2" BOULON D'ASSEMBLAGE - 1/2" | 8 |
| M |  | SUPPORT PLATE - 6 3/4" X 1" PLAQUE DE SUPPORT - 6 3/4" X 1" | 2 |
| N |  | ASSEMBLING SCREW - Ø1/8" X 1 3/8" VIS D'ASSEMBLAGE - Ø1/8" X 1 3/8" | 4 |
| O |  | NAIL CLOU | 16 |

LISTE DES PIÈCES DE MONTAGE
HARDWARE LIST

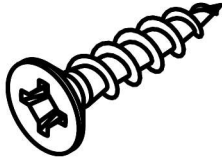
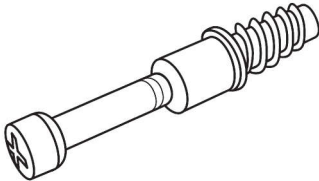
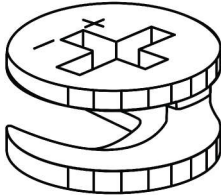
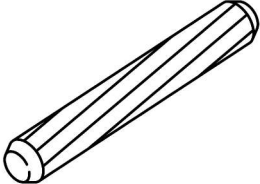
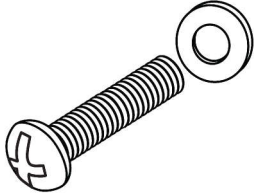
| PIÈCE / PART # | IMAGE | DESCRIPTION | QTY / QTÉ |
|----------------|---|--|-----------|
| P |  | ASSEMBLING SCREW - Ø1/8" X 1 1/8" VIS D'ASSEMBLAGE - Ø1/8" X 1 1/8" | 6 |
| Q |  | CAM LOCK SCREW - 3/4" VIS CAM LOCK - 3/4" | 4 |
| R |  | CAM LOCK CONNECTOR - Ø1/2" ÉCROU CAM LOCK - Ø1/2" | 4 |
| S |  | WOOD DOWEL - Ø1/4" X 1 1/8" GOUJON DE BOIS - Ø1/4" X 1 1/8" | 2 |
| T |  | BOLT SET - Ø1/8" X 7/8" ENSEMBLE DE BOULON - Ø1/8" X 7/8" | 2 |

LISTE DES PIÈCES DE MONTAGE
HARDWARE LIST

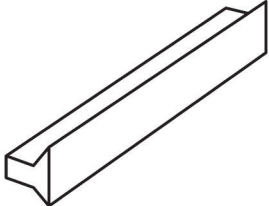
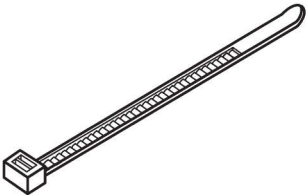
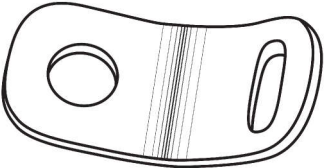
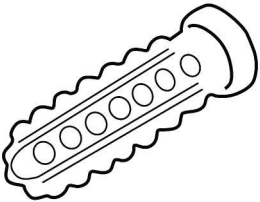
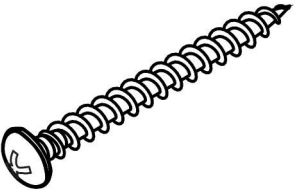
| PIÈCE / PART # | IMAGE | DESCRIPTION | QTY / QTÉ |
|----------------|---|--|-----------|
| U |  | HANDLE POIGNÉE | 1 |
| V |  | ZIP TIE - 7 3/4" X 1/8" ATTACHE AUTOBLOQUANTE - 7 3/4" X 1/8" | 1 |
| W |  | METAL BRACKET - 1/2" X 1/2" SUPPORT EN MÉTAL - 1/2" X 1/2" | 2 |
| X |  | ANCHOR - Ø3/8" X 1 1/2" ANCRE - Ø3/8" X 1 1/2" | 1 |
| Y |  | ASSEMBLING SCREW - Ø1/8" X 1 1/2" VIS D'ASSEMBLAGE - Ø1/8" X 1 1/2" | 1 |

LISTE DES PIÈCES DE MONTAGE
HARDWARE LIST

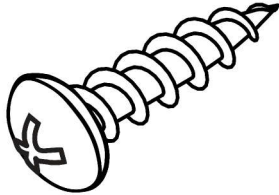
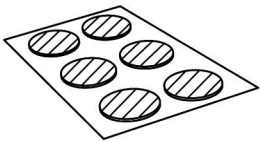
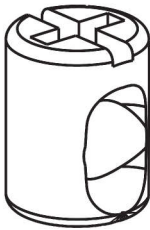
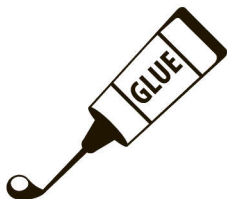
| PIÈCE / PART # | IMAGE | DESCRIPTION | QTY / QTÉ |
|----------------|---|--|-----------|
| Z |  | ASSEMBLING SCREW - Ø1/8" X 1" VIS D'ASSEMBLAGE - Ø1/8" X 1" | 1 |
| Z1 |  | FINISHING STICKER - Ø1/2" COLLANT DE FINITION - Ø1/2" | 8 |
| Z2 |  | BARREL NUT - Ø3/8" X 1/2" ÉCROU DE CANON - Ø3/8" X 1/2" | 8 |
| Z3 |  | GLUE - 10G COLLE - 10G | 1 |

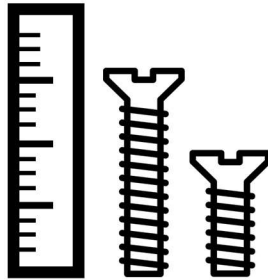

OUTIL DE VÉRIFICATION DE DIMENSIONS DES PIÈCES
HARDWARE DIMENSIONS VERIFICATION TOOL

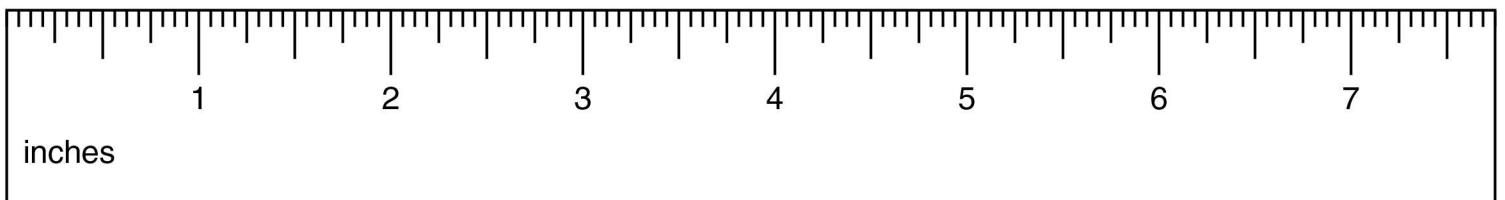

ÉTAPE / STEP 1

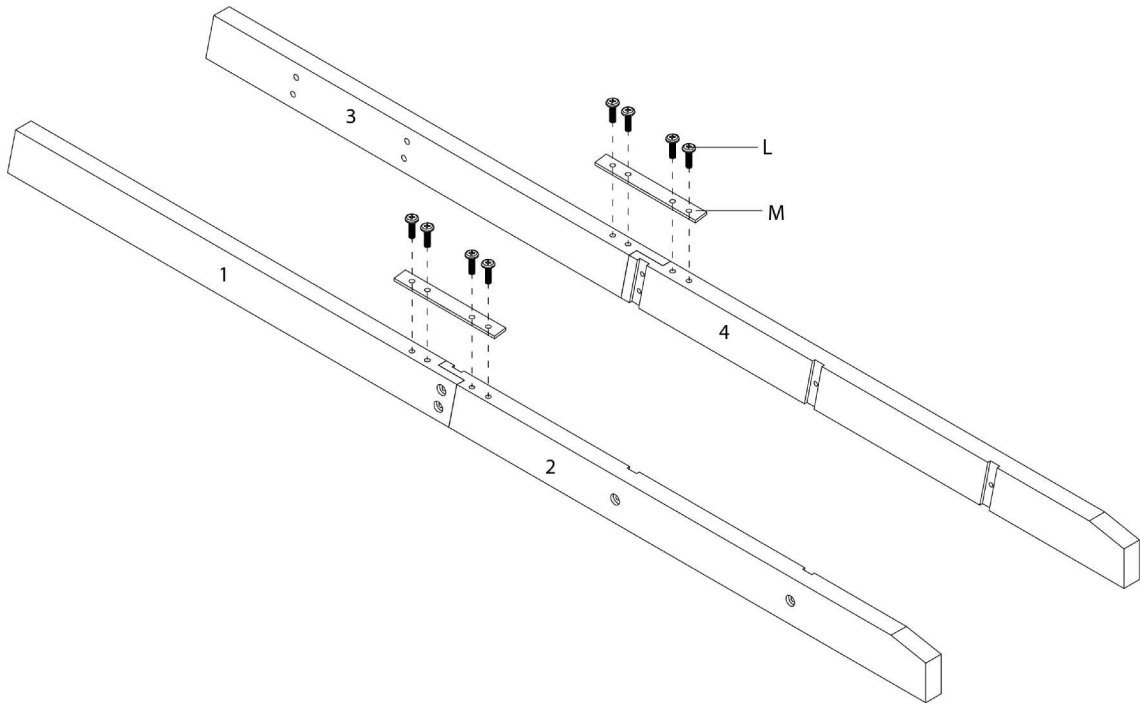

ÉTAPE / STEP 2

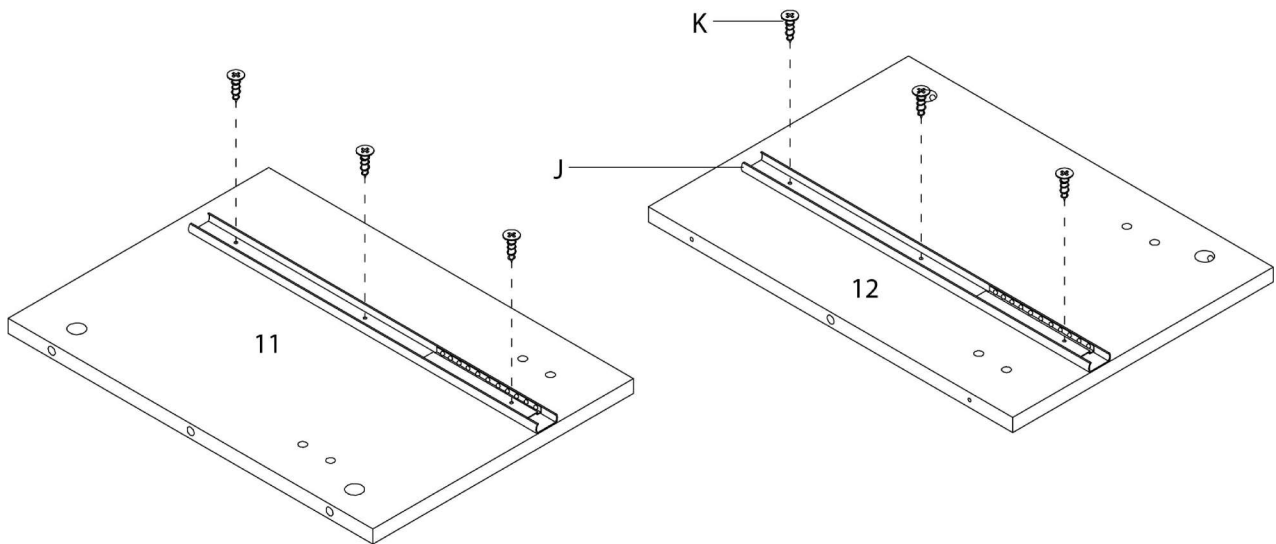

ÉTAPE / STEP 3

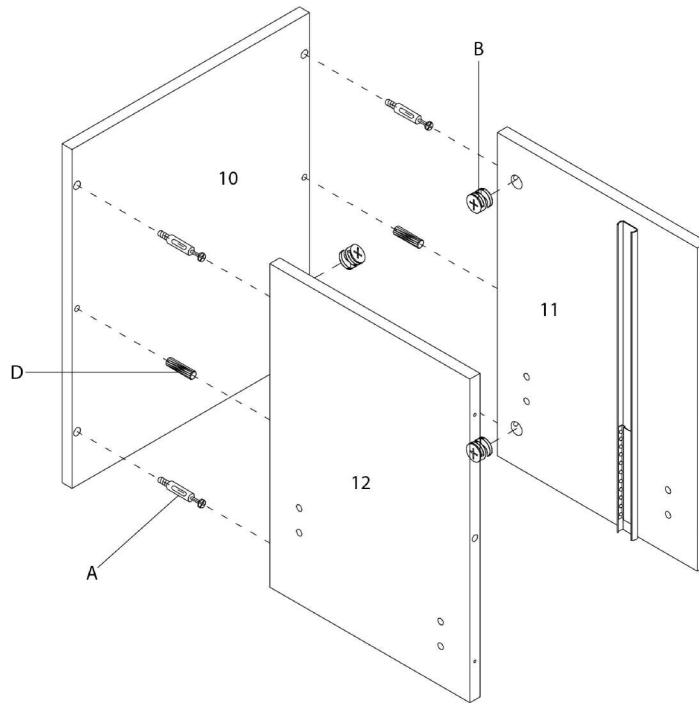

ÉTAPE / STEP 4

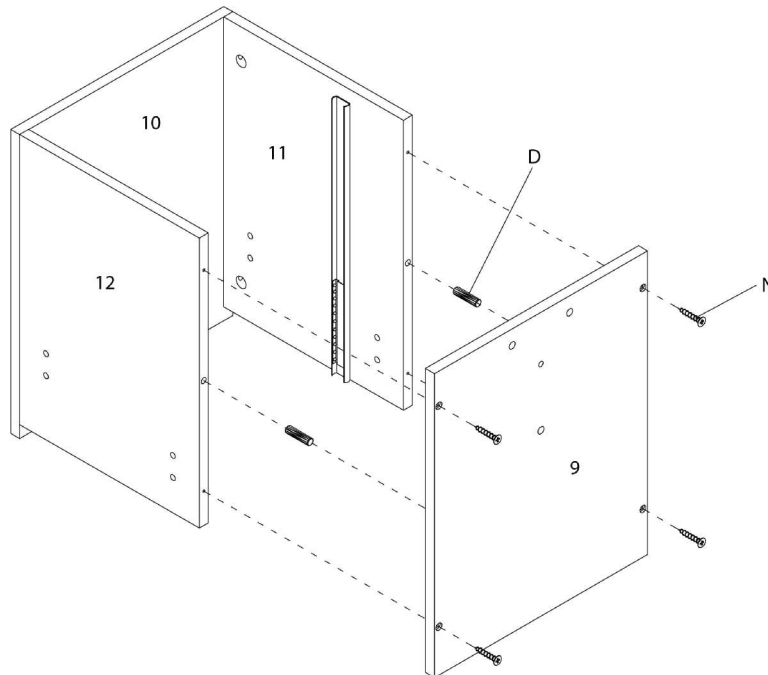

ÉTAPE / STEP 5

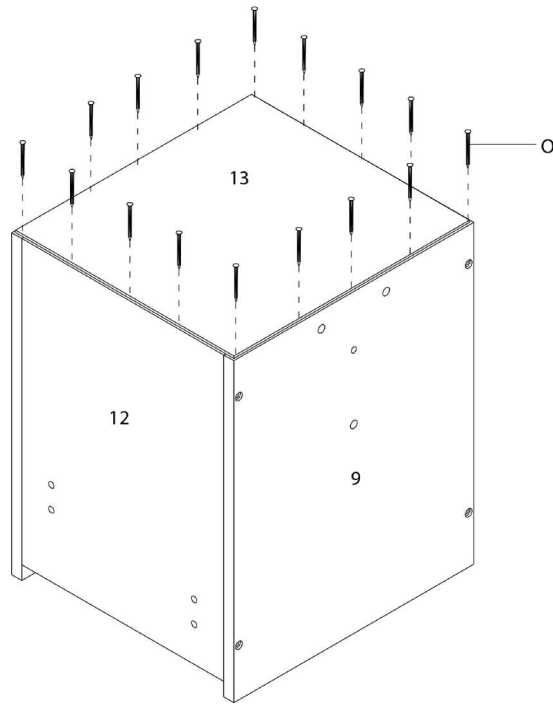

ÉTAPE / STEP 6

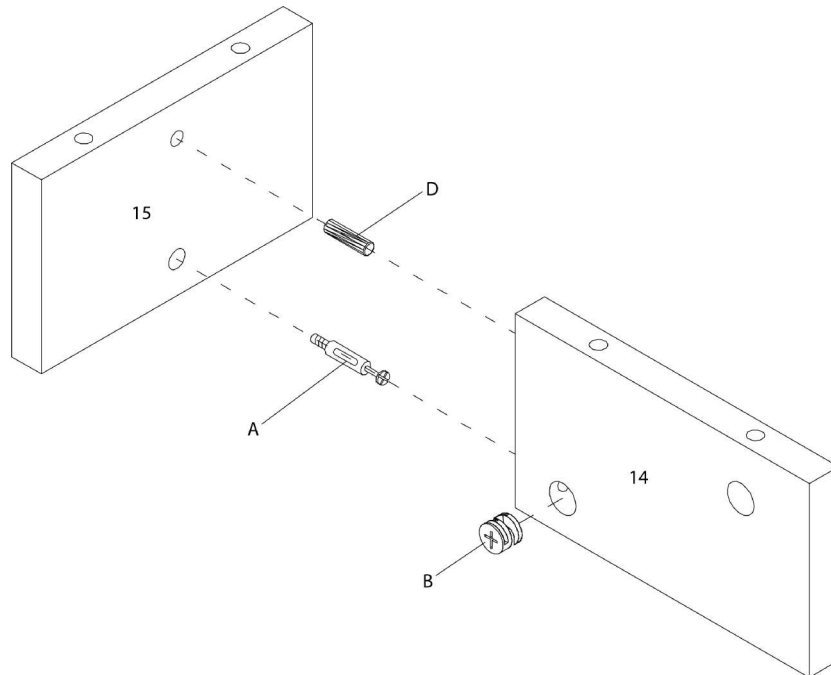

ÉTAPE / STEP 7

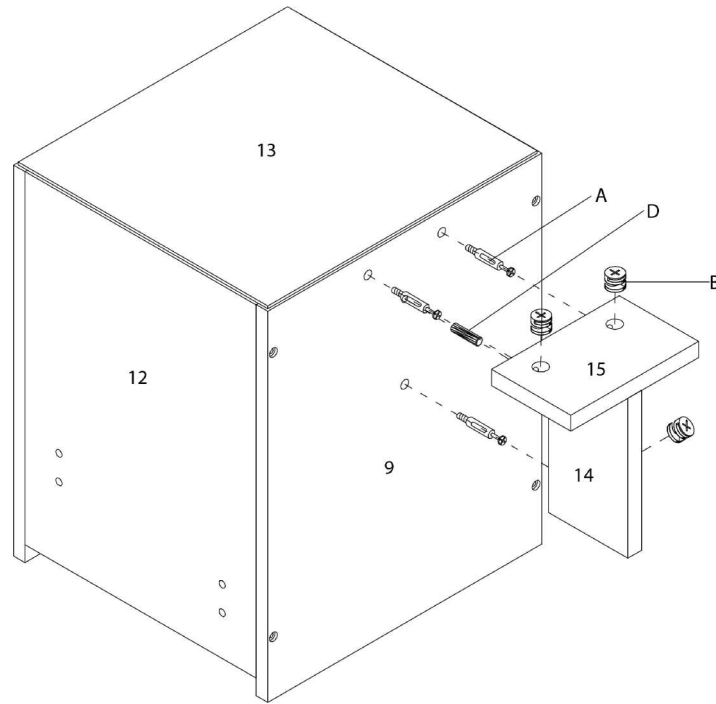

ÉTAPE / STEP 8

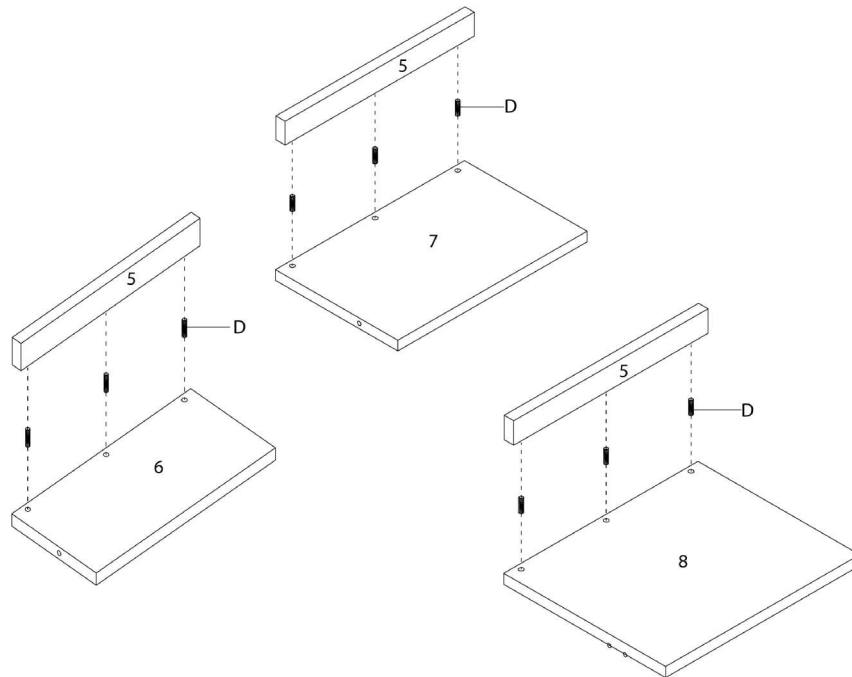

ÉTAPE / STEP 9

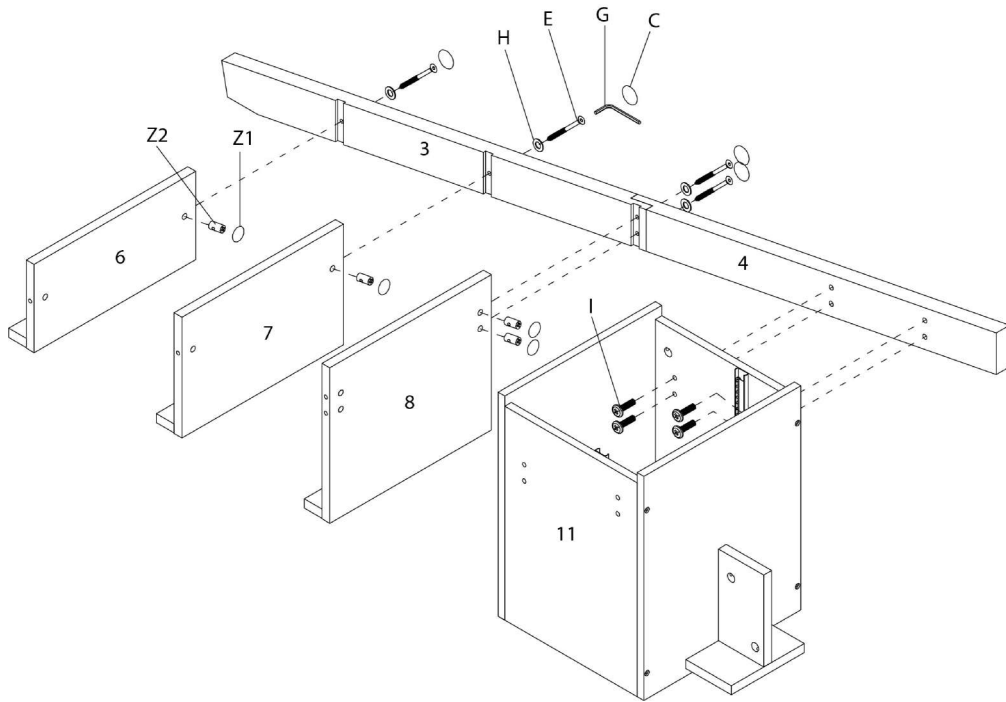

ÉTAPE / STEP 10

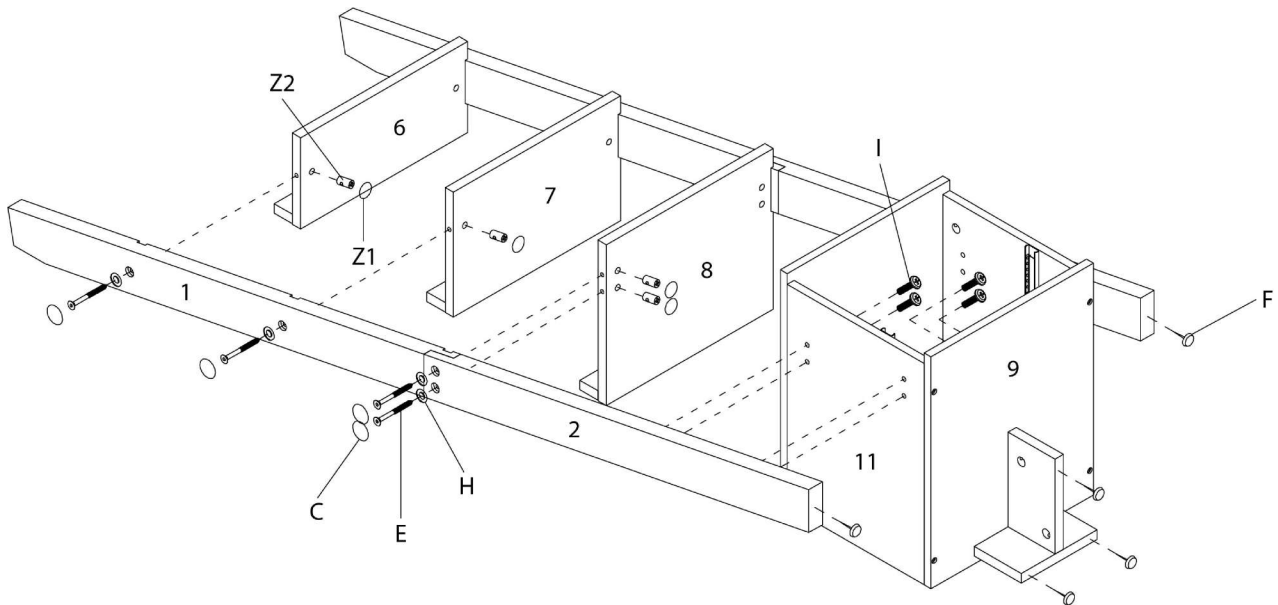

ÉTAPE / STEP 11

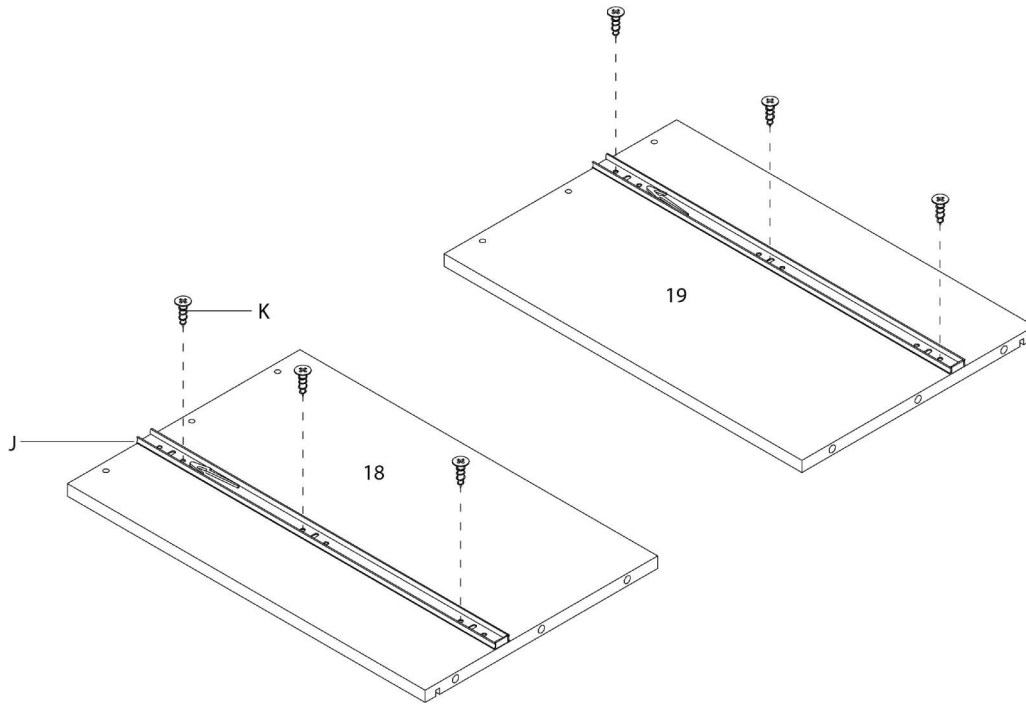

ÉTAPE / STEP 12

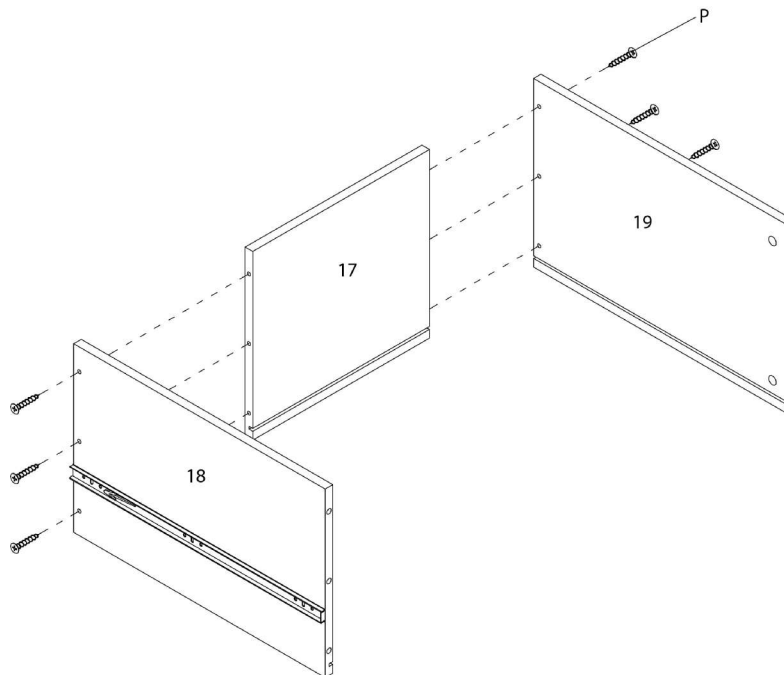

ÉTAPE / STEP 13

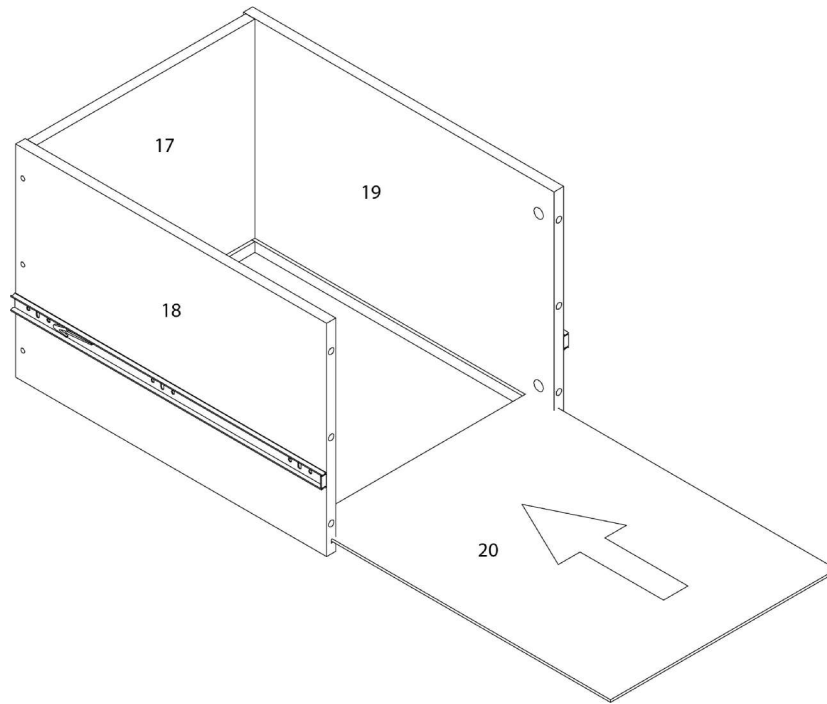

ÉTAPE / STEP 14

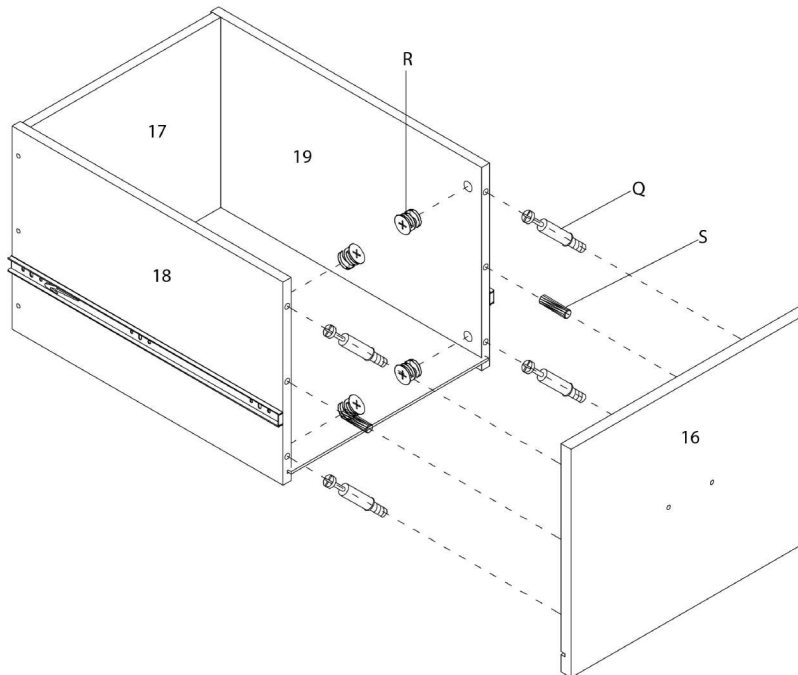

ÉTAPE / STEP 15

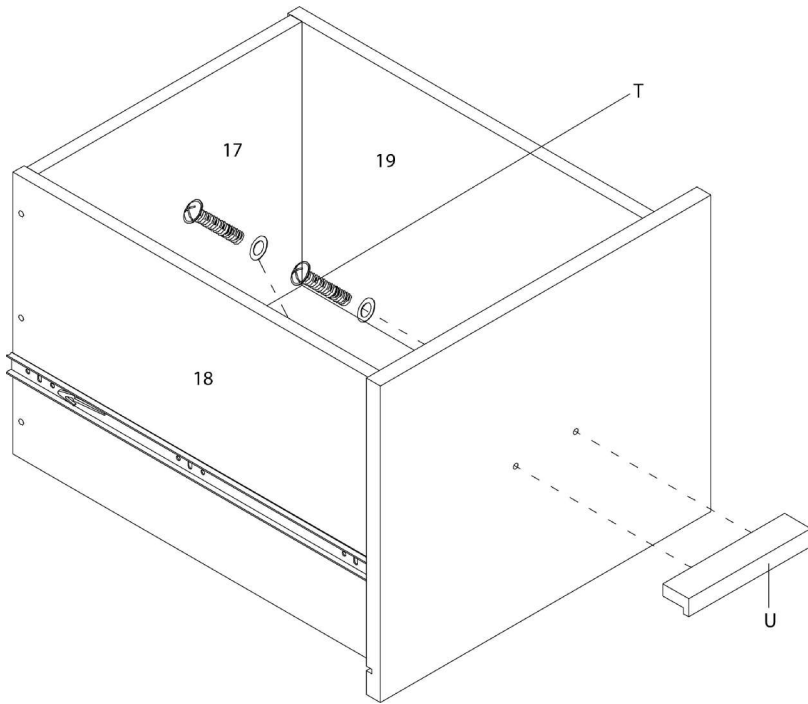

ÉTAPE / STEP 16

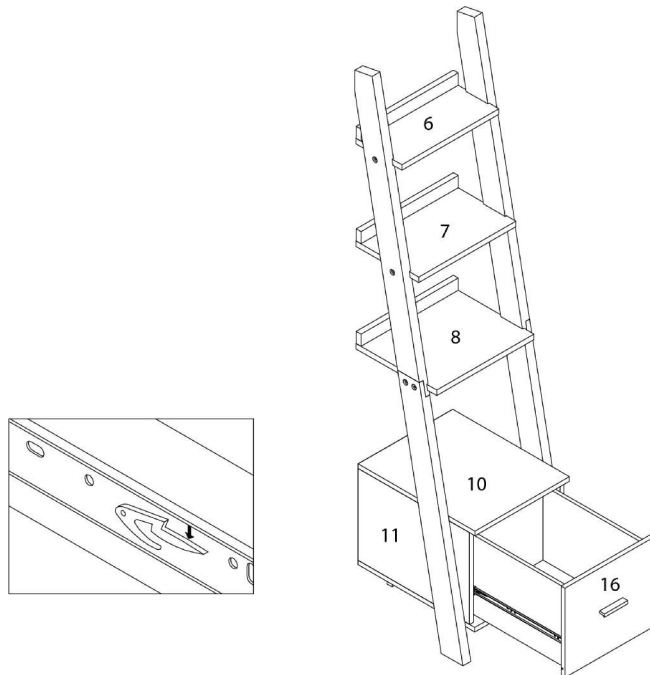

ÉTAPE / STEP 17

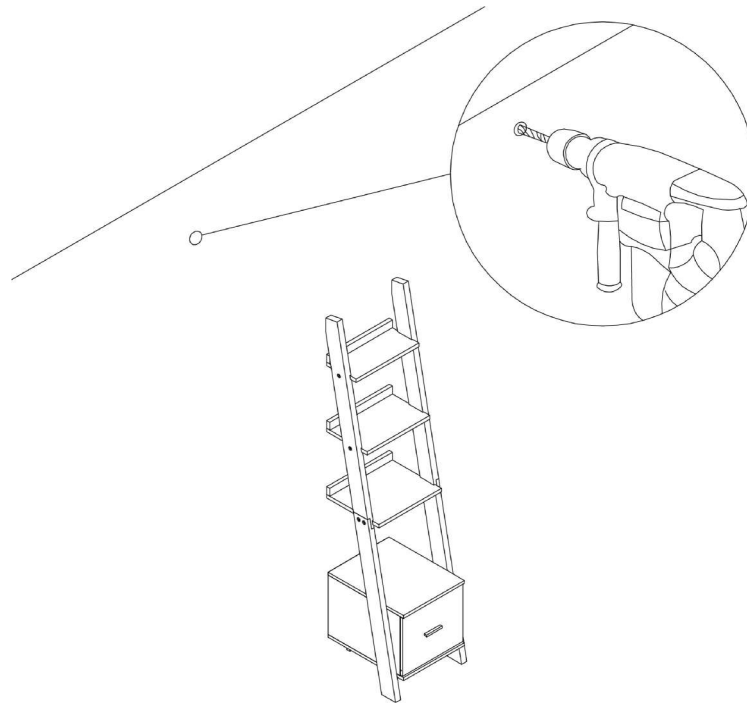

ÉTAPE / STEP 18

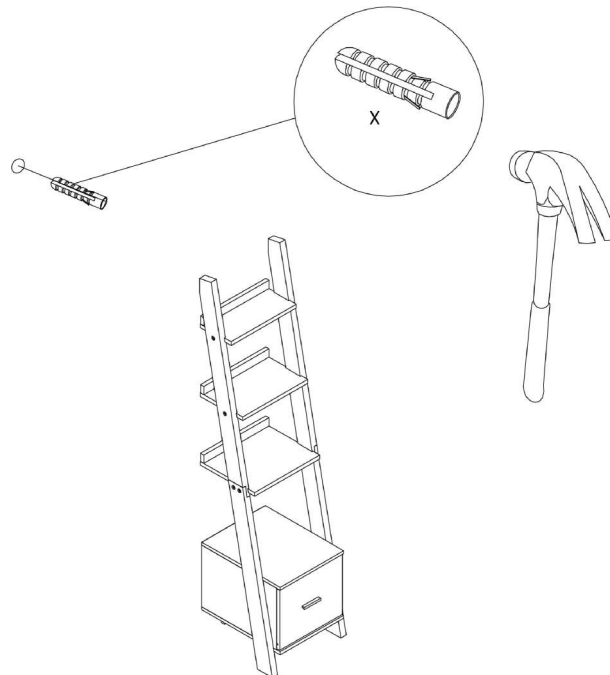

ÉTAPE / STEP 19

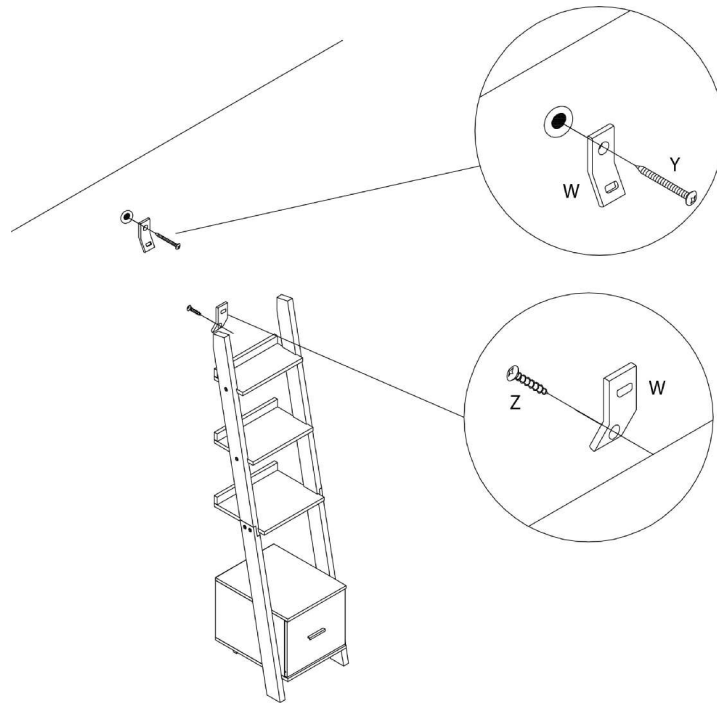

ÉTAPE / STEP 20

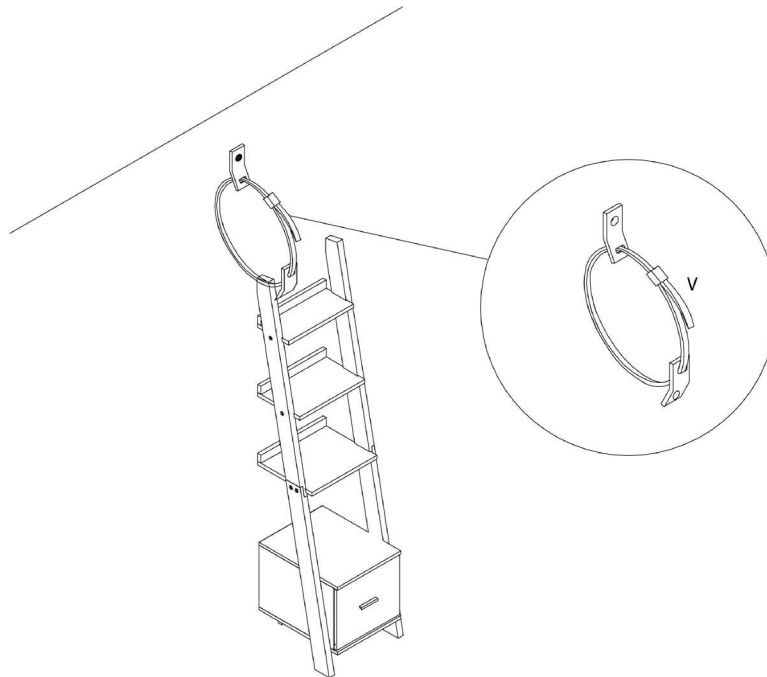

ÉTAPE / STEP 21

