



Chrysler Multikit 2007-up*

*Visit MetraOnline.com for up-to-date vehicle specific applications.

KIT FEATURES

- ISO DDIN radio provision
- Two sizes of trim panels accommodate “long nose” or “short nose” DDIN radios
- Textured

KIT COMPONENTS

- A) “Long nose” (wide) DDIN trim panels
- B) “Short nose” (narrow) DDIN trim panels
- C) ISO DDIN radio brackets
- D) (4) #8 x 1/4” Phillips screws

A

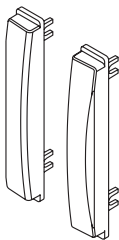

B

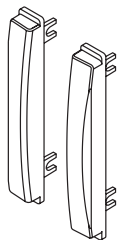

C

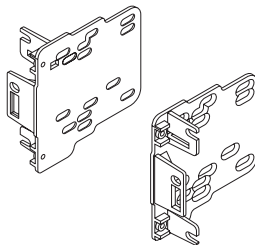

D



TABLE OF CONTENTS

See page 2

WIRING & ANTENNA CONNECTIONS (sold separately)

Wiring Harness: XSVI-6522-NAV • CHT0-03

Antenna Adapter: 40-EU10

TOOLS REQUIRED

- Panel removal tool
- Phillips screwdriver
- Socket set
- Cutting tool (*sub-dash modifications required for most applications*)

CAUTION! All accessories, switches, climate controls panels, and especially air bag indicator lights must be connected before cycling the ignition. Also, do not remove the factory radio with the key in the on position, or while the vehicle is running.

APPLICATIONS

Chrysler

200	2011-2014
300/300C	2008-2010
Aspen	2008-2009
Sebring	2007-2010
Town and Country	2008-2017

Dodge

Avenger	2008-2014
Caliber	2009-2012
Challenger	2008-2014
Charger	2008-2010
Dakota	2008-2011
Durango	2008-2009
Grand Caravan	2008-up
Journey**	2009-2010
Magnum	2008-2009
Nitro	2007-2011
Ram 1500	2009-2011
Ram 2500/3500	2010-2011
Ram Chassis Cab	2011

Jeep

Compass	2009-2017.5
Commander	2008-2010
Grand Cherokee	2008-2010
Liberty	2008-2012
Patriot	2009-2017
Wrangler**	2007-up

Mitsubishi

Raider	2008-2009
--------------	-----------

Ram

1500/2500/3500	2012
Chassis Cab 3500/4500/5500	2012
C/V Tradesman	2012-2015

VW

Routan	2009-2013
--------------	-----------

***(modifications to radio cavity required)*

TABLE OF CONTENTS

Dash Disassembly

- Chrysler Aspen 2008-2009/
Dodge Durango 2008-2009 3
- Chrysler Sebring 2007-2010 3
- Chrysler Town and Country 2008-2010,
Dodge Grand Caravan 2008-2010..... 4
- Chrysler Town and Country 2011-2017,
Dodge Grand Caravan 2011-up,
Volkswagen Routan 2009-2013..... 5
- Chrysler 200 2011-2014 5
- Chrysler 300/300C 2008-2010,
Dodge Magnum 2008-2009/
Charger 2008-2010 6
- Dodge Avenger 2008-2014 6
- Dodge Nitro 2007-2011,
Jeep Liberty 2008-2012 7
- Dodge Journey 2009-2010** 8
- Dodge Caliber 2009-2012/Challenger 2008-2014,
Jeep Compass 2009-2017.5/Patriot 2009-2017 8

- Dodge Ram 1500 2009-2011,
Dodge Ram 2500/3500 2010-2011,
Dodge Ram Chassis Cab 2011/
Ram 1500/2500/3500 2012,
Ram Chassis Cab 3500/4500/5500 2012..... 9-10
- Ram C/V Tradesman 2012-2015..... 10
- Jeep Commander/
Grand Cherokee 2008-2010..... 11
- Jeep Wrangler 2007-2010** 12
- Jeep Wrangler 2011-up** 12-13
- Mitsubishi Raider 2008-2009 13

Kit Assembly

- ISO DDIN radio provision..... 14

DASH DISASSEMBLY

Chrysler Aspen 2008-2009

Dodge Durango 2008-2009

1. Unsnap and remove storage cup holder assembly. (Figure A)
2. Remove (2) screws from bottom edge of center dash trim panel. Unsnap and remove the panel. (Figure B)
3. Remove (4) screws securing the radio. Unplug and remove radio. (Figure C)

Continue to Kit Assembly

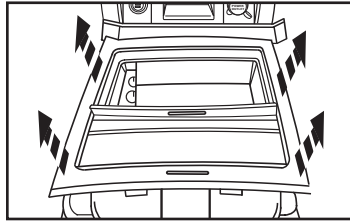

(Figure A)

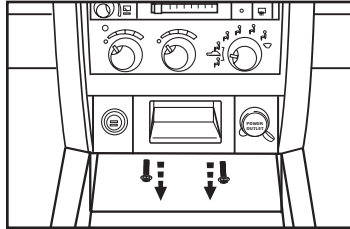

(Figure B)

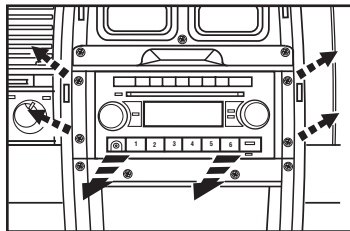

(Figure C)

Chrysler Sebring 2007-2010

1. Unclip entire panel surrounding radio including A/C vents and clock. Unplug and remove panel. (Figure A)
2. Remove (4) 7mm screws securing radio. Unplug and remove radio. (Figure B)

Continue to Kit Assembly

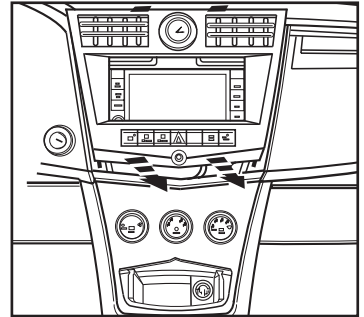

(Figure A)

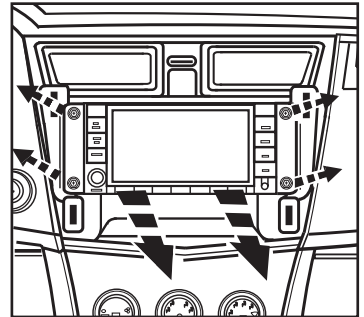

(Figure B)

DASH DISASSEMBLY

Chrysler Town & Country 2008-2010 Dodge Grand Caravan 2008-2010

1. Remove (2) screw covers facing up above radio then remove the (2) Phillips screws exposed. (Figure A)
2. Lift up on panel above radio then remove (2) Phillips screws exposed at front edge of radio trim panel. (Figure B)
3. Remove (3) plastic push pins per side of bottom trim panel then slide panel toward rear of van to access (2) screws on bottom of radio trim panel. (Figure C)

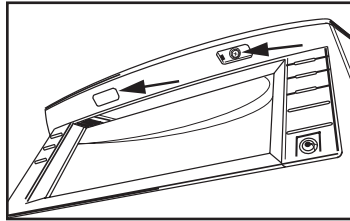

(Figure A)

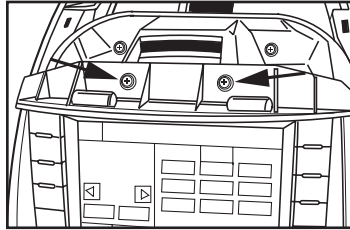

(Figure B)

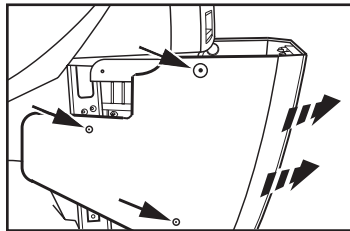

(Figure C)

4. Remove (2) Phillips screws exposed at bottom edge radio trim panel. (Figure D)
5. Unclip and remove entire panel surrounding radio including climate controls, vents and clock. (Figure E)
6. Remove (4) Phillips screws securing radio. (Figure F)

Continue to Kit Assembly

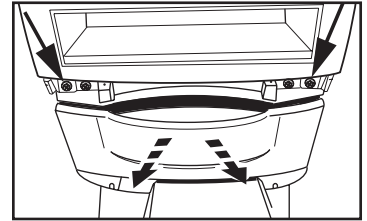

(Figure D)

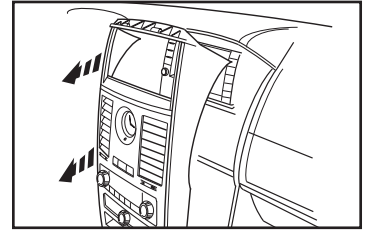

(Figure E)

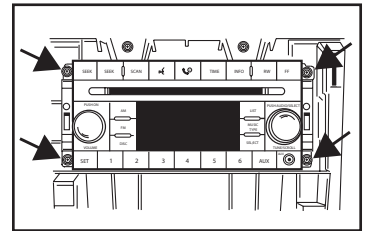

(Figure F)

DASH DISASSEMBLY

Chrysler Town & Country 2011-2017

Dodge Grand Caravan 2011-up

Volkswagen Routan 2009-2013

1. Unclip and remove the radio trim panel. (Figure A)
2. Remove (4) Torx securing the radio. (Figure B)

Continue to Kit Assembly

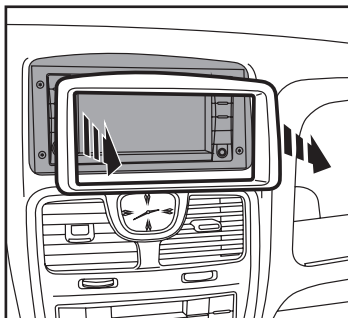

(Figure A)

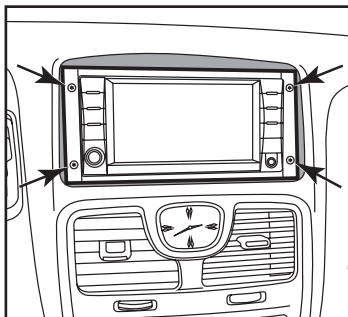

(Figure B)

Chrysler 200 2011-2014

1. Unclip and remove the radio trim panel. (Figure A)
2. Remove (4) Torx securing the radio. (Figure B)

Continue to Kit Assembly

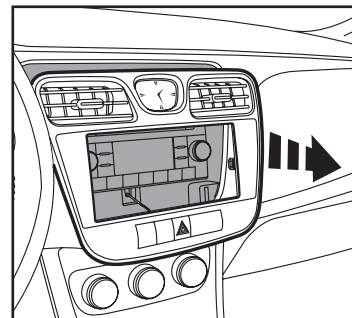

(Figure A)

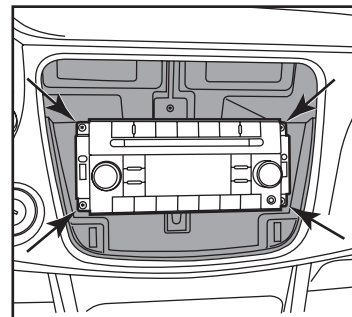

(Figure B)

DASH DISASSEMBLY

Chrysler 300/300C 2008-2010

Dodge Magnum/Charger 2008-2010

1. Unsnap and remove center dash trim panel. (Figure A)
2. Remove (4) screws securing the radio. Disconnect and remove the radio. (Figure B)

Continue to Kit Assembly

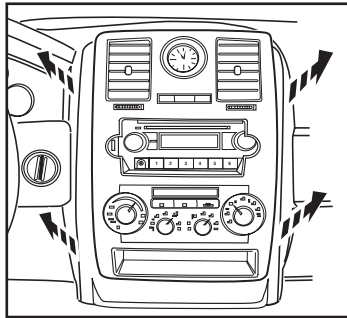

(Figure A)

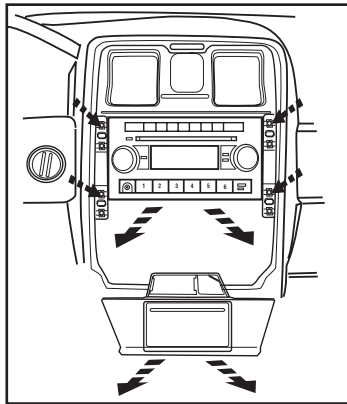

(Figure B)

Dodge Avenger 2008-2014

1. Unclip and remove the center console trim panel. (Figure A)
2. Unclip the center dash trim panel. (Figure B)
3. Remove (4) screws securing the radio. Disconnect and remove the radio. (Figure C)
4. Remove (3) screws securing the radio rear support bracket and remove the bracket. (Figure D)

Continue to Kit Assembly

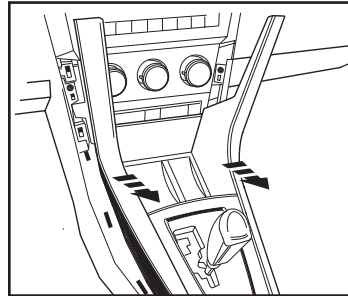

(Figure A)

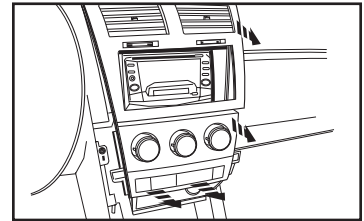

(Figure B)

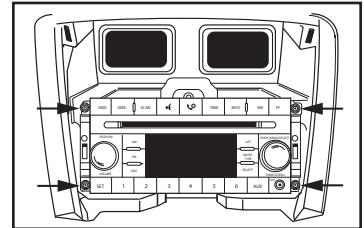

(Figure C)

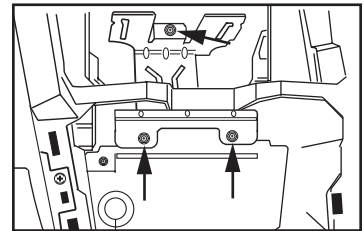

(Figure D)

DASH DISASSEMBLY

Dodge Dakota 2008-2011

1. Unclip and remove the trim panel surrounding the radio. (Figure A)
2. Remove (4) Phillips screws securing the radio. (Figure B)

Continue to Kit Assembly

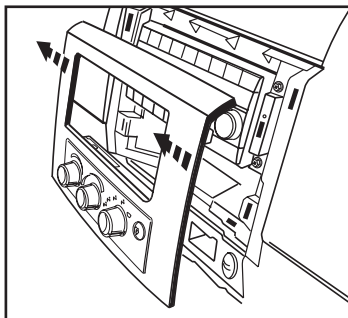

(Figure A)

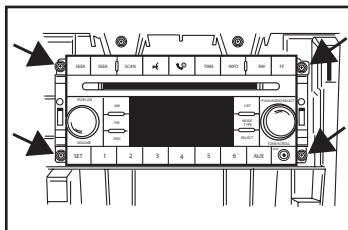

(Figure B)

Dodge Nitro 2007-2011

Jeep Liberty 2008-2012

1. Unclip entire panel surrounding radio and climate controls, including A/C vents. Unplug and remove panel. (Figure A)
2. Remove (4) 7mm screws securing radio. Unplug and remove radio. (Figure B)

Continue to Kit Assembly

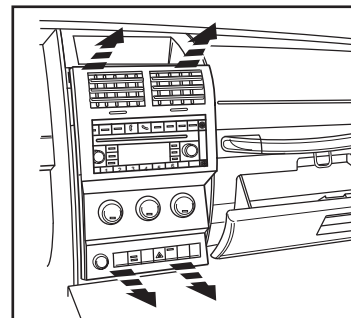

(Figure A)

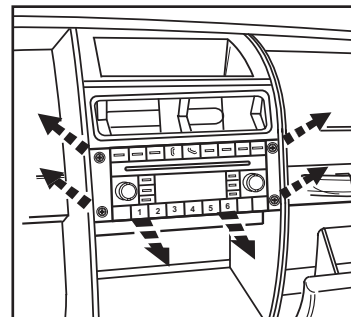

(Figure B)

DASH DISASSEMBLY

Dodge Journey 2009-2010

(modifications to radio cavity required)

1. Unclip and remove the entire factory radio trim panel including the A/C controls. (Figure A)

Tip: Open the compartment door at the top of the radio trim panel.

2. Remove (4) 7mm screws securing radio to dash to remove. (Figure B)

Note: The top of the metal bracket in the sub dash will need to be cut to allow for the clearance of the Double DIN radio's chassis. (Figure C)

Continue to Kit Assembly

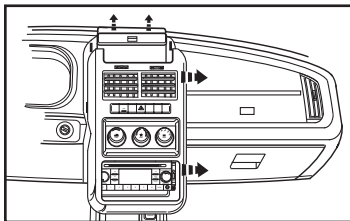

(Figure A)

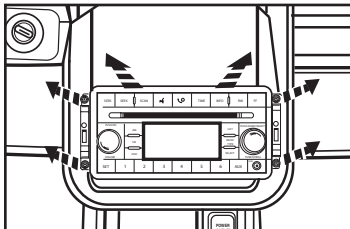

(Figure B)

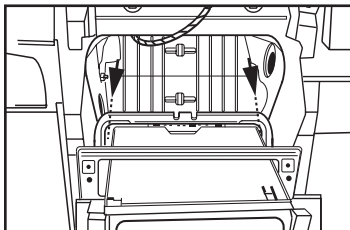

(Figure C)

Dodge Caliber 2009-2012

Dodge Challenger 2008-2014

Jeep Compass 2009-2017.5

Jeep Patriot 2009-2017

1. Unsnap and move shifter trim to the side. (Figure A)
2. Unsnap center dash trim panel (do not remove until climate controls are removed). (Figure A)
3. Remove (4) Phillips screws holding climate control panel to backside of the center dash panel.
4. Remove (4) 7mm screws securing radio. Unplug and remove radio.
5. The metal bracket in the sub-dash will need to be removed for the aftermarket Double DIN radio's depth.

Continue to Kit Assembly

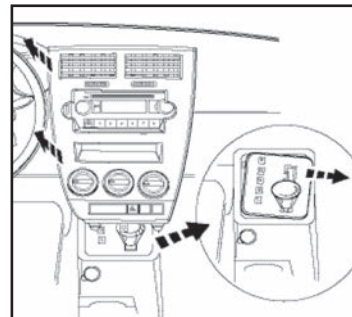

(Figure A)

DASH DISASSEMBLY

Dodge Ram 1500 2009-2011

Dodge Ram 2500/3500 2010-2011

Dodge Ram Chassis Cab 2011

Ram 1500/2500/3500 2012

Ram Chassis Cab 3500/4500/5500 2012

1. Remove (1) T-25 Torx screw in the compartment next to the cup holders. (Figure A)
2. Remove (2) Phillips screws in the pocket below the climate control in the front of the center console. (Figure B)
3. Remove (2) 9/32" screws in the cup holders. (Figure C)



(Figure A)

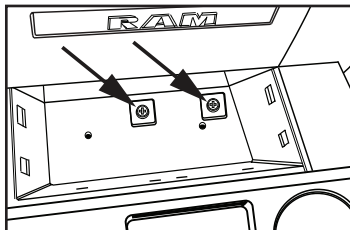

(Figure B)

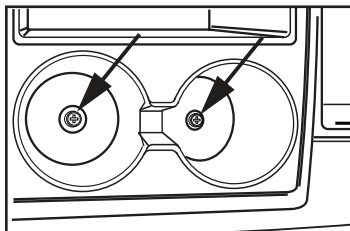

(Figure C)

4. Push down on the collar below the shifter then pull the shifter straight up to remove. (Figure D)
5. Unclip and remove the top of the center console including the cup holders. (Figure E)
6. Unclip and remove the trim panel from the accessory socket on the radio trim panel, then remove (1) T-25 Torx screw. (Figure F)

Continued on the next page

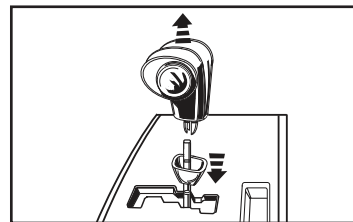

(Figure D)

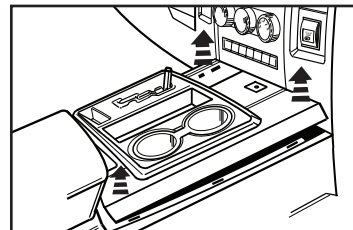

(Figure E)

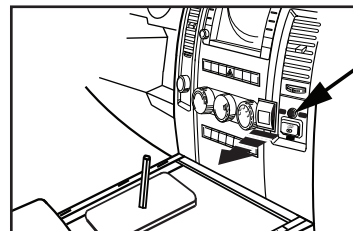

(Figure F)

DASH DISASSEMBLY

Dodge Ram 1500 2009-2011

Dodge Ram 2500/3500 2010-2011

Dodge Ram Chassis Cab 2011

Ram 1500/2500/3500 2012

Ram Chassis Cab 3500/4500/5500 2012

(continued)

7. Remove (2) T25 Torx screws from the top of the radio trim panel. (Figure G)
8. Unclip and remove the entire radio trim panel including the climate controls. (Figure H)
9. Remove (4) 9/32" screws securing the radio. (Figure I)

Continue to Kit Assembly

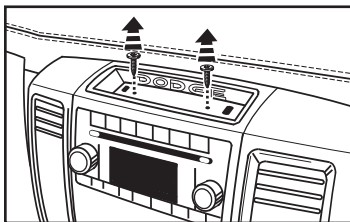

(Figure G)

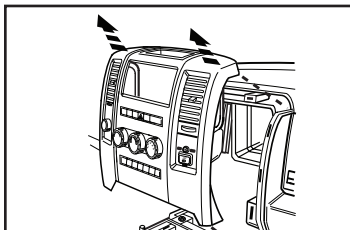

(Figure H)

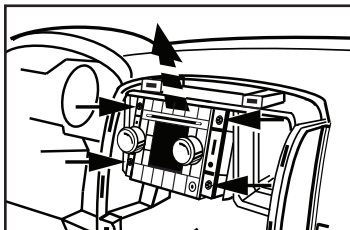

(Figure I)

Ram C/V Tradesman 2012-2015

1. Remove the radio trim bezel. (Figure A)
2. Remove (4) screws securing the radio to the dash. (Figure B)

Continue to Kit Assembly

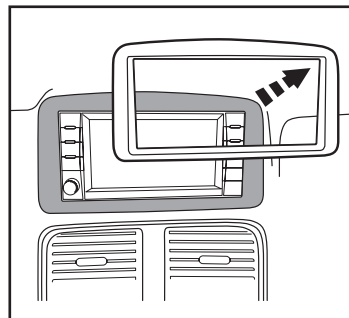

(Figure A)

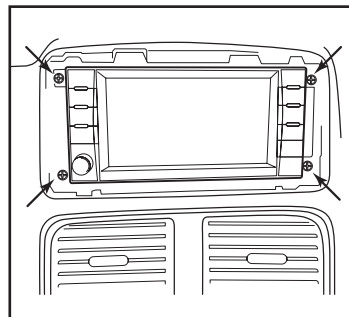

(Figure B)

DASH DISASSEMBLY

Jeep Commander/Grand Cherokee 2008-2010

1. Unsnap and remove the small trim around the console shifter. (Figure A)
2. Unsnap and remove the larger trim around the console shifter. (Figure B)

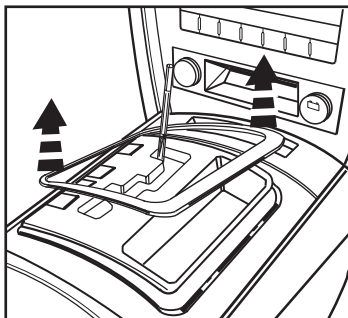

(Figure A)

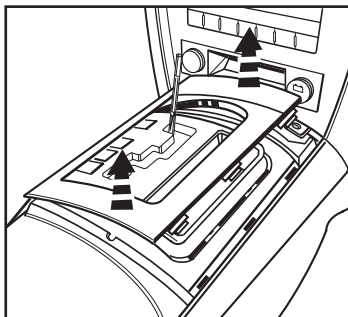

(Figure B)

3. Remove (1) Phillips screw from inside the small storage pocket in the lower dash, between the power outlets. (Figure C)
4. Unsnap and remove the dash panel from around the radio (including climate controls). (Figure D)
5. Remove (4) Phillips screws securing the radio. Unplug and remove radio.

Continue to Kit Assembly

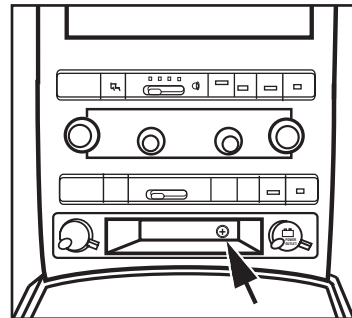

(Figure C)

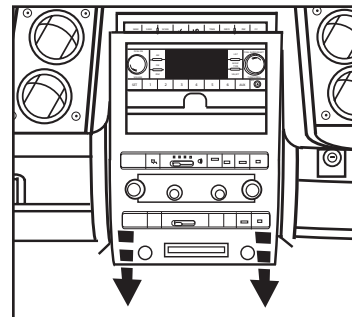

(Figure D)

DASH DISASSEMBLY

Jeep Wrangler 2007-2010

(modifications to radio cavity required)

1. Unclip and remove the lower center trim below A/C controls. (Figure A)
2. Remove (2) Phillips screws exposed behind lower center panel. (Figure A)
3. Unclip and remove the upper center trim starting towards the rear of the panel. (Figure A)
4. Remove (2) Phillips screws exposed behind upper center panel. (Figure A)
5. Unclip and remove entire panel surrounding radio and climate controls, including A/C vents.
6. Remove (4) 7mm screws securing radio. Unplug and remove radio. (Figure B)

Note: The top of the metal bracket in the sub dash will need to be cut to allow for the clearance of the Double DIN radio's chassis.

Continue to Kit Assembly

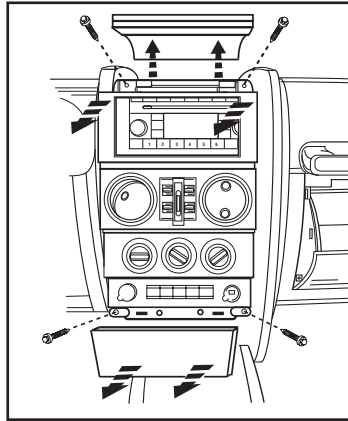

(Figure A)

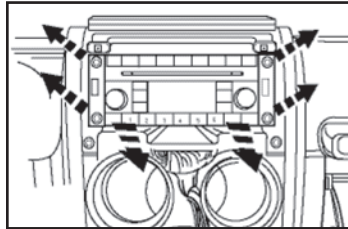

(Figure B)

Jeep Wrangler 2011-up

(modifications to radio cavity required)

1. Unclip and remove the power window switches then remove (1) 9/32" screw from underneath. (Figure A)
2. Unclip and remove the panel below the steering column.
3. Remove (2) 9/32" screws from the bottom edge of the radio/instrument cluster trim panel on either side of the steering column. (Figure B, C)

Continued on the next page

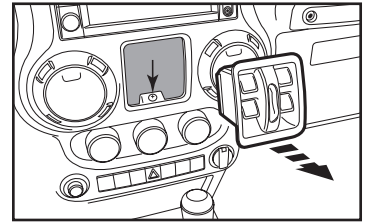

(Figure A)

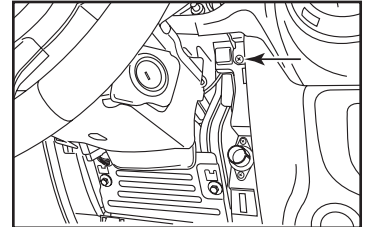

(Figure B)

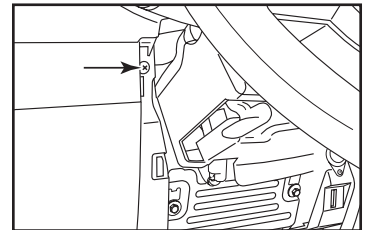

(Figure C)

DASH DISASSEMBLY

Jeep Wrangler 2011-up (continued) (modifications to radio cavity required)

4. Remove pad in pocket on top center of dash then remove (1) 9/32" screw underneath. Remove dash panel from around radio and instrument cluster. (Figure D)
5. Remove (4) 9/32" screws securing the radio. Unplug and remove radio.
6. Remove (2) 9/32" screws securing the metal bracket inside of the dash cavity and remove it for depth. (Figure E)
7. A small cut in the plastic at the top of the radio cavity will be required for most double DIN radios. (Figure F)

Continue to Kit Assembly

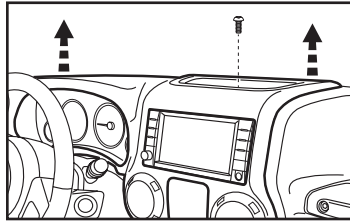

(Figure D)

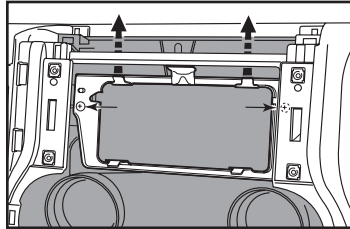

(Figure E)

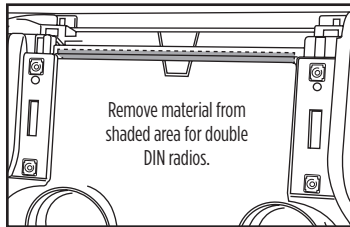

(Figure F)

Mitsubishi Raider 2008-2009

1. Unsnap and remove center dash panel. (Figure A)
2. Remove (4) 7mm screws securing the radio. Unplug and remove radio.

Continue to Kit Assembly

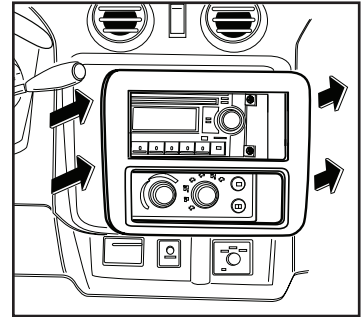

(Figure A)

KIT ASSEMBLY

ISO DDIN radio provision

1. Depending on the style of radio to be installed, secure either the "A" "Long nose" (wide) DDIN trim panels, or "B" "Short nose" (narrow) DDIN trim panels, to the ISO DDIN radio brackets using (4) #8 x 1/4" Phillips screws provided. (Figure A)

Note: The trim panels are stamped on the back indicating the top and which style of radio the trim panel should be used for. "A" for long nose radios, "B" for short nose radios.

2. Secure the completed bracket assembly to the radio using the screws supplied with the radio. (Figure B)
3. Locate the factory wiring harness and antenna connector in the dash. Metra recommends using the proper mating adapter from Metra or AXCESS. Test the unit for proper operation.
4. Reassemble the dash in reverse order of disassembly.

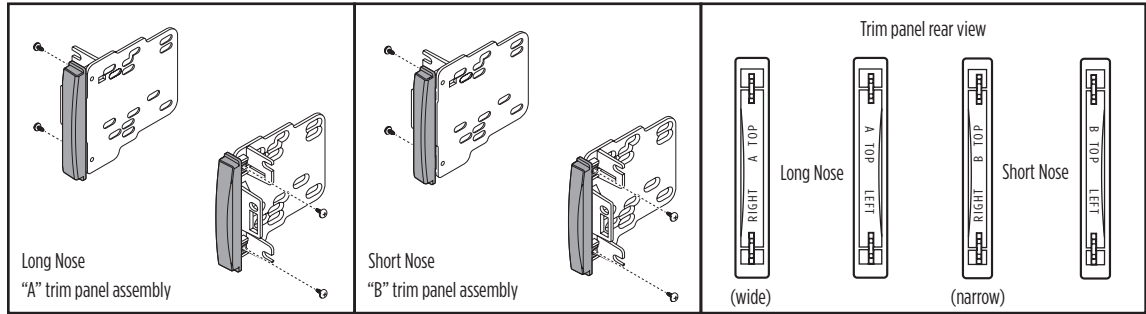

(Figure A)

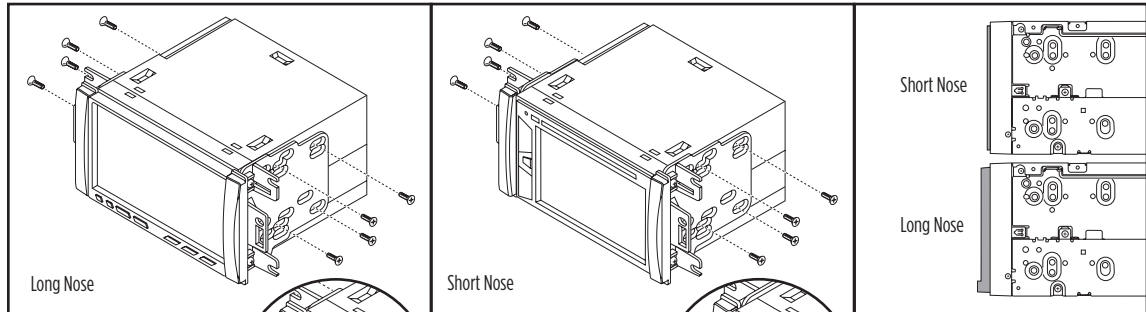

(Figure B)





95-6511
INSTALLATION INSTRUCTIONS



IMPORTANT

If you are having difficulties with the installation of this product, please call our Tech Support line at 1-800-253-TECH. Before doing so, look over the instructions a second time, and make sure the installation was performed exactly as the instructions are stated. Please have the vehicle apart and ready to perform troubleshooting steps before calling.



KNOWLEDGE IS POWER

Enhance your installation and fabrication skills by enrolling in the most recognized and respected mobile electronics school in our industry. Log onto www.installerinstitute.com or call 800-354-6782 for more information and take steps toward a better tomorrow.



Metra recommends MECP certified technicians



Chrysler Multikit 2007 y mas*

* Visite MetraOnline.com para las aplicaciones específicas del vehículo hasta la fecha.

CARACTERÍSTICAS DEL KIT

- Provisión de radio ISO DDIN
- Dos tamaños de paneles de ajuste acomodan radios DIN de “nariz larga” o “nariz corta”
- Texturado

COMPONENTES DEL KIT

- A) Paneles de acabado DDIN “Long nose” (ancho) • B) Paneles de ajuste DDIN “nariz corta” (estrecho) • C) Soportes ISO DDIN
- D) (4) Tornillos Phillips #8 de 1/4”

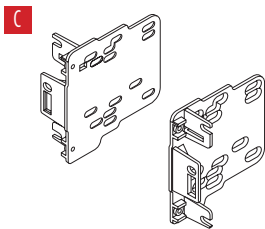
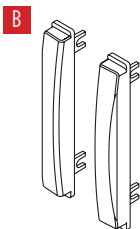
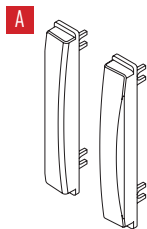

INDICE

Ver página 2

CABLEADO Y CONEXIONES DE ANTENA

(se venden por separado)

Arnés de cables: XSVI-6522-NAV • CHTO-03

Adaptador de antena: • 40-EU10

TOOLS REQUIRED

- Panel removal tool • Phillips screwdriver
 - Socket set • Herramienta de corte
- (modificaciones de sub-tablero requeridas para la mayoría de las aplicaciones)

¡PRECAUCIÓN! Todos los accesorios, interruptores, paneles de controles de clima y especialmente las luces del indicador de las bolsas de aire deben estar conectados antes ciclar la ignición. Además, no quite el radio de fábrica con la llave en la posición de encendido ni con el vehículo funcionando.

APLICACIONES

Chrysler

200	2011-2014
300/300C	2008-2010
Aspen	2008-2009
Sebring	2007-2010
Town and Country	2008-2017

Dodge

Avenger	2008-2014
Caliber	2009-2012
Challenger	2008-2014
Charger	2008-2010
Dakota	2008-2011
Durango	2008-2009
Grand Caravan	2008 y mas
Journey**	2009-2010
Magnum	2008-2009
Nitro	2007-2011
Ram 1500	2009-2011
Ram 2500/3500	2010-2011
Ram Chassis Cab	2011

Jeep

Compass	2009-2017.5
Commander	2008-2010
Grand Cherokee	2008-2010
Liberty	2008-2012
Patriot	2009-2017
Wrangler**	2007 y mas

Mitsubishi

Raider	2008-2009
--------------	-----------

Ram

1500/2500/3500	2012
Chassis Cab 3500/4500/5500	2012
C/V Tradesman	2012-2015

VW

Routan	2009-2013
--------------	-----------

***(se requieren modificaciones en la cavidad de la radio)*

INDICE

Desmontaje del tablero

- Chrysler Aspen 2008-2009/ Dodge Durango 2008-2009	3
- Chrysler Sebring 2007-2010	3
- Chrysler Town and Country 2008-2010, Dodge Grand Caravan 2008-2010	4
- Chrysler Town and Country 2011-2017, Dodge Grand Caravan 2011 y mas, Volkswagen Routan 2009-2013	5
- Chrysler 200 2011-2014	5
- Chrysler 300/300C 2008-2010, Dodge Magnum 2008-2009/ Charger 2008-2010	6
- Dodge Avenger 2008-2014	6
- Dodge Nitro 2007-2011, Jeep Liberty 2008-2012	7
- Dodge Journey 2009-2010**	8
- Dodge Caliber 2009-2012/Challenger 2008-2014, Jeep Compas 2009-2017.5/Patriot 2009-2017	8

- Dodge Ram 1500 2009-2011, Dodge Ram 2500/3500 2010-2011, Dodge Ram Chassis Cab 2011/ Ram 1500/2500/3500 2012, Ram Chassis Cab 3500/4500/5500 2012	9-10
- Ram C/V Tradesman 2012-2015	10
- Jeep Commander/ Grand Cherokee 2008-2010	11
- Jeep Wrangler 2007-2010**	12
- Jeep Wrangler 2011 y mas**	12-13
- Mitsubishi Raider 2008-2009	13

Ensamble del kit

- Provisión de radio ISO DDIN	14
-------------------------------------	----

DESMONTAJE DEL TABLERO

Chrysler Aspen 2008-2009

Dodge Durango 2008-2009

1. Suelte a presión y retire el ensamble de almacenamiento/portavasos. (Figura A)
2. Retire los (2) tornillos del borde inferior del panel de la moldura del tablero central. Suelte y retire el panel. (Figura B)
3. Retire los (4) tornillos que sostienen el radio. Desconecte y retire el radio. (Figura C)

Continuará al ensamble del kit

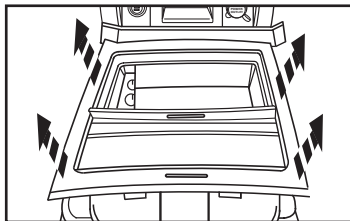

(Figura A)

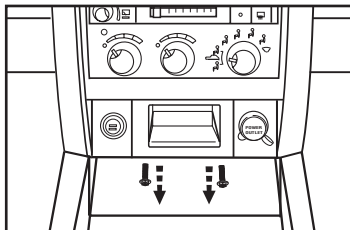

(Figura B)

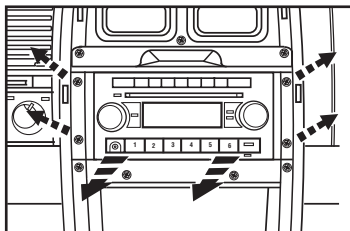

(Figura C)

Chrysler Sebring 2007-2010

1. Desenganche todo el panel que rodea el radio, incluyendo las rejillas del aire acondicionado y el reloj. Desconecte y retire el panel. (Figura A)
2. Retire los (4) tornillos de 7mm que sostienen el radio. Desconecte y retire el radio. (Figura B)

Continuará al ensamble del kit

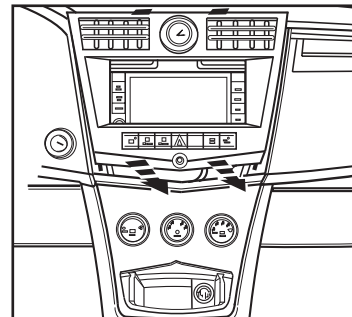

(Figura A)

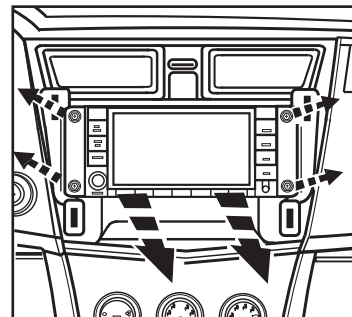

(Figura B)

DESMONTAJE DEL TABLERO

Chrysler Town & Country 2008-2010 Dodge Grand Caravan 2008-2010

1. Retire las (2) tapas de los tornillos orientadas hacia arriba sobre el radio, luego retire los (2) tornillos Phillips expuestos. (Figura A)
2. Levante el panel de arriba del radio y luego retire los (2) tornillos Phillips expuestos en el borde frontal del panel de la moldura del radio. (Figura B)
3. Retire las (3) chinchetas de plástico por lado del panel de la moldura inferior y luego del panel lateral hacia la parte trasera de la van para obtener acceso a los (2) tornillos de la parte inferior del panel de la moldura del radio. (Figura C)

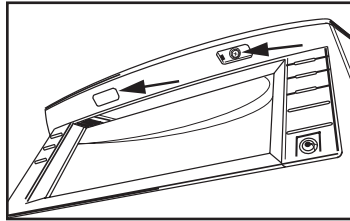

(Figura A)

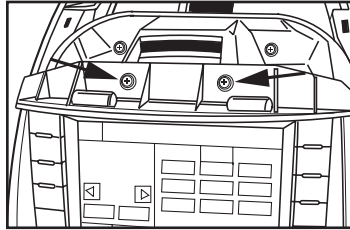

(Figura B)

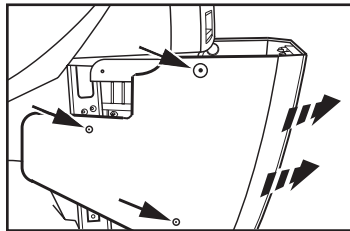

(Figura C)

4. Retire los (2) tornillos Phillips expuestos del panel de la moldura del radio del borde inferior. (Figura D)
5. Desenganche y retire todo el panel que rodea el radio, incluyendo los controles del clima, las rejillas y el reloj. (Figura E)
6. Retire los (4) tornillos Phillips que sostienen el radio. (Figura F)

Continuará al ensamble del kit

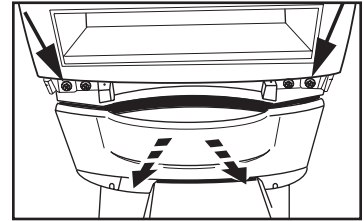

(Figura D)

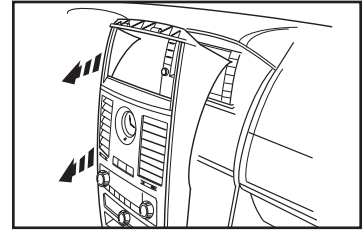

(Figura E)

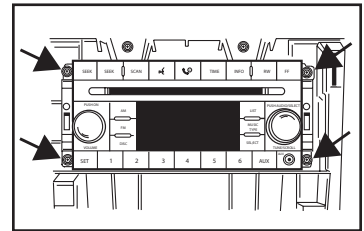

(Figura F)

DESMONTAJE DEL TABLERO

Chrysler Town & Country 2011-2017

Dodge Grand Caravan 2011 y mas

Volkswagen Routan 2009-2013

1. Desenganche y retire el panel de moldura para radio. (Figura A)
2. Retire los (4) tornillos Torx que sostienen el radio. (Figura B)

Continuará al ensamble del kit

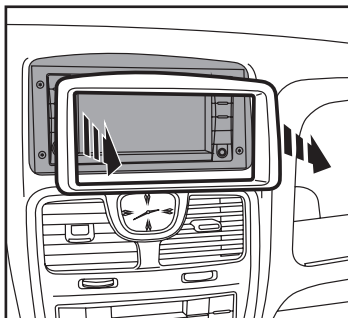

(Figura A)

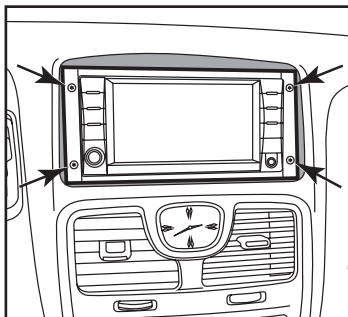

(Figura B)

Chrysler 200 2011-2014

1. Desenganche y retire el panel de moldura para radio. (Figura A)
2. Retire los (4) tornillos Torx que sostienen el radio. (Figura B)

Continuará al ensamble del kit

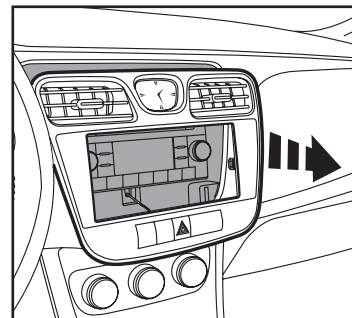

(Figura A)

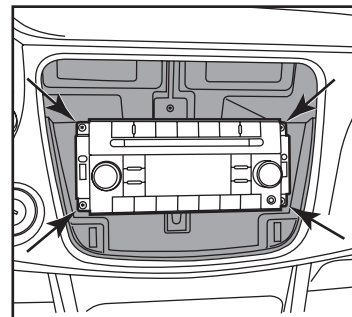

(Figura B)

DESMONTAJE DEL TABLERO

Chrysler 300/300C 2008-2010

Dodge Magnum 2008-2009

Dodge Charger 2008-2010

1. Suelte a presión y retire el panel de la moldura del tablero central. (Figura A)
2. Retire los (4) tornillos que sostienen el radio. Desconecte y retire el radio. (Figura B)

Continuará al ensamble del kit

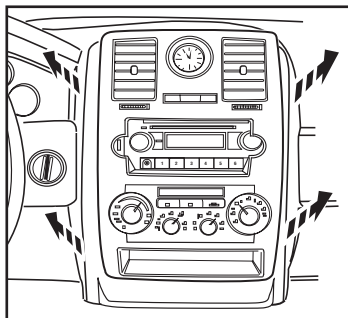

(Figura A)

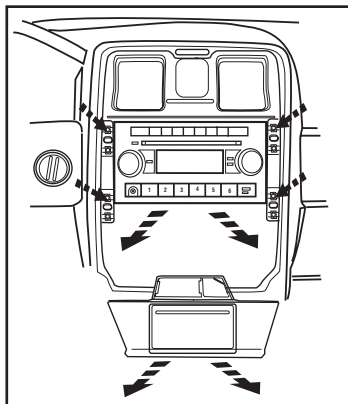

(Figura B)

Dodge Avenger 2008-2014

1. Desenganche y retire el panel de la moldura de la consola central. (Figura A)
2. Desenganche el panel de la moldura del tablero central. (Figura B)
3. Retire los (4) tornillos que sostienen el radio. Desconecte y retire el radio. (Figura C)
4. Retire los (3) tornillos que sujetan el soporte de apoyo trasero del radio y retire el soporte. (Figura D)

Continuará al ensamble del kit

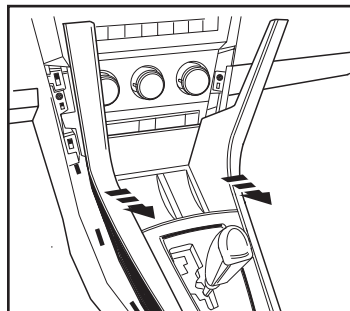

(Figura A)

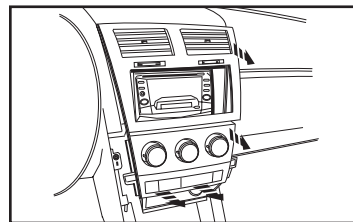

(Figura B)

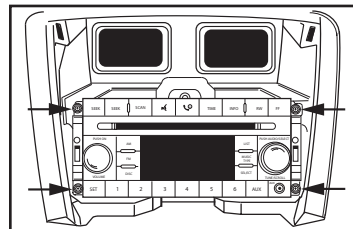

(Figura C)

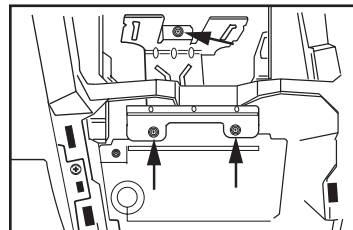

(Figura D)

DESMONTAJE DEL TABLERO

Dodge Dakota 2008-2011

1. Desenganche y retire el panel de moldura que rodea el radio. (Figura A)
2. Retire los (4) tornillos Phillips que sostienen el radio. (Figura B)

Continuará al ensamble del kit

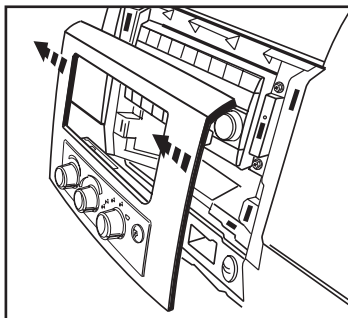

(Figura A)

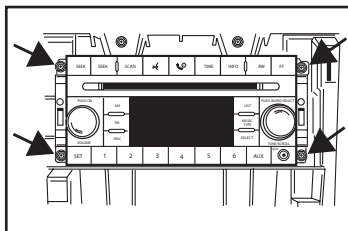

(Figura B)

Dodge Nitro 2007-2011

Jeep Liberty 2008-2012

1. Desenganche todo el panel que rodea el radio y los controles del clima, incluyendo las rejillas del aire acondicionado. Desconecte y retire el panel. (Figura A)
2. Retire los (4) tornillos de 7mm que sostienen el radio. Desconecte y retire el radio. (Figura B)

Continuará al ensamble del kit

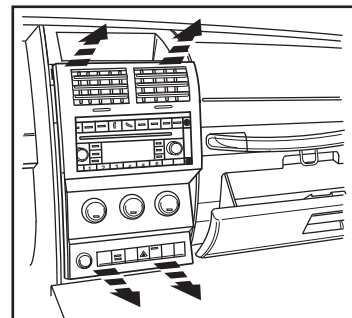

(Figura A)

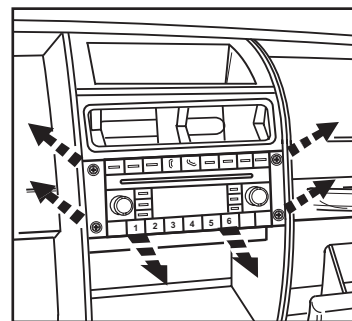

(Figura B)

DESMONTAJE DEL TABLERO

Dodge Journey 2009-2010

(modificaciones a la cavidad de radio requerido)

1. Desenganche y retire todo el panel de la moldura del radio de fábrica, incluyendo los controles del aire acondicionado. (Figura A)

Sugerencia: Abra la puerta del compartimento de la parte superior del panel de la moldura del radio.

2. Retire los (4) tornillos de 7mm que sujetan el radio al tablero y retire. (Figura B)

Nota: La parte superior del soporte metálico del sub tablero tendrá que cortarse para permitir que haya suficiente espacio para el chasis del radio doble DIN. (Figura C)

Continuará al ensamble del kit

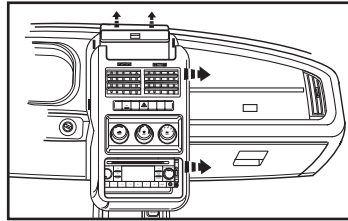

(Figura A)

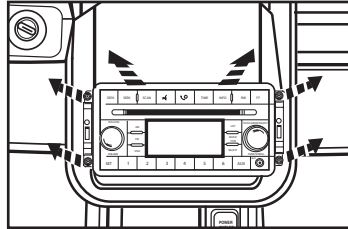

(Figura B)

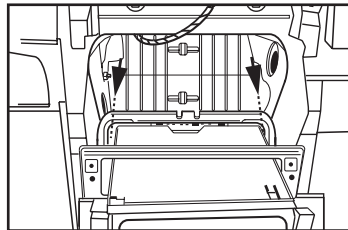

(Figura C)

Dodge Caliber 2009-2012

Dodge Challenger 2008-2014

Jeep Compass 2009-2017.5

Jeep Patriot 2009-2017

1. Suelte y mueva la moldura de la palanca de velocidades a un lado. (Figura A)
2. Suelte el panel de la moldura del tablero central (no lo retire hasta que se hayan retirado los controles de clima). (Figura A)
3. Retire los (4) tornillos Phillips que sostienen el panel de control de clima a la parte posterior del panel del tablero central.
4. Retire los (4) tornillos de 7mm que sostienen el radio. Desconecte y retire el radio.
5. El soporte metálico del sub tablero tendrá que retirarse por la profundidad del radio doble DIN de mercado secundario.

Continuará al ensamble del kit

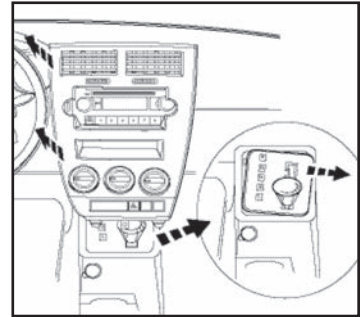

(Figura A)

DESMONTAJE DEL TABLERO

Dodge Ram 1500 2009-2011

Dodge Ram 2500/3500 2010-2011

Dodge Ram Chassis Cab 2011

Ram 1500/2500/3500 2012

Ram Chassis Cab 3500/4500/5500 2012

1. Retire (1) tornillo Torx T25 del compartimiento junto a los portavasos. (Figura A)
2. Retire los (2) tornillos Phillips de la cavidad debajo del control de clima al frente de la consola central. (Figura B)
3. Retire los (2) tornillos de 9/32" de los portavasos. (Figura C)



(Figura A)

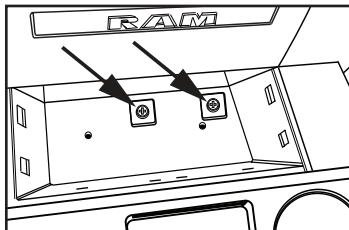

(Figura B)

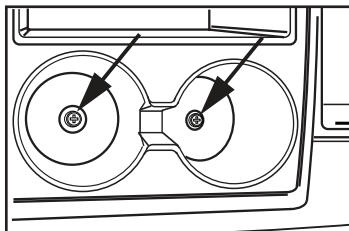

(Figura C)

4. Empuje hacia abajo el collar debajo de la palanca de velocidades, luego jale la palanca en línea recta hacia arriba para retirarla. (Figura D)
5. Desenganche y retire la parte superior de la consola central, incluyendo los portavasos. (Figura E)
6. Desenganche y retire el panel de la moldura del receptáculo de accesorios en el panel de la moldura del radio, luego retire (1) tornillo Torx T25. (Figura F)

Continúa en la página

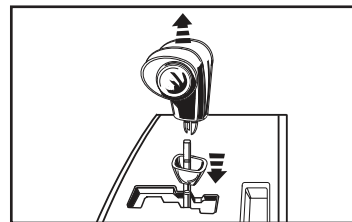

(Figura D)

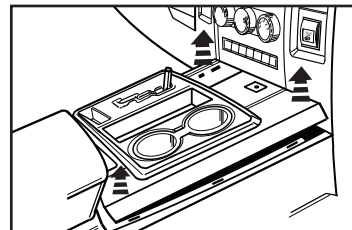

(Figura E)

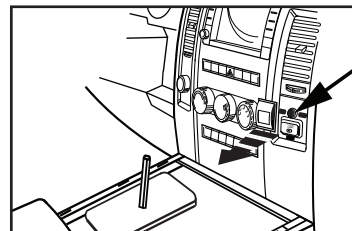

(Figura F)

DESMONTAJE DEL TABLERO

Dodge Ram 1500 2009-2011

Dodge Ram 2500/3500 2010-2011

Dodge Ram Chassis Cab 2011

Ram 1500/2500/3500 2012

Ram Chassis Cab 3500/4500/5500 2012

(cont.)

7. Retire los (2) tornillos Torx T25 de la parte superior del panel de la moldura del tablero. (Figura G)
8. Desenganche y retire todo el panel de la moldura del radio, incluyendo los controles del clima. (Figura H)
9. Retire los (4) tornillos de 9/32" que sostienen el radio. (Figura I)

Continuará al ensamble del kit

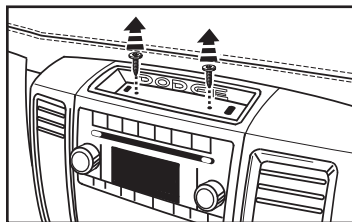

(Figura G)

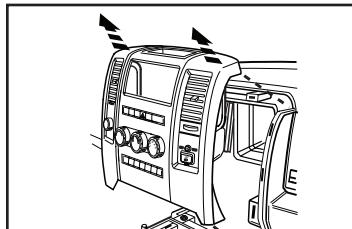

(Figura H)

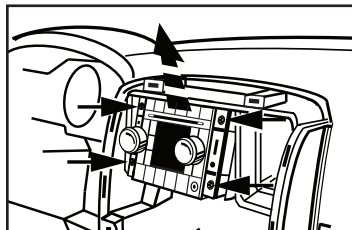

(Figura I)

Ram C/V Tradesman 2012-2015

1. Retire el embellecedor para radio. (Figura A)
2. Retire (4) tornillos que sujetan el radio en el salpicadero. (Figura B)

Continuará al ensamble del kit

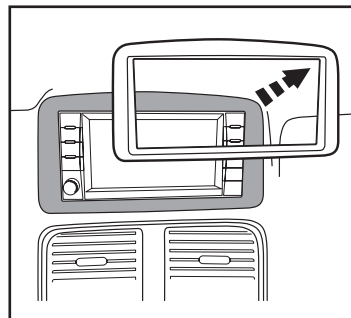

(Figura A)

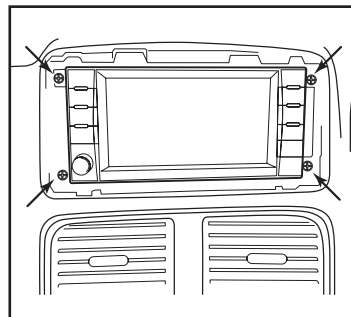

(Figura B)

DESMONTAJE DEL TABLERO

Jeep Commander/Grand Cherokee 2008-2010

1. Suelte a presión y retire la moldura pequeña de alrededor de la palanca de velocidades de la consola. (Figura A)
2. Suelte a presión y retire la moldura más grande alrededor de la palanca de velocidades de la consola. (Figura B)

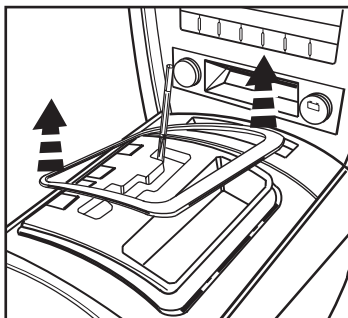

(Figura A)

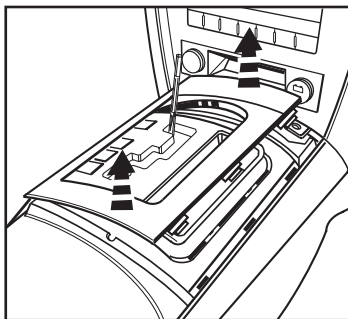

(Figura B)

3. Retire (1) tornillo Phillips del interior de la pequeña cavidad de almacenamiento del tablero inferior, entre los tomacorrientes. (Figura C)
4. Suelte a presión y retire el panel del tablero de alrededor del radio (incluyendo los controles del clima). (Figura D)
5. Retire los (4) tornillos Phillips que sostienen el radio. Desconecte y retire el radio.

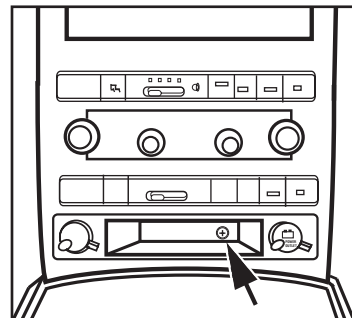

(Figura C)

Continuará al ensamble del kit

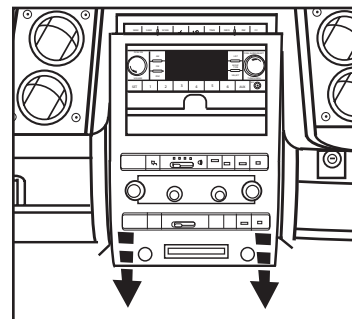

(Figura D)

DESMONTAJE DEL TABLERO

Jeep Wrangler 2007-2010

(modificaciones a la cavidad de radio requerido)

1. Desenganche y retire la moldura central inferior debajo de los controles del aire acondicionado. (Figura A)
2. Retire los (2) tornillos Phillips expuestos detrás del panel central inferior. (Figura A)
3. Desenganche y retire la moldura central superior, empezando hacia la parte trasera del panel. (Figura A)
4. Retire los (2) tornillos Phillips expuestos detrás del panel central superior. (Figura A)
5. Desenganche y retire todo el panel que rodea el radio y los controles del clima, incluyendo las rejillas del aire acondicionado.
6. Retire los (4) tornillos de 7mm que sostienen el radio. Desconecte y retire el radio. (Figura B)

Nota: La parte superior del soporte metálico del sub tablero tendrá que cortarse para permitir que haya suficiente espacio para el chasis del radio doble DIN.

Continuará al ensamble del kit

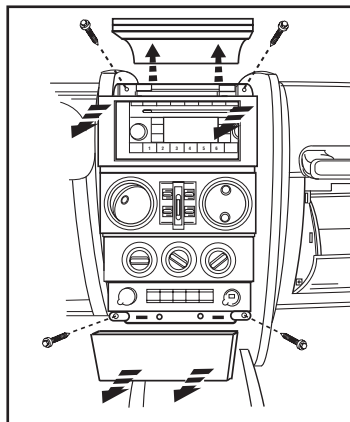

(Figura A)

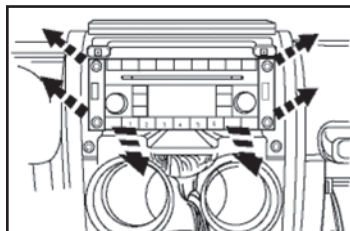

(Figura B)

Jeep Wrangler 2011 y mas

(modificaciones a la cavidad de radio requerido)

1. Soltar y quitar la ventana de interruptores de alimentación y luego retire (1) 9/32 "tornillo de debajo. (Figura A)
2. Suelte y quite el panel debajo de la columna de dirección.
3. Retire (2) 9/32 "tornillos desde el borde inferior del cuadro del panel de terminación del radio / instrumento a cada lado de la columna de dirección. (Figura B, C)

Continúa en la página

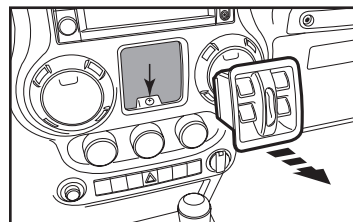

(Figura A)

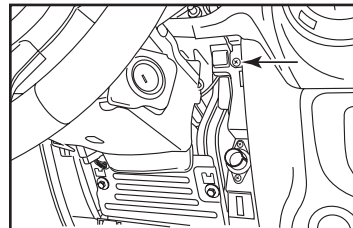

(Figura B)

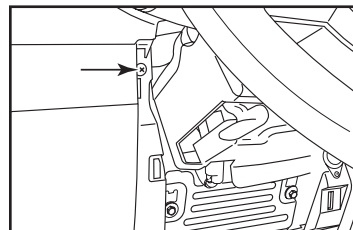

(Figura C)

DESMONTAJE DEL TABLERO

Jeep Wrangler 2011 y mas (cont.)

(modificaciones a la cavidad de radio requerido)

4. Quitar el disco en el bolsillo en la parte superior centro del tablero retire (1) 9/32 "por debajo de los tornillos. Retire tablero de instrumentos de todo radio y cuadro de instrumentos. (Figura D)
5. Retire (4) 9/32 "tornillos que sujetan el radio. Desenchufe y quite la radio.
6. Retire (2) 9/32 "tornillos que sujetan el soporte de metal en el interior de la cavidad del tablero y eliminar la profundidad. (Figura E)
7. Un pequeño corte en el plástico en la parte superior de la cavidad de radio se requiere para la mayoría de las radios doble DIN. (Figura F)

Continuará al ensamble del kit

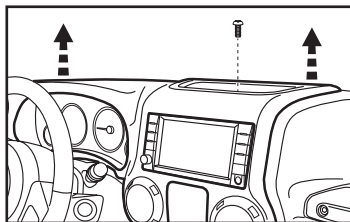

(Figura D)

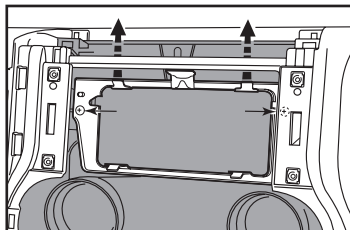

(Figura E)

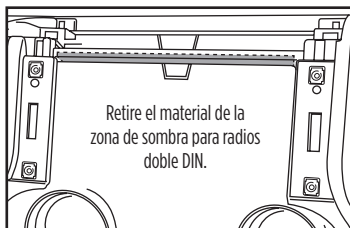

(Figura F)

Mitsubishi Raider 2008-2009

1. Suelte y retire el panel del tablero central. (Figura A)
2. Retire los (4) tornillos de 7mm que sostienen el radio. Desconecte y retire el radio.

Continuará al ensamble del kit

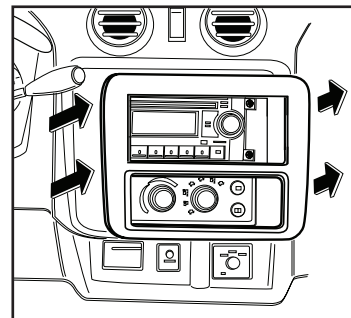

(Figura A)

ENSAMBLE DEL KIT

Provisión de radio ISO DDIN

1. Dependiendo del estilo de la radio que se instalará, asegure los paneles de guarnición DDIN "A" de "nariz larga" (ancha), o los paneles de guarnición DDIN "B" de nariz corta (angosta), a los soportes de radio ISO DDIN usando (4) tornillos Phillips # 8 x 1/4 "provistos. (Figura A)

Nota: Los paneles de moldura están estampados en la parte posterior, indicando la parte superior y el estilo de la radio para el que se debe usar el panel de moldura. "A" para radios nasales largas, "B" para radios de nariz corta.

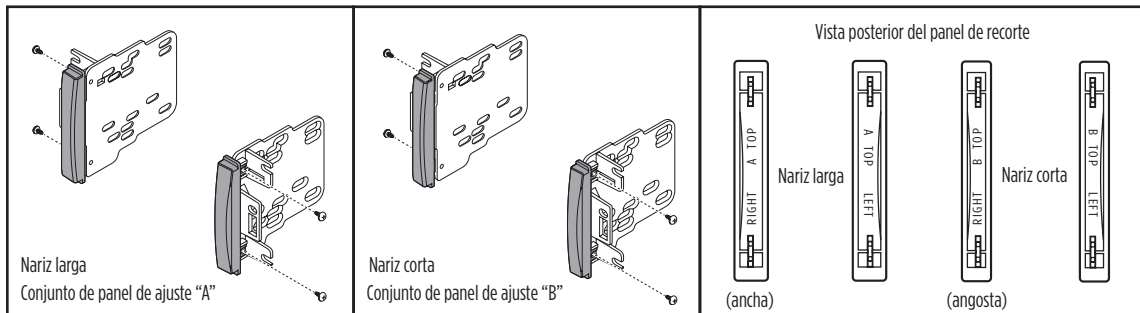

(Figura A)

2. Secure the ISO DDIN radio brackets with trim pieces to the radio using the screws supplied with the radio. (Figura B)
3. Ubique el arnés de cableado de fábrica y el conector de la antena en el tablero. Metra recomienda usar el adaptador de acoplamiento adecuado de Metra o AXCESS. Pruebe la radio para verificar que funcione correctamente.
4. Vuelva a montar el tablero en forma inversa al desmontaje.

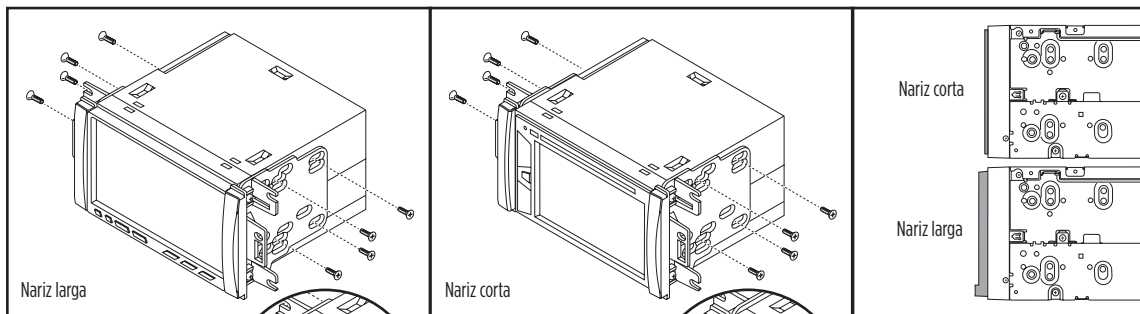

(Figura B)

ENSAMBLE DEL KIT



95-6511

INSTRUCCIONES DE INSTALACIÓN



IMPORTANTE

Si tiene dificultades con la instalación de este producto, llame a nuestra línea de soporte técnico al 1-800-253-TECH. Antes de hacerlo, revise las instrucciones por segunda vez y asegúrese de que la instalación se haya realizado exactamente como se indica en las instrucciones. Por favor tenga el vehículo desarmado y listo para ejecutar los pasos de resolución de problemas antes de llamar.



EL CONOCIMIENTO ES PODER

Mejore sus habilidades de instalación y fabricación inscribiéndose en la escuela de dispositivos electrónicos móviles más reconocida y respetada de nuestra industria. Regístrese en www.installerinstitute.com o llame al 800-354-6782 para obtener más información y avance hacia un futuro mejor.



**Metra recomienda MECP
Técnicos certificados**