





Examine all packaging material for small parts that may have come loose during shipment. Periodic checks are recommended to insure that all components are in proper position, tight and free from damage. Keep this assembly instruction for future reference. Adult assembly is required. The product of Hillsdale Furniture, LLC is designed for residential use only. Customer Service Phone Number: 502-562-0000

HDFBP

HARDWARE LIST

- A (10) 1/4" x 12 Allen Bolts
- B (24) 1/4" x 15 Sunk Bolts
- C (10) $\Phi 6.5 \times 1.5$ Spring Washers
- D (10) $\Phi 13 \times \Phi 6.5 \times 1.5$ Flat Washers
- E (1) Allen Wrench

PART	QTY	HARDWARE	PART	QTY	HARDWARE
A	10		B	24	
C	10		D	10	
E	1				

PARTS LIST

- F (1) Top
- G (2) Top Supports
- H (2) Leg Panels
- I (1) Bottom Shelf
- J (2) Cross Bars

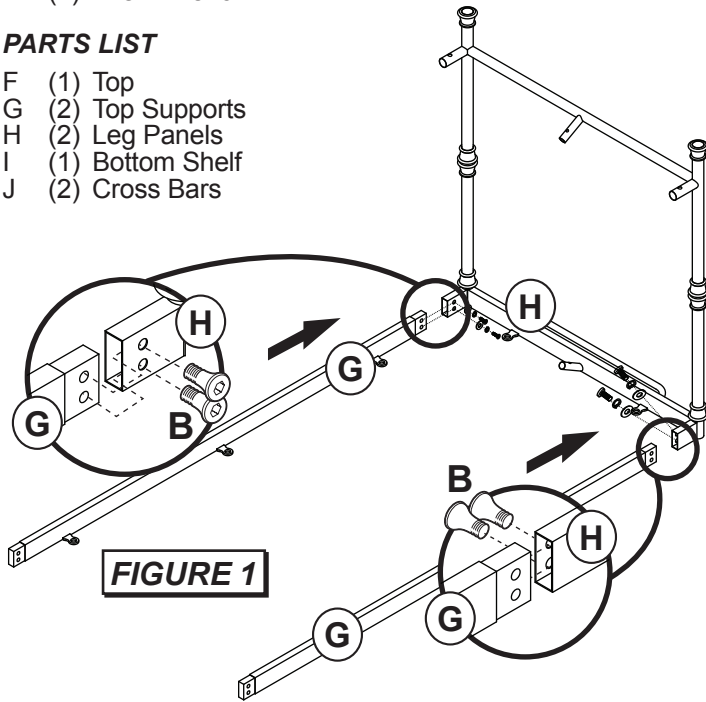

FIGURE 1

STEP 1 - Figure 1

Begin assembly by attaching Top Supports (G) to one Leg Panel (H) using 2 Sunk Bolts (B) per side.

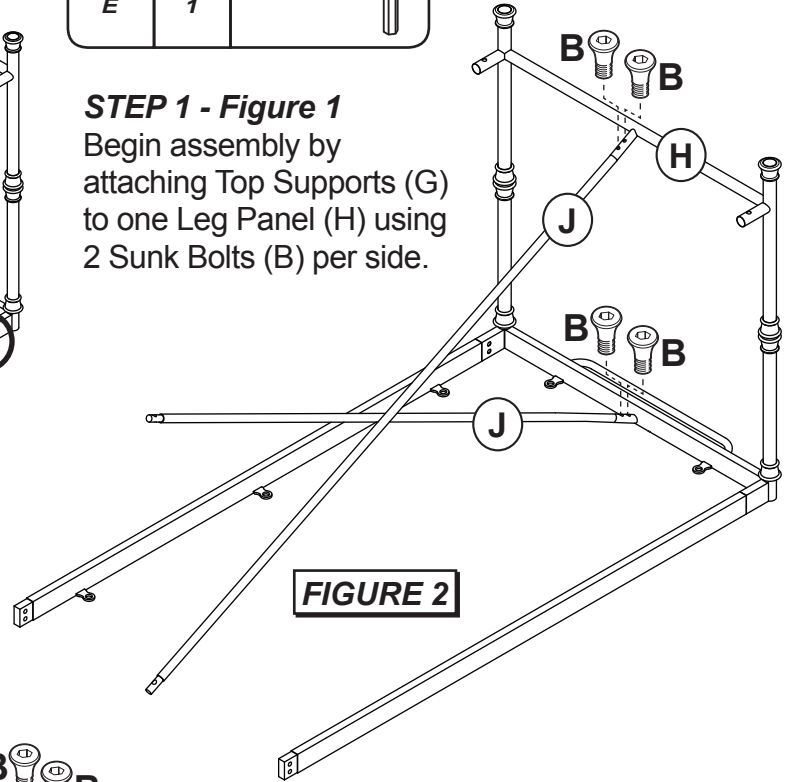

FIGURE 2

STEP 2 - Figure 2

Next attach one Cross Bar (J) to bottom of Leg Panel (H) using 2 Sunk Bolts (B). Attach other Cross Bar (J) to top of Leg Panel (H) using 2 Sunk Bolts (B). Do not fully tighten bolts for this step.

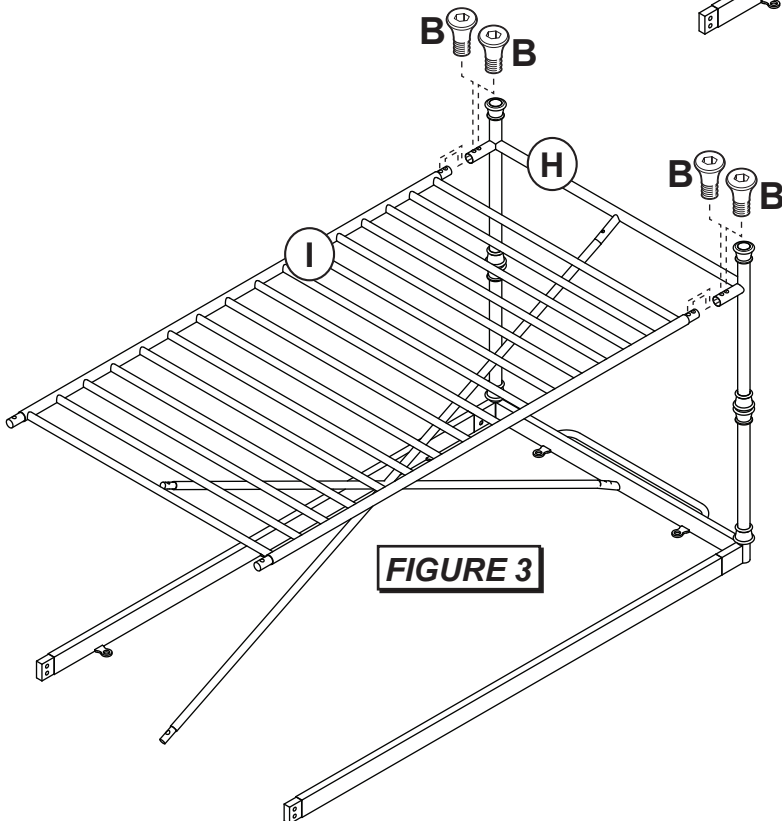
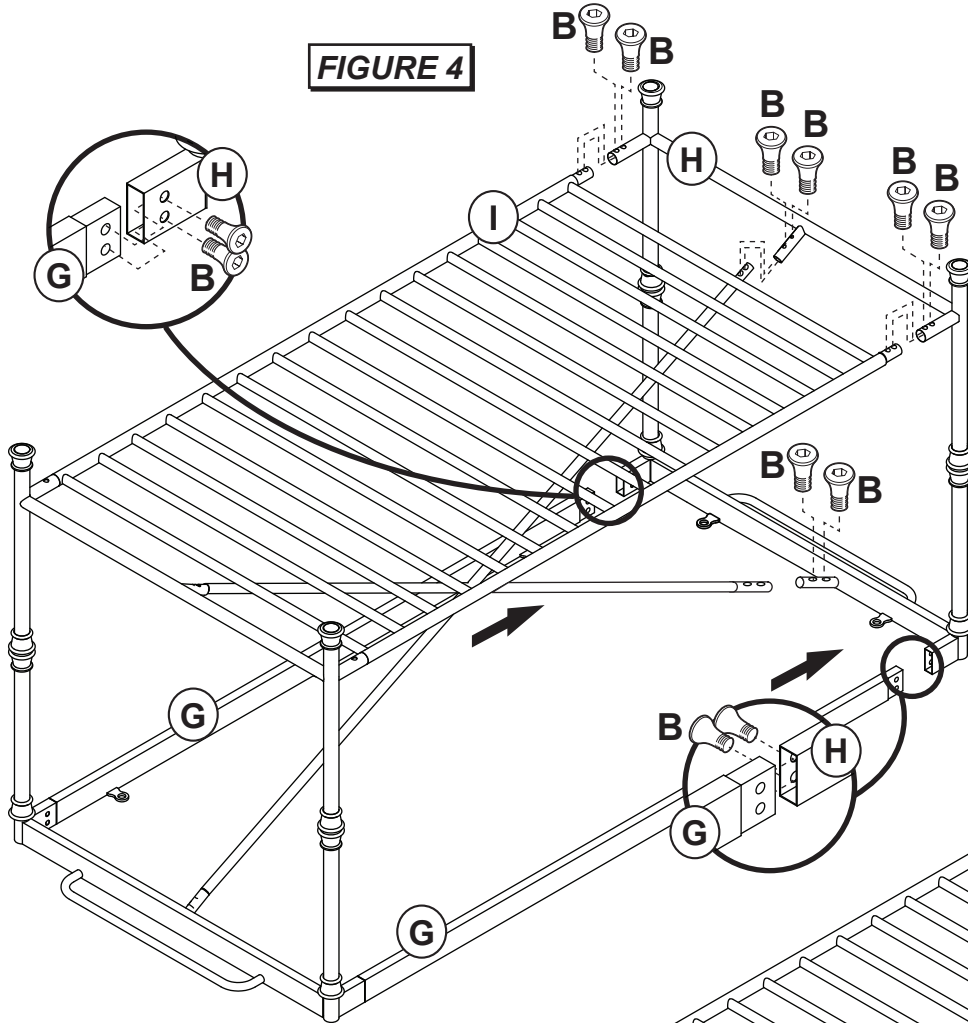

FIGURE 3

STEP 3 - Figure 3

Next insert Bottom Shelf (I) onto Leg Panel (H) and secure each end with 2 Sunk Bolts (B). Do not fully tighten bolts for this step.

FIGURE 4



STEP 4 - Figure 4

Repeat steps 1-3 to attach the remaining Leg Panel (H) to the assembly. Tighten all bolts with Allen Wrench (E).

STEP 5 - Figure 5

Finally, place Top (F) upside down on a clean smooth surface to prevent from scratching. Attach bottom assembly to Top (F) using 10 Allen Bolts (A), 10 Spring Washers (C) and 10 Flat Washers (D). Tighten bolts with Allen Wrench (E) provided. Turn table to upright position. The assembly is now complete.

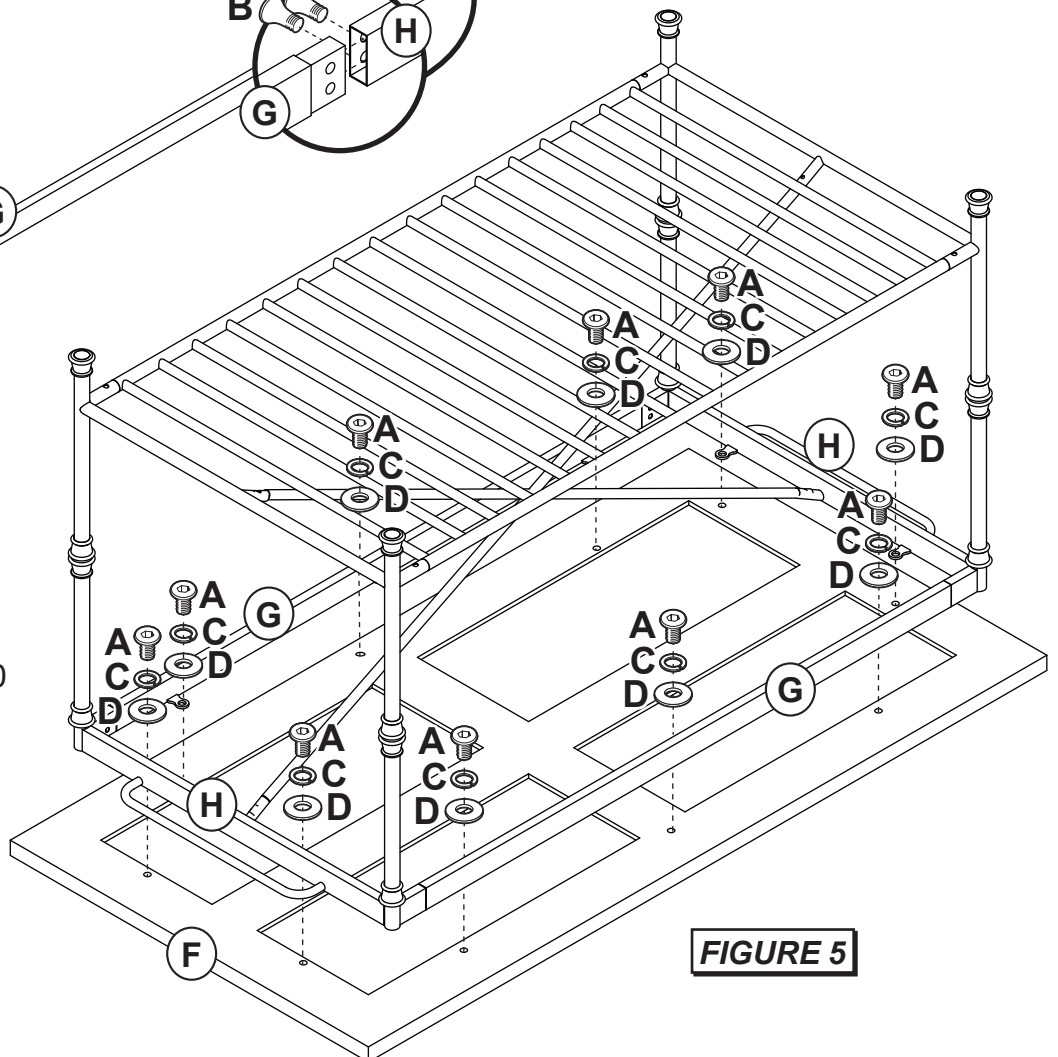

FIGURE 5