

# MAESTRALE 10 UNDER CABINET RANGE HOOD



**A NEW CHOICE IN PROFESSIONAL UNDER CABINET HOODS.** The new Maestrale by Faber is a 10" tall, 23" deep under cabinet wall hood with a 600 CFM Pro all metal blower housing and impellers. With baffle style grease filters, top or direct rear venting, welded, wrapped and polished corners and a 3 speed control, this unbranded hood can be mixed and matched with any cooking brand.



## AVAILABLE MODELS

Model #	Size / Color	Motor Class (CFM)	Sound Levels (sones)
MAES3010SS600-B	30 Stainless	600 CFM	2.8 - 7.5 sones
MAES3610SS600-B	36 Stainless	600 CFM	2.8 - 7.5 sones
MAES4210SS600-B	42 Stainless	600 CFM	2.8 - 7.5 sones

## KEY FEATURES



### Pro Motor

The motor in this hood is surrounded in metal with all metal impellers for top performance



### Adjustable Mounting Hardware

Wall brackets are adjustable once the hood is hung to insure a perfect level installation

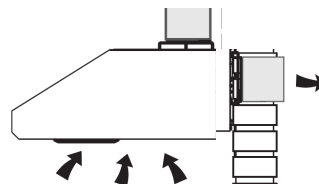

### Direct Rear Venting

Vent the ducting up or rotate the blower to the back to avoid extra duct work when on an outside wall



### Baffle Grease Filters

Dishwasher safe SS metal filters capture grease and allow for easy clean up in the dishwasher

# MAESTRALE 10 UNDER CABINET RANGE HOOD



## SPECIFICATIONS

## DIMENSIONS

depth / height	23" d / 10" h
convertible to ductless	yes - kit sold separately
controls	3 speed slider w/ led indicator
lighting	2 (30") or 3 (36", 48") x 5 (w) led
ducting top / rear (Vari-Duct)	6" round (top or back)
grease filters	dishwasher safe stainless steel baffle
pro motor with metal impellers	yes
ac power	350 watts / 2.9 amps

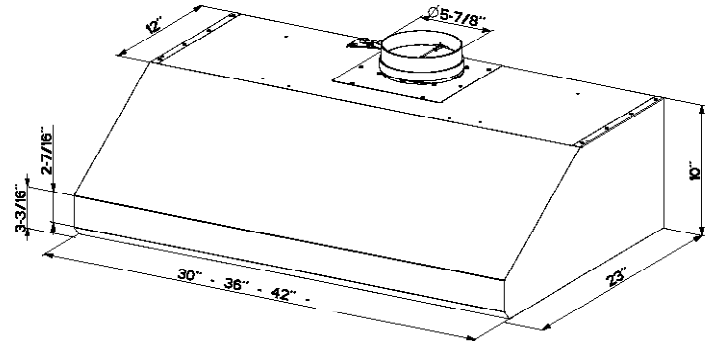

Front View

## PERFORMANCE

SPEED	1	2	3
CFM	180	380	560
Sones	2.8	4.5	7.5

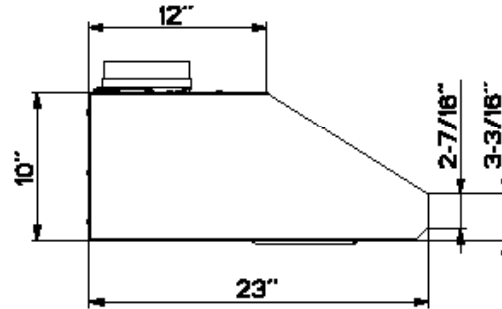

Side View

## ACCESSORIES

### # MUDAMPER6 / MUDAMPER8 - Universal Make-Up Air Damper

Satisfies make-up air requirements, this kit uses an air switch to activate the make-up air damper to open and bring fresh air into the home when the hood fan is on. It then closes tightly when the hood is off. The CFM level is not reduced with this accessory.

### # DUCTGRT30 / DUCTGRT36 - Ductless Vent Grate Kit

A 4" tall stainless steel vent grate which is installed between the hood & the cabinet to recirculate the air back into the kitchen when ducting outside isn't possible. Includes the vent grate, hardware and charcoal filters.

### # FILTER1 - Replacement Charcoal Filter Kit

High quality charcoal filter for use when recirculating the air back into the kitchen. Filters out odor and should be replaced every 6 months

### # TELEMAES Telescopic Chimney Cover

24" wide, extends to accommodate 8 - 9 foot ceilings

### # FULL30 / FULL36 / FULL42 Full Width Duct Cover

12" high, extends full width of the hood

### # CFMRED CFM Reducer Kit

For use in make up air environments where an under 300 cfm hood is required. This kit reduces the ducting to 5" round and reduces the cfm to under 300.

### # FILTER1LL - Long Lasting Charcoal Filter Kit

New washable charcoal filter can be recharged and washed up to 8 times. For use when recirculating the air back into the kitchen. Filters out odor and can last up to 4 years.

### # CFMRED2 CFM Reducer Kit\*

For use in make up air environments where an under 400 cfm hood is required. This kit reduces the ducting to 5" round and reduces the cfm from 400 to under.

WARNING! Product specifications are subject to change without notification. Consult the installation instructions before you begin installing this range hood. \* Check local make up air codes for guidelines.

