



3X LAYER MESH FILTER



LED LIGHT

ELICA'S EXCLUSIVE PLUS FEATURES

Potenza combines curved glass and stainless steel to create a light and airy environment, which is perfect for any contemporary kitchen.

The flowing designs of 30" or 36" widths come with a powerful 400 CFM blower that can support the cooking demands of most kitchens. Backlit push button controls manage multiple functions, including LED lighting and 3 speed blower. Potenza also features a telescopic chimney for up to 8' 5" ceilings.

Designed for standard ducted installation, Potenza can also be installed as a recirculating system using the kit available as an accessory.

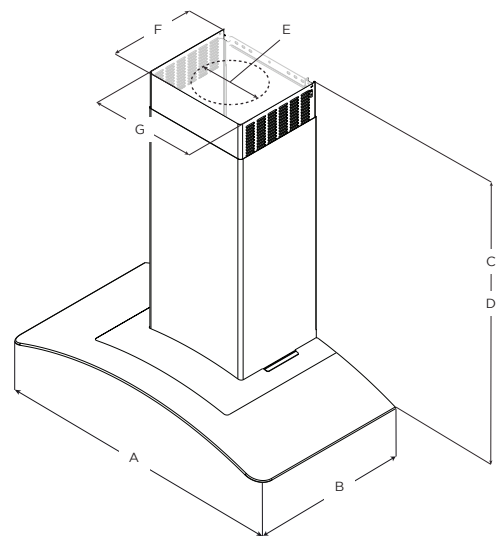

≥24"





≥30"

MOUNTING HEIGHT RANGE

	Models	
	EPT430S2	EPT436S2
A	30" (76.2 cm)	36" (91.4 cm)
B	19 ¹ / ₈ " (50 cm)	
C*	Max: 36 ⁵ / ₈ " (93 cm) Min: 24" (61 cm)	
D**	Max: 32 ³ / ₈ " (83.3 cm) Min: 20 ³ / ₈ " (51.7 cm)	
E	6" (15.24 cm)	
F	10 ³ / ₄ " (27.3 cm)	
G	13 ¹ / ₂ " (33.2 cm)	

* Ductless (Recirculating) version

** Ducted version

SPECIFICATIONS	c  	
	30" UNIT	36" UNIT
Model:	EPT430S2	EPT436S2
Dimensions:	30 "W x 19 5/8"D x 1 15/16"H	36"W x 19 5/8"D x 1 15/16"H
Blower Type(internal):	400 CFM	
Blower Performance:		
Speed 1	160 CFMs	
Speed 2	280 CFMs	
Speed 3	400 CFMs	
Noise (sones): Working Speed	Min: 0.91, Max: 5.9 Sones	
Finish:	Stainless Steel	
Controls:	Backlit Push Button	
Illumination:	2 LED	
Filter Type:	Dishwasher-Safe, Aluminum Mesh Grease Filters	
Duct Transition:	Round 6"/150cms	
Installation Type:	Ducted, Recirculating kit sold separately	
Electrical:	120 Volts, 60 Hertz, 300 Watts, 2.5 Amps	
KITS:		
Optional Recirculating Kit	KIT0102875	
Optional Long Chimney Extension	KIT0100315	
Optional CFM Reduce Kit	KIT02748	

PLUS FEATURES



3X LAYER GREASE FILTER - Elica aluminum mesh filters are a step above competition, featuring triple layered, anodized aluminum that is woven into a highly dense mesh. The thick mesh captures more grease, anodization helps resist staining and provides durability to repeated cleanings in the dishwasher.



LED LIGHT - LED lighting is undoubtedly the smartest solution in terms of energy saving. Expected life time of over 20.000 hours, represents the most remarkable advantage of LED light bulbs.