



Charcoal Side Features:

- Adjustable fuel tray
- 600 sq. in. cooking area
- For use with charcoal or wood chips
- Adjustable dampers for controlling air flow

Gas Grill Features:

- Two high performance Coyote iBurners™
- 600 sq. in. cooking area
- Up to 40,000 BTU
- Complete 304 stainless steel construction
- Interior grill lighting
- Integrated wind guard

Dimensions:

- Cutout: (H) 12 1/2" X (W) 47 3/4 X (D) 20 1/2"
- Overall: (H) 25 1/2" X (W) 50" X (D) 25 1/2"

Accessories:

- Laser-Cut Signature Grates (CSIGRATE12)
- 14" stainless steel griddle (C1GRDL)
- Stainless steel cart available
- Custom fit, weather resistant cover
- Gas conversion kit

C1HY50 SPECS

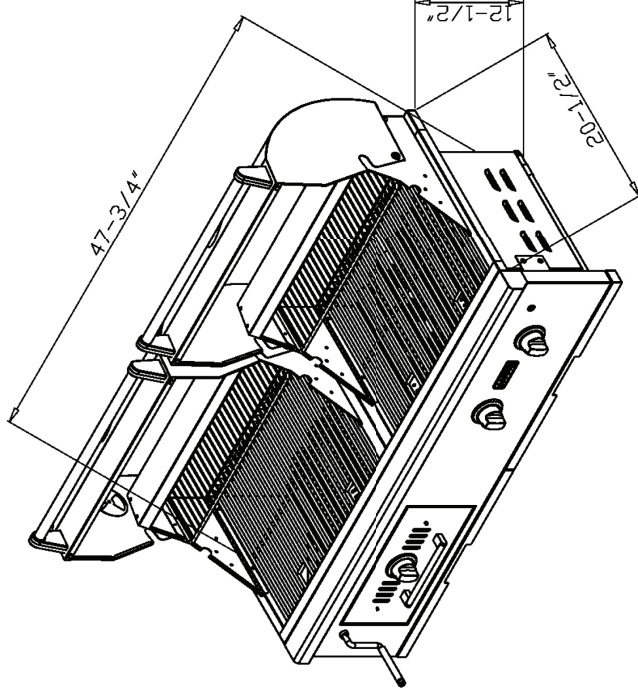
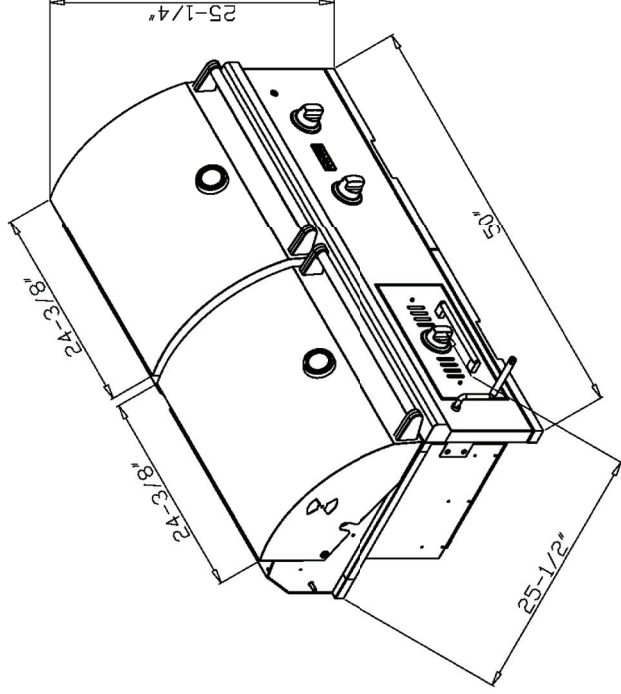

COYOTE
Outdoor Living

www.coyoteoutdoor.com