

---

# INSTALLATION INSTRUCTIONS

---

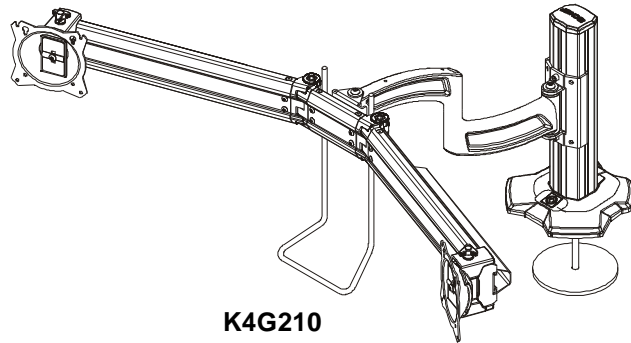

**K4G210**

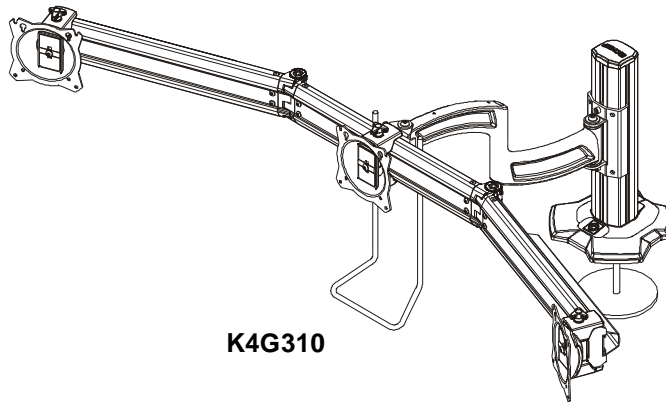

**K4G310**

---

## Kontour™ Articulating Array Arm Grommet Series

---

## DISCLAIMER

Milestone AV Technologies and its affiliated corporations and subsidiaries (collectively "Milestone"), intend to make this manual accurate and complete. However, Milestone makes no claim that the information contained herein covers all details, conditions or variations, nor does it provide for every possible contingency in connection with the installation or use of this product. The information contained in this document is subject to change without notice or obligation of any kind. Milestone makes no representation of warranty, expressed or implied, regarding the information contained herein. Milestone assumes no responsibility for accuracy, completeness or sufficiency of the information contained in this document.

Chief® is a registered trademark of Milestone AV Technologies. All rights reserved.



**WARNING:** Never operate this mounting system if it is damaged. Return the mounting system to a service center for examination and repair.



**WARNING:** Do not use this product outdoors.

**--SAVE THESE INSTRUCTIONS--**



## IMPORTANT SAFETY INSTRUCTIONS



**WARNING:** A WARNING alerts you to the possibility of serious injury or death if you do not follow the instructions.



**CAUTION:** A CAUTION alerts you to the possibility of damage or destruction of equipment if you do not follow the corresponding instructions.



**WARNING:** Failure to read, thoroughly understand, and follow all instructions can result in serious personal injury, damage to equipment, or voiding of factory warranty! It is the installer's responsibility to make sure all components are properly assembled and installed using the instructions provided.



**WARNING:** Failure to provide adequate structural strength for this component can result in serious personal injury or damage to equipment! It is the installer's responsibility to make sure the structure to which this component is attached can support five times the combined weight of all equipment. Reinforce the structure as required before installing the component.



**WARNING:** Exceeding the weight capacity can result in serious personal injury or damage to equipment! It is the installer's responsibility to make sure the combined weight of all components located on the K4G210-310 mounts up to (and including) the display does not exceed 15 lbs (6.8 kg) per display.







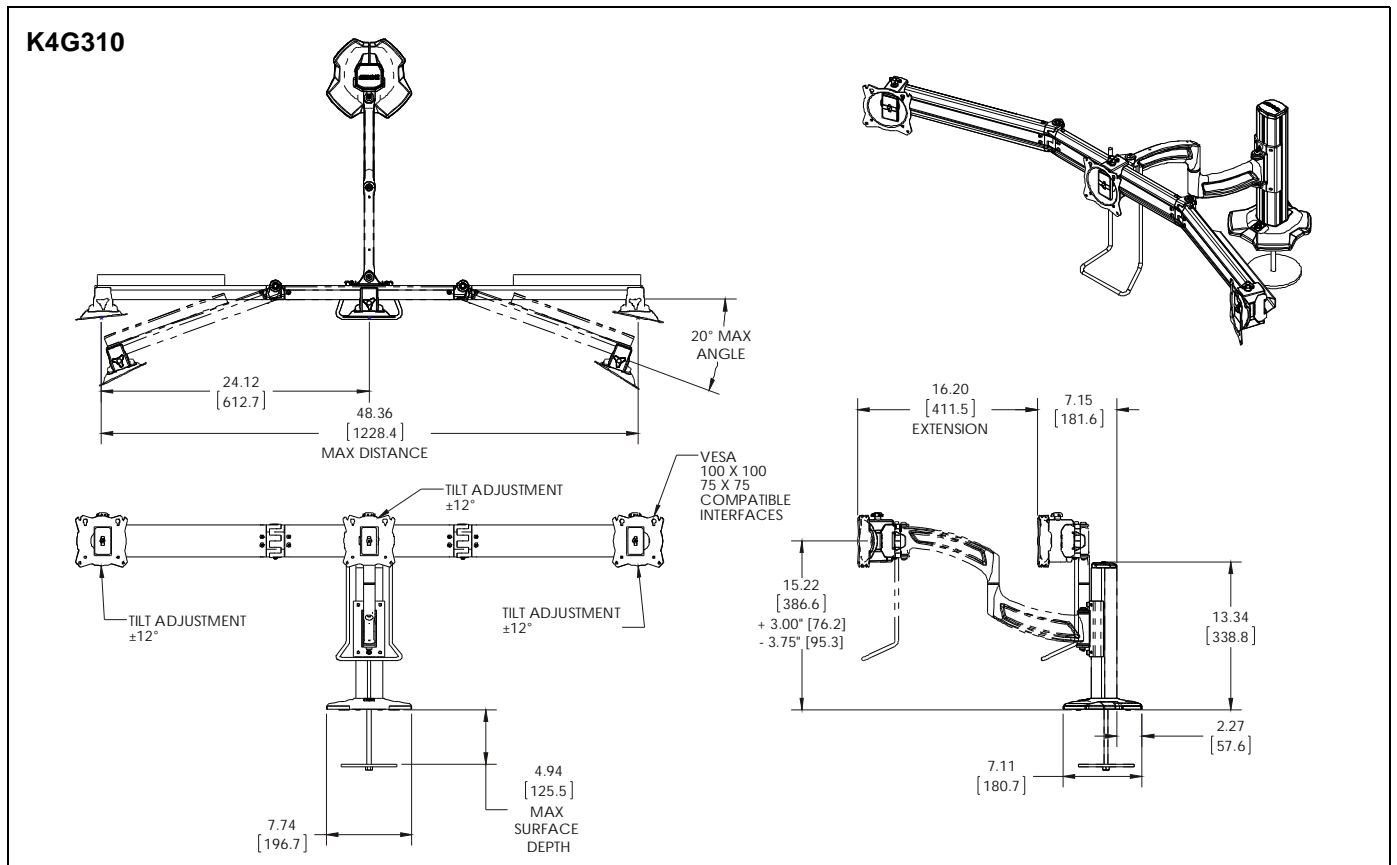
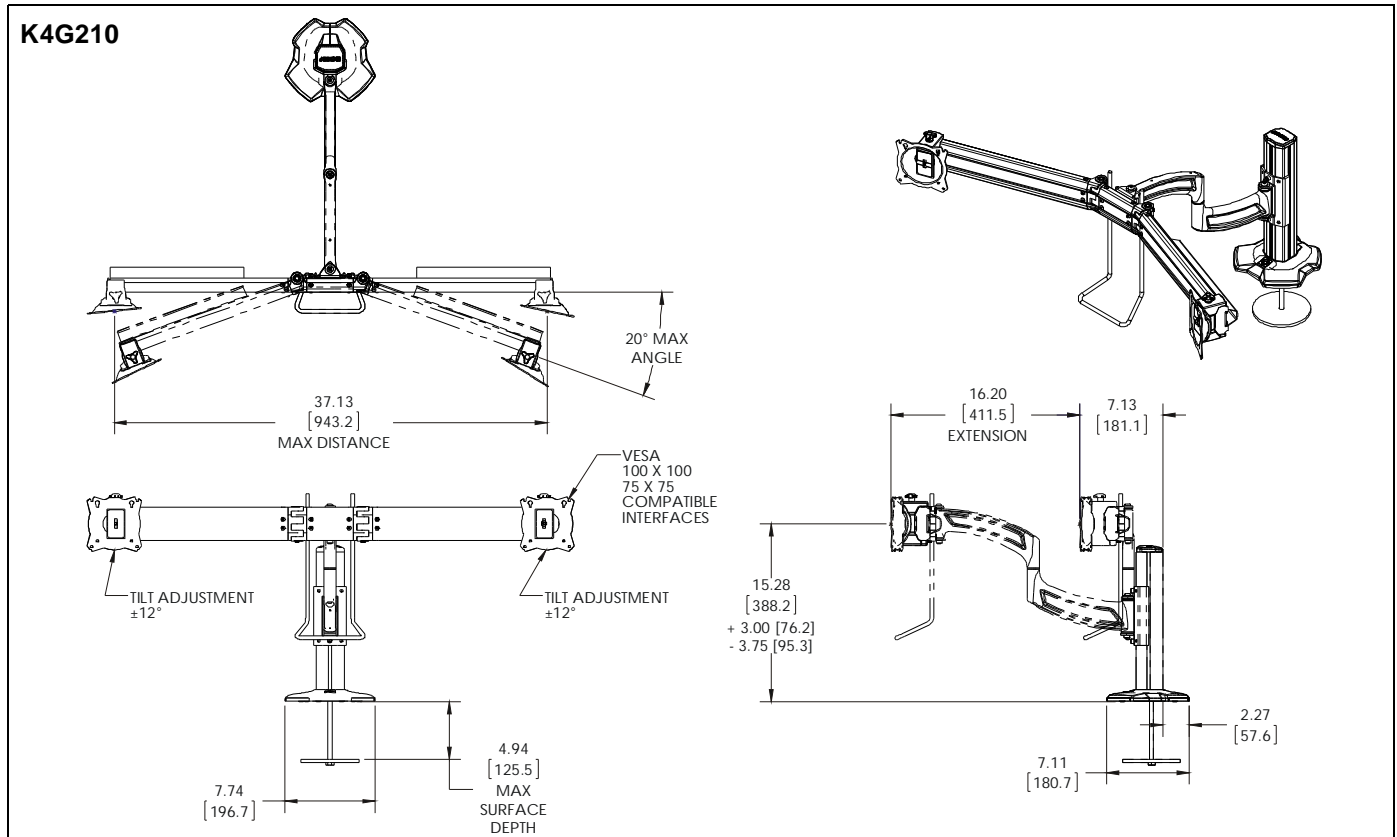





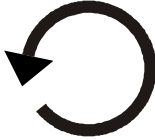

**WARNING:** Use this mounting system only for its intended use as described in these instructions. Do not use attachments not recommended by the manufacturer.

**DIMENSIONS**



## LEGEND

	<b>Tighten Fastener</b> Apretar elemento de fijación Befestigungsteil festziehen Apertar fixador Serrare il fissaggio Bevestiging vastdraaien Serrez les fixations		<b>Pencil Mark</b> Marcar con lápiz Stiftmarkierung Marcar com lápis Segno a matita Potloodmerkteken Marquage au crayon
	<b>Loosen Fastener</b> Aflojar elemento de fijación Befestigungsteil lösen Desapertar fixador Allentare il fissaggio Bevestiging losdraaien Desserrez les fixations		<b>Drill Hole</b> Perforar Bohrloch Fazer furo Praticare un foro Gat boren Percez un trou
	<b>Phillips Screwdriver</b> Destornillador Phillips Kreuzschlitzschraubendreher Chave de fendas Phillips Cacciavite a stella Kruiskopschroevendraaier Tournevis à pointe cruciforme		<b>Adjust</b> Ajustar Einstellen Ajustar Regolare Afstellen Ajuster
	<b>Open-Ended Wrench</b> Llave de boca Gabelschlüssel Chave de bocas Chiave a punte aperte Steeksleutel Clé à fourche		<b>Remove</b> Quitar Entfernen Remover Rimuovere Verwijderen Retirez
	<b>By Hand</b> A mano Von Hand Com a mão A mano Met de hand À la main		<b>Optional</b> Opcional Optional Opcional Opzionale Optie En option
	<b>Hex-Head Wrench</b> Llave de cabeza hexagonal Sechskantschlüssel Chave de cabeça sextavada Chiave esagonale Zeskantsleutel Clé à tête hexagonale		<b>Security Wrench</b> Llave de seguridad Sicherheitsschlüssel Chave de segurança Chiave di sicurezza Veiligheidsleutel Clé de sécurité

**TOOLS REQUIRED FOR INSTALLATION**

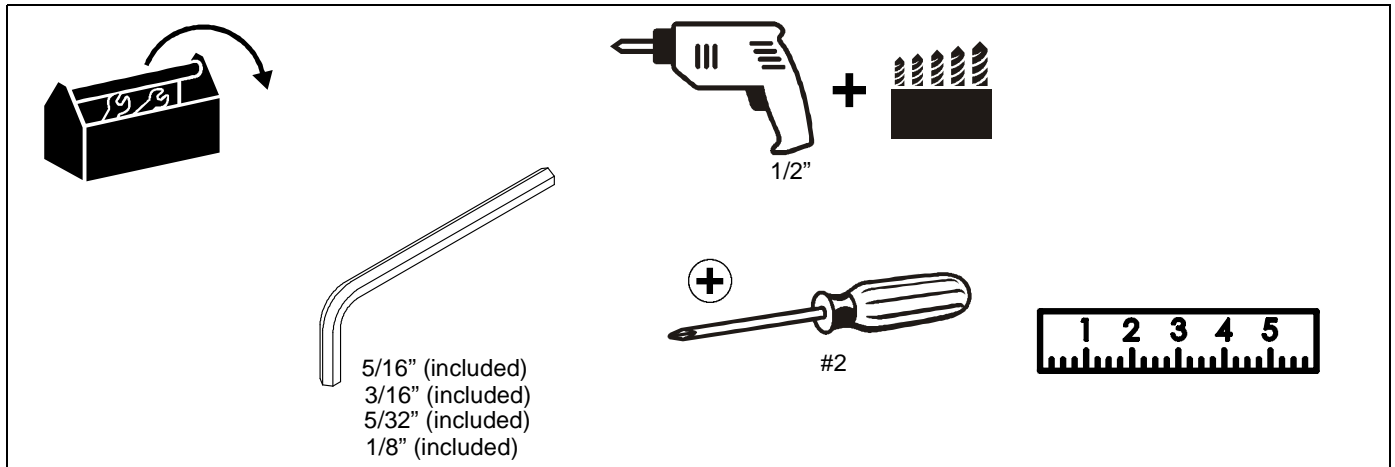

**PARTS**

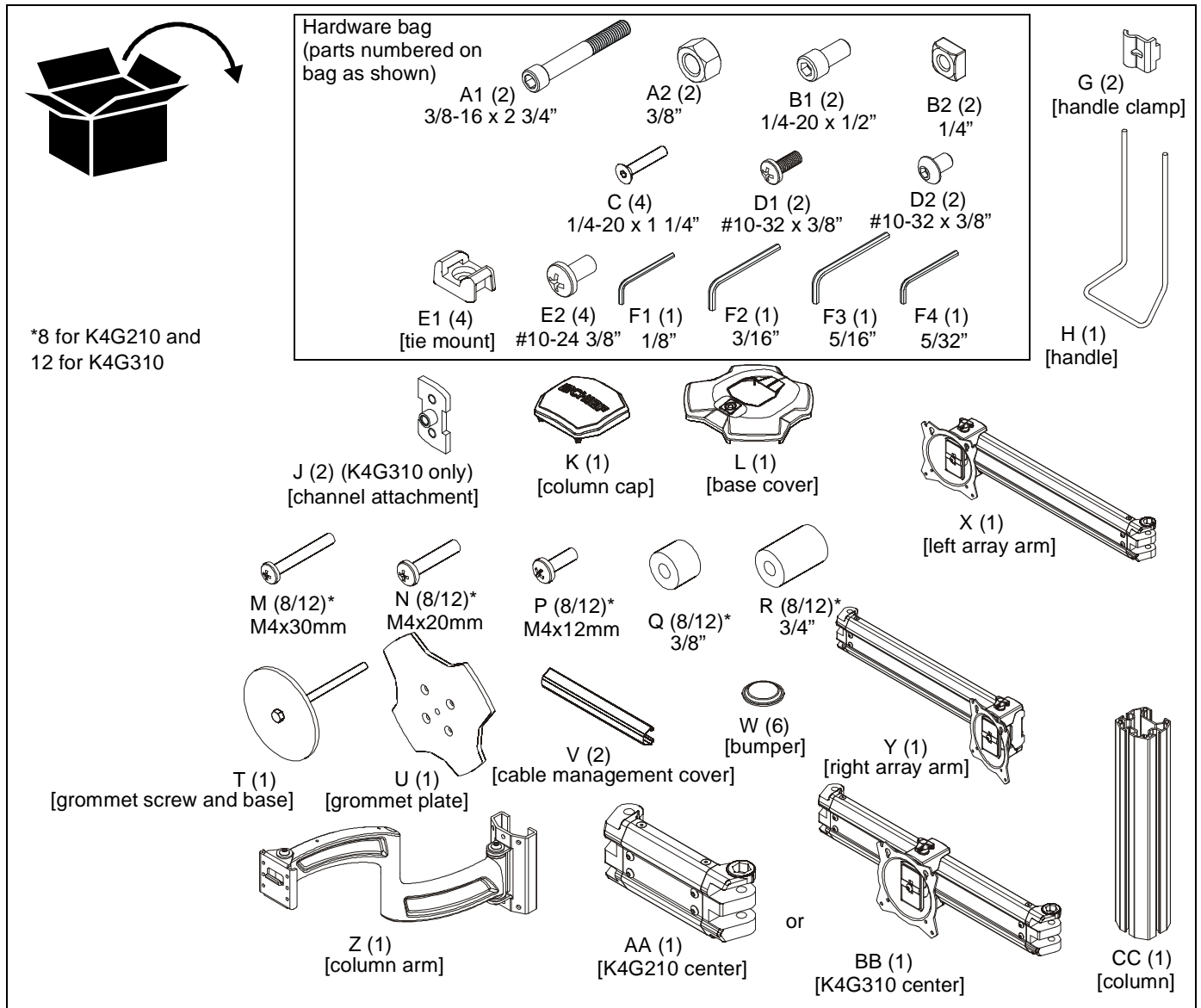

### Assembly And Installation

1. Use four 1/4-20 x 1 1/4" flat head cap screws (C) to secure grommet plate (U) to column (CC). Make sure longer legs of grommet plate are aligned with the front of column. (See Figure 1)

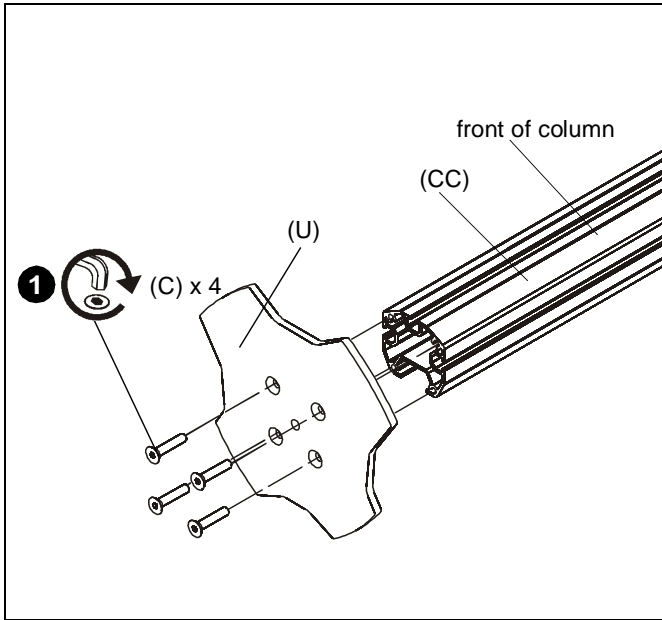

Figure 1

2. Apply bumpers (W) to underside of grommet plate (U). (See Figure 2)

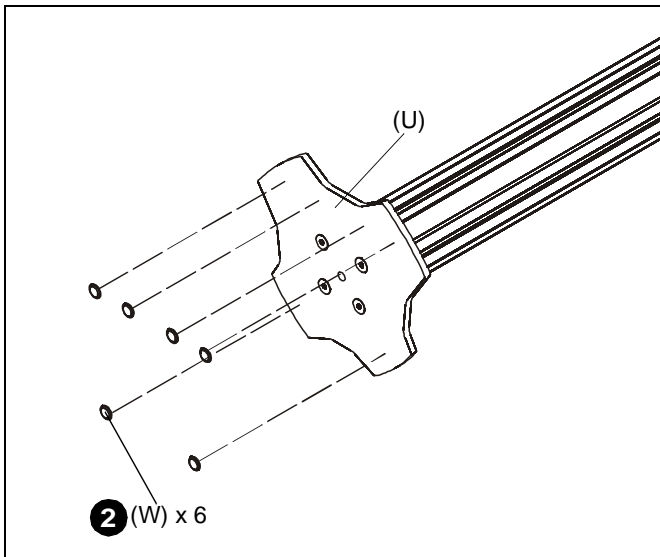

Figure 2

3. Locate a flat surface (thickness minimum of 1" to maximum of 5") on which to mount the array assembly.
4. If a hole doesn't already exist, drill a hole in desk with a diameter between 1/2" and 3 1/2" at desired mounting location. (See Figure 3)
5. Position mount on desk so that center hole of grommet plate (U) is centered over grommet hole. (See Figure 3)

6. Insert grommet screw (T) through grommet hole and thread into center hole of grommet plate (U). (See Figure 3)
7. Tighten grommet screw (T) until grommet base is tightened against underside of desk and mount is securely mounted to desk. (See Figure 3)

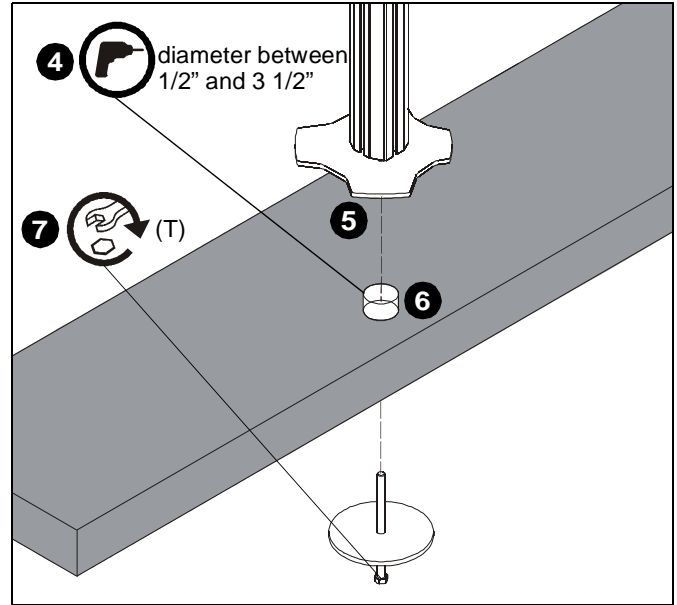

Figure 3

8. Carefully manipulate base cover (L) to create an opening large enough to wrap cover around array column. (See Figure 4)
9. Wrap base cover (L) around column and slide it down until base cover fits securely onto grommet plate (U). (See Figure 4)

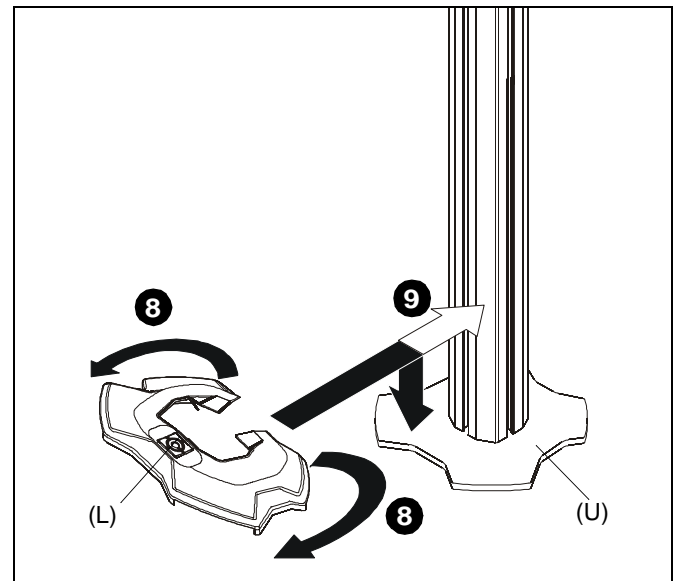

Figure 4

10. Loosely install two 1/4-20 x 1/2" socket head carriage screws (B1) through mounting holes on column arm (Z) bracket and into 1/4" square nuts (B2). (See Figure 5)
11. Slide column arm (Z) bracket into column (CC) until desired mounting height is reached. (See Figure 5)

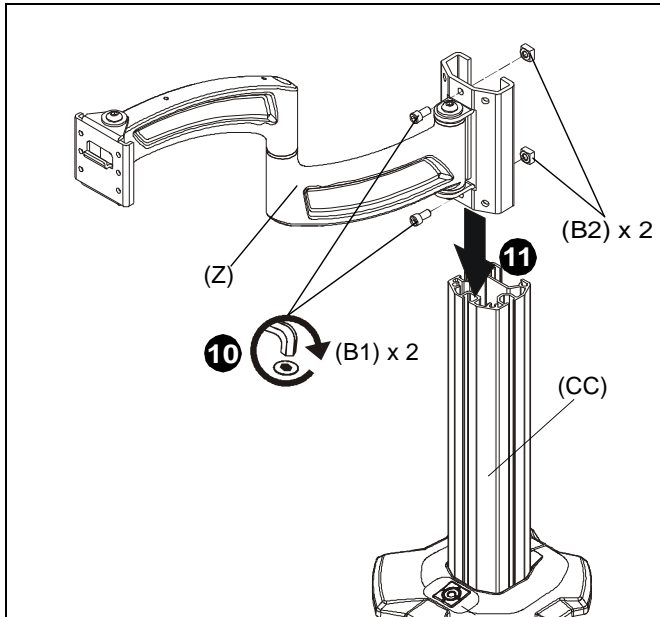

Figure 5

12. Tighten two 1/4-20 x 1/2" socket head carriage screws (B1) to secure column arm (Z) at desired height. (See Figure 6)
13. Install column cap (K) to column (CC). (See Figure 6)

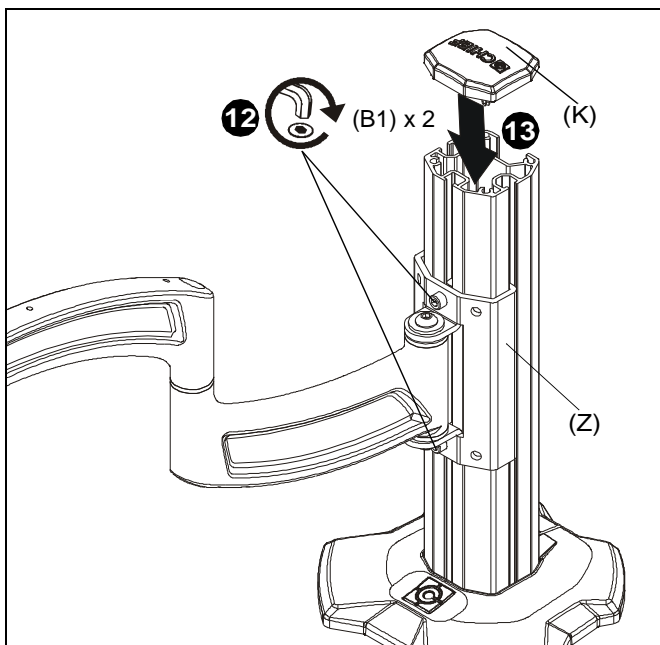

Figure 6

14. Use two 3/8-16 x 2 3/4" socket head carriage screws (A1) and two 3/8" lock nuts (A2) to secure left array arm (X) and right array arm (Y) to array center (AA or BB). (See Figure 7)

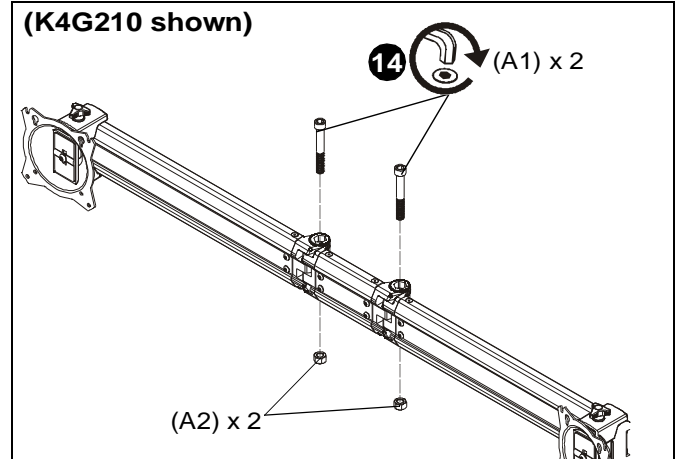

Figure 7

15. Hang array center (AA or BB) onto column arm (Z) faceplate. (See Figure 8)

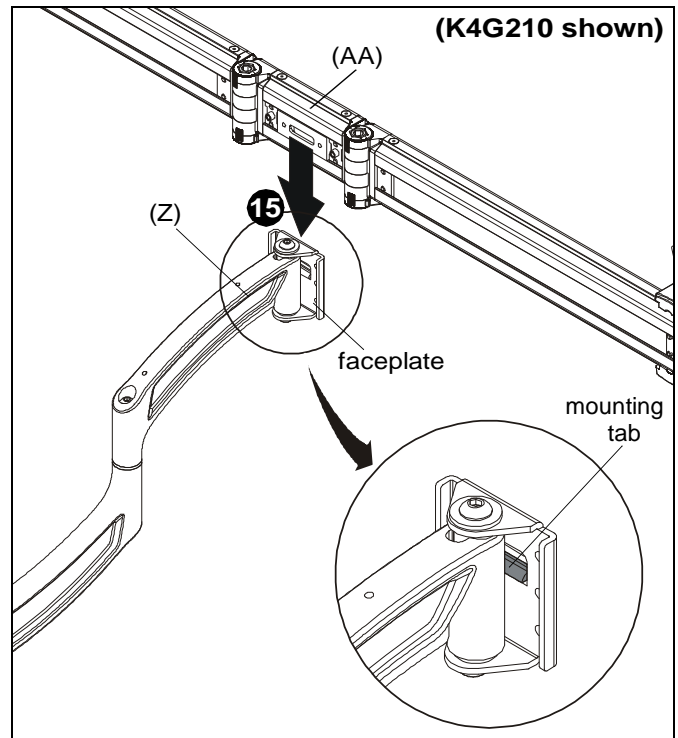

Figure 8

16. Use two #10-32 x 3/8" button head cap screws (D2) to secure column arm (Z) to array center (AA or BB). (See Figure 9)

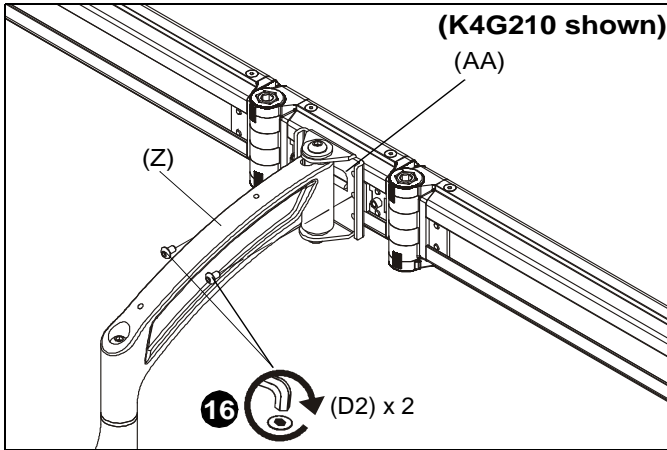

Figure 9

- 17. (K4G310 only) Insert two channel attachments (J) into back of array center (BB). Attachments must be turned horizontally in order to fit into channel. (See Figure 10)

**NOTE:** Channel attachments are already pre-installed on K4G210. Proceed ahead to step 20 if installing K4G210.

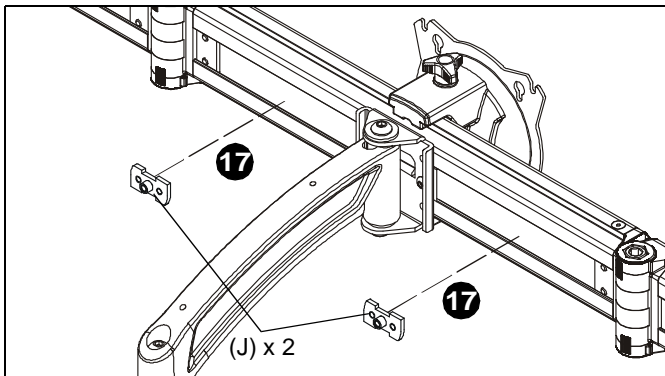

Figure 10

- 18. (K4G310 only) Rotate channel attachments (J) 90° clockwise. (See Figure 11)
- 19. (K4G310 only) Slide channel attachments (J) toward arm assembly (Z) to prepare for handle installation. (See Figure 11)

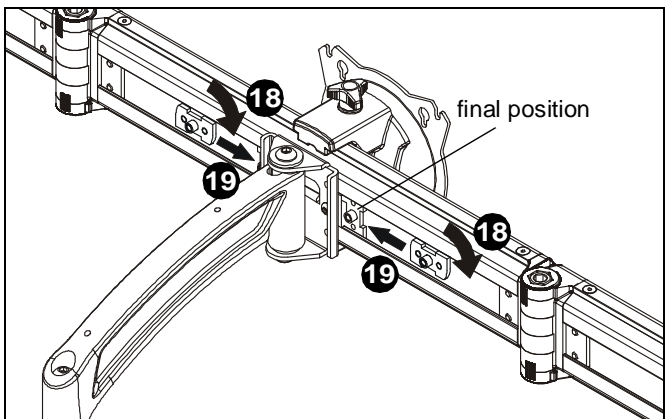

Figure 11

- 20. Use two #10-32 x 3/8" Phillips pan machine screws (D1) and two handle clamps (G) to secure handle (H) to array center (AA or BB). (See Figure 12)

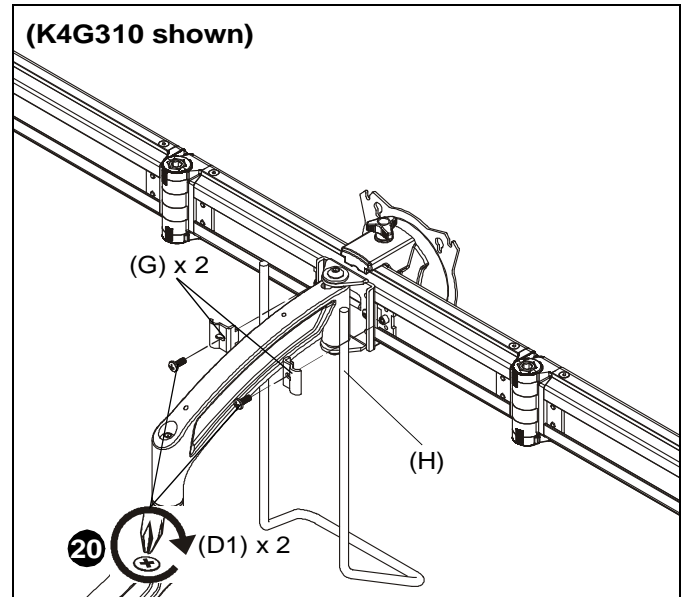

Figure 12

**Display Installation**

**WARNING:** Exceeding the weight capacity can result in serious personal injury or damage to equipment! It is the installer's responsibility to make sure the combined weight of all components located on the K4G210-310 Series mounts up to (and including) the display does not exceed 15 lbs (6.8 kg) per display.

**CAUTION:** Using screws of improper size may damage your display! Proper screws will easily thread into display mounting holes.

**NOTE:** Supplied screws (M, N and P) may not fit properly for all displays. See display's operating instructions for details.

**IMPORTANT ! :** When applicable, always install center display **FIRST** in order to prevent stand from tipping! If there is no center faceplate (K4G210), be sure to support opposite arm when mounting displays to prevent stand from tipping! If possible, mount displays to both sides simultaneously.

**NOTE:** Set height of center display prior to installing other displays. See Height Adjustment Section for details. Center of display must be at least 18" above desk surface.



### Flush Mounting Holes

1. Position faceplate in desired mounting position. Adjust as required before proceeding. See Height Adjustment Section for details.
2. Using Phillips screwdriver, carefully install two M4 x 12mm Phillips pan machine screws (P) into the *upper* mounting holes on the display. Thread screws completely into display, then back out 3 complete turns. (See Figure 13)

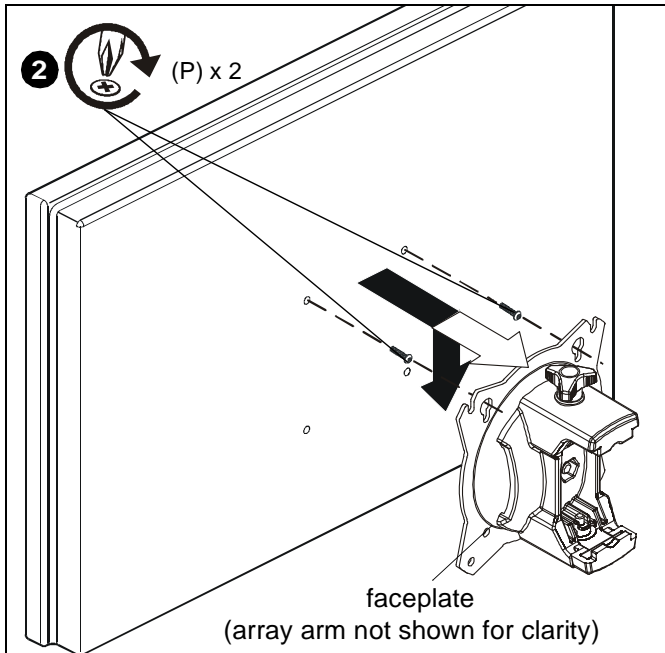

Figure 13

3. Pick up and align display so that screws (P) (installed on the back of the display in the previous step) fit into the mounting holes on the faceplate. Lower the display firmly into place. (See Figure 13)
4. Using Phillips screwdriver, install two M4x12 mm Phillips pan machine screws (P) through the *lower* mounting holes on faceplate into the display. (See Figure 14)

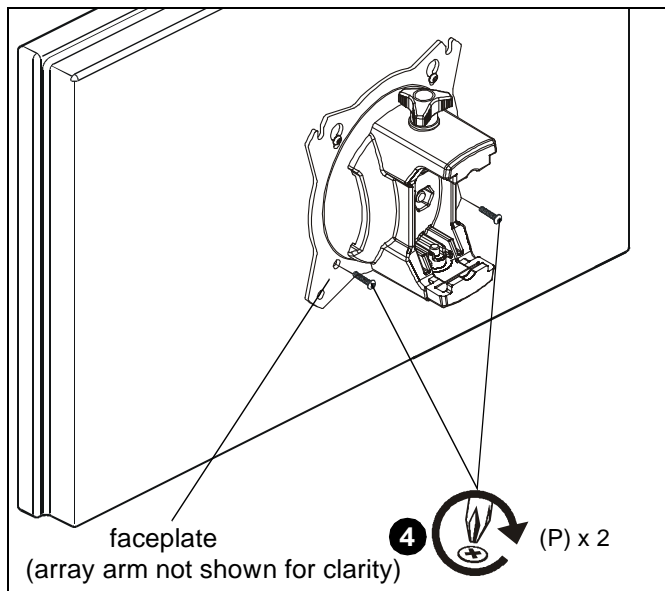

Figure 14

5. Tighten all four screws (P). Do not over-tighten!

**NOTE:** If roll adjustment is desired for center faceplate, do not tighten screws.

6. Repeat Steps 1-5 for other displays.
7. Proceed to Cable Management Section.

### Recessed Mounting Holes

**NOTE:** If faceplate does not fit into recessed area of display, proceed with the steps in this section.

1. Determine depth of recessed mounting holes relative to back surface of display (against which faceplate will contact).
2. Select proper length spacer and screw from table below:

**NOTE:** All spacers used should be the same length. If the recess depths result in multiple spacer lengths, then select the longer spacer.

IF recess DEPTH is:	THEN use spacer:	AND screw:
3/8" or less	Q (3/8" long)	N (M4 x 20mm)
More than 3/8" up to and including 3/4"	R (3/4" long)	M (M4 x 30mm)



**CAUTION:** Using screws of improper size may damage your display! Proper screws will easily and completely thread into display mounting holes.

3. Using Phillips screwdriver, carefully install two selected screws (N or M) through selected spacers (Q or R) into the *upper* mounting holes on the display. Thread screws completely into display, then back out 3 complete turns. (See Figure 15)
4. Pick up and align display so that screws (N or M) (installed on the back of the display in the previous step) fit into the mounting holes on the faceplate. Lower the display firmly into place. (See Figure 15)

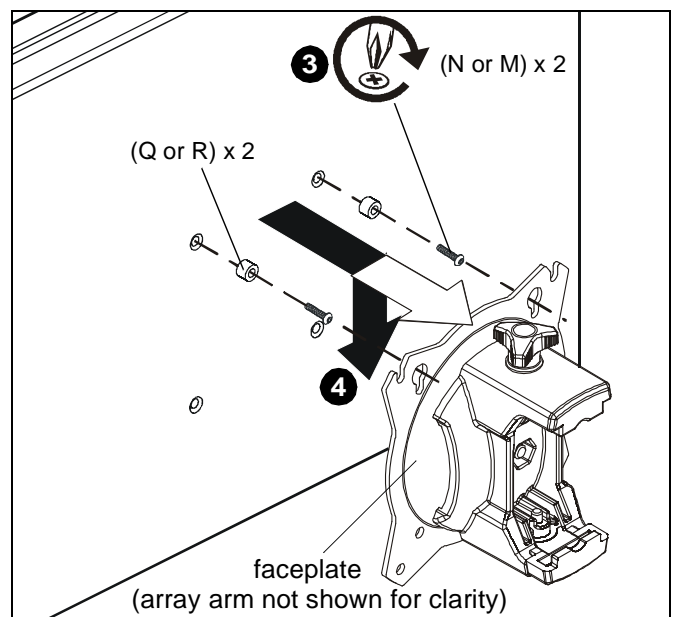

Figure 15

5. Slide two remaining selected spacers (Q or R) in between faceplate and display, positioning them over the *lower* two mounting holes. (See Figure 16)
6. Install two remaining selected screws (N or M) through *lower* two mounting holes on faceplate, selected spacers (Q or R) into the *lower* mounting holes on the display. (See Figure 16)

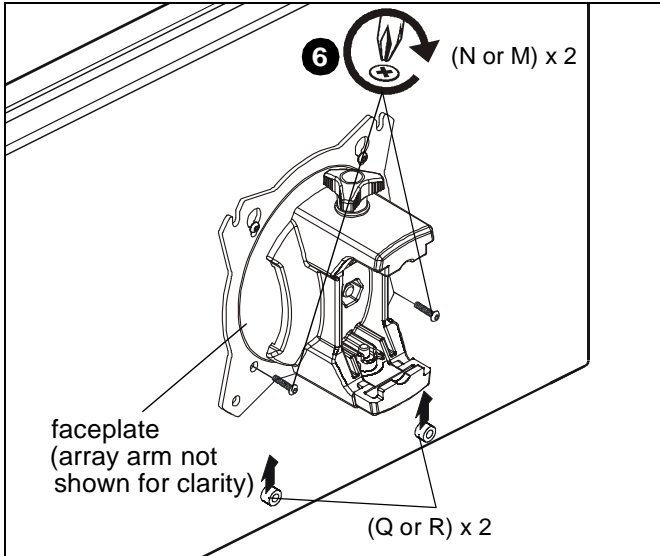

Figure 16

7. Tighten all four screws. Do not over-tighten!

### Adjustments

#### Pivot Adjustment (Array Arm)

1. Array arms may pivot toward the front of mount up to 20° per arm. (See Figure 17)
2. When arms are at desired pivot position, lock pivot position by tightening 3/8-16 x 2 3/4" socket head carriage screws (A1) using 5/16" hex key (E5). (See Figure 17)

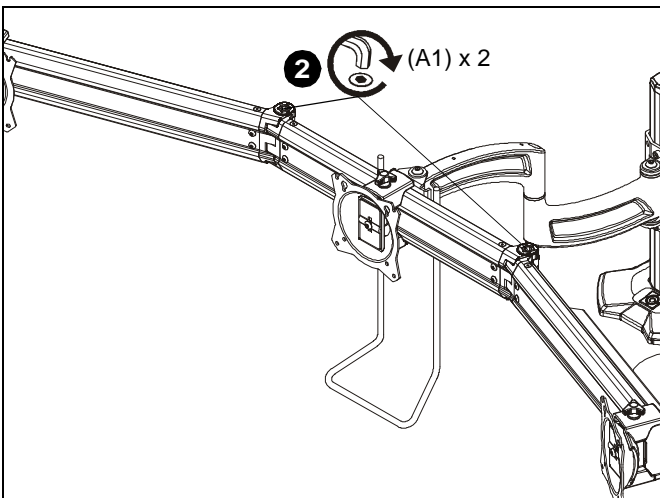

Figure 17

#### Pivot Adjustment (Column Arm)

1. Use handle to extend or collapse column arm (Z) as desired. (See Figure 18)
2. (Optional) Loosen or tighten column arm pivot tension screws as desired to increase or decrease pivot tension. (See Figure 18)

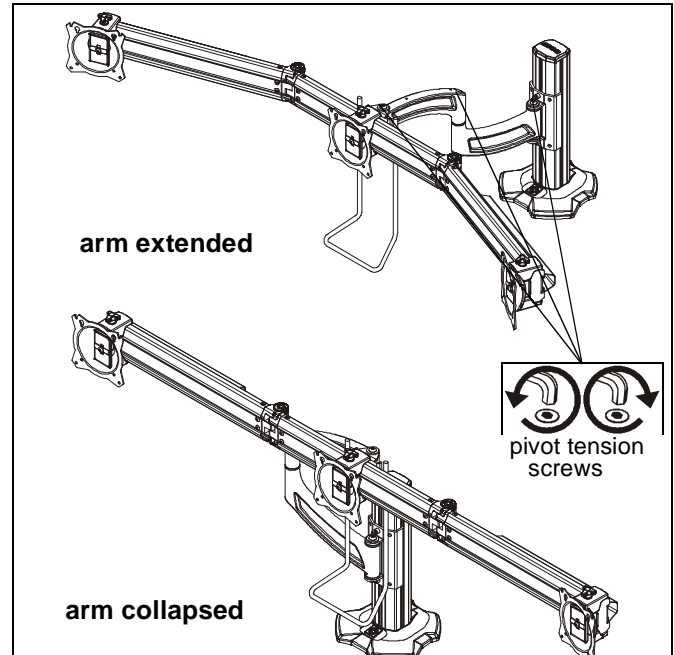

Figure 18

#### Height Adjustment

1. Loosen 1/4-20 x 1/2" socket head carriage screws (B1) holding column arm (Z) to column (CC). (See Figure 19)
2. Adjust column arm to desired height. (See Figure 19)
3. Tighten 1/4-20 x 1/2" socket head carriage screws (B1) to lock column arm's position. (See Figure 19)

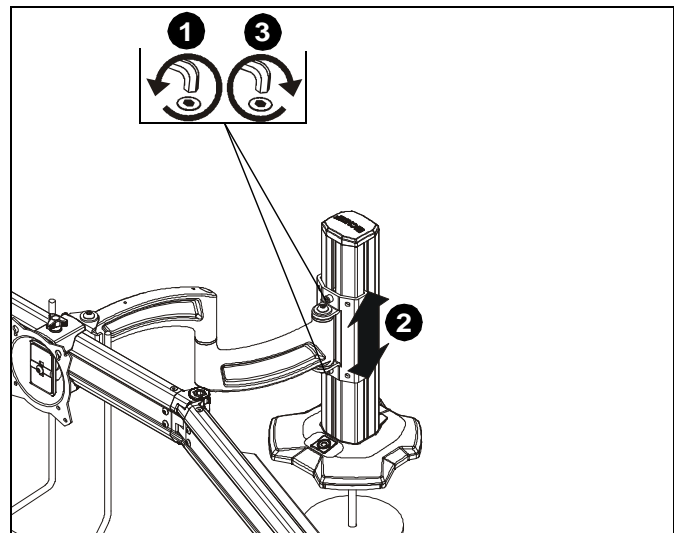
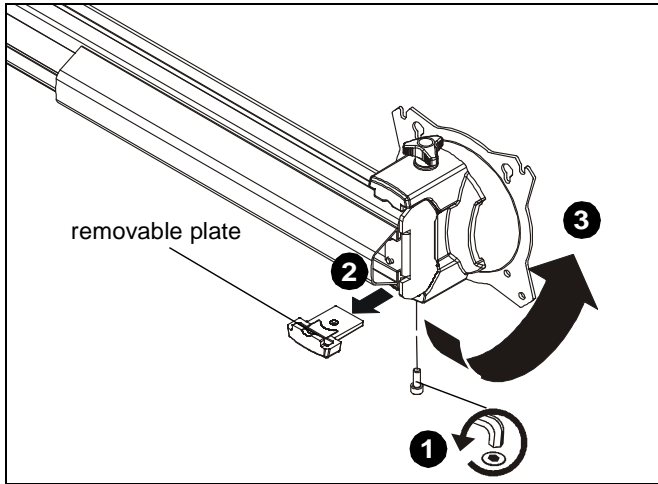

Figure 19

**Faceplate Assembly Removal**

1. Remove hex head bolt from bottom of faceplate assembly. (See Figure 20)
2. Slide out removable plate from bottom of faceplate assembly. (See Figure 20)

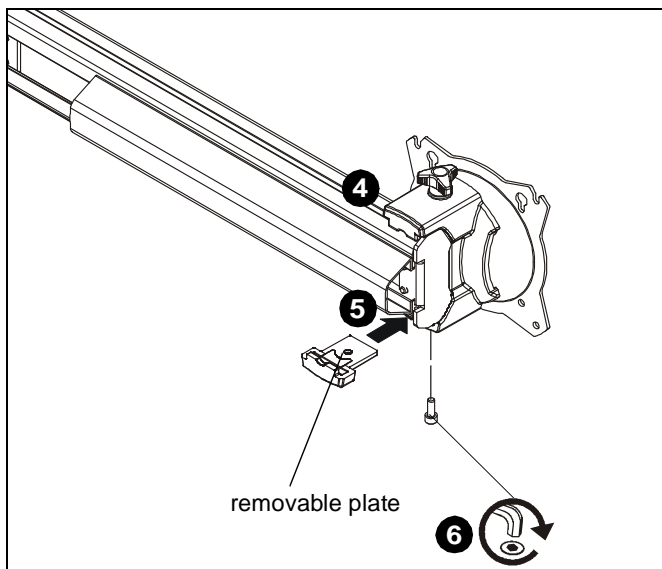

**Figure 20**

3. Remove faceplate assembly from array arm. (See Figure 20)

**To Reattach Faceplate Assembly**

4. Place faceplate assembly on array arm at desired mounting position. (See Figure 21)
5. Slide removable plate back into slot at bottom of faceplate assembly. (See Figure 21)
6. Reinstall hex head bolt removed in Step 1 to secure faceplate assembly to array arm. (See Figure 21)



**Figure 21**

**Lateral Shift**

1. Loosen knob on top of faceplate assembly until faceplate can slide freely along array. (See Figure 22)
2. Adjust lateral position as desired. (See Figure 22)
3. Tighten knob to secure lateral position. (See Figure 22)

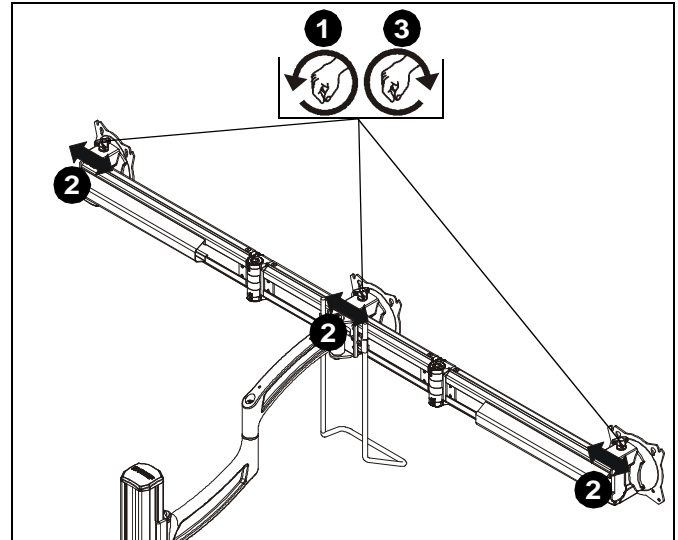

**Figure 22**

**Pitch/Roll/Yaw Adjustment**

1. Loosen knob on top of faceplate assembly. (See Figure 23)
2. Adjust pitch, roll and/or yaw as desired. (See Figure 23)
3. Tighten knob to secure desired faceplate position. (See Figure 23)

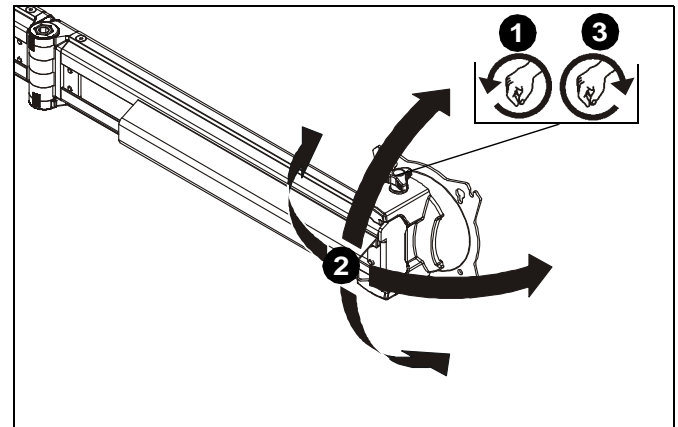

**Figure 23**

**Cable Management**

1. Route cables from display through cable management covers (V) as desired. (See Figure 24)
2. Install cable management covers (V) onto array arms (X and Y). (See Figure 24)

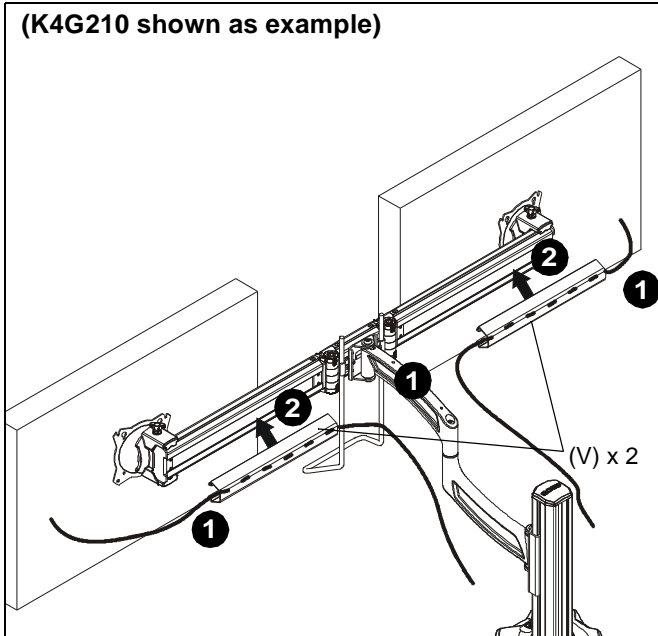

Figure 24

3. Route cables along mounting arms. (See Figure 26)
4. Use cable ties (not included) to secure cables to tie clips (E1). (See Figure 26)

**NOTE:** Leave enough slack in the cables so that arm may still swing without resistance from the cables.

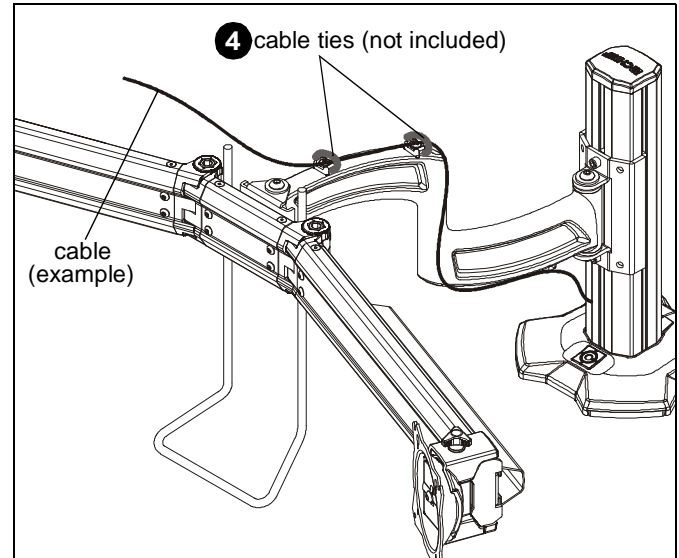

Figure 26

**Cable Management - Clips**

1. Use two #10-24 x 3/8" button head cap screws (E2) to attach two tie mounts (E1) to upper mounting arm. (See Figure 25)
2. Use two #10-24 x 3/8" button head cap screws (E2) to attach two tie mounts (E1) to lower mounting arm. (See Figure 25)

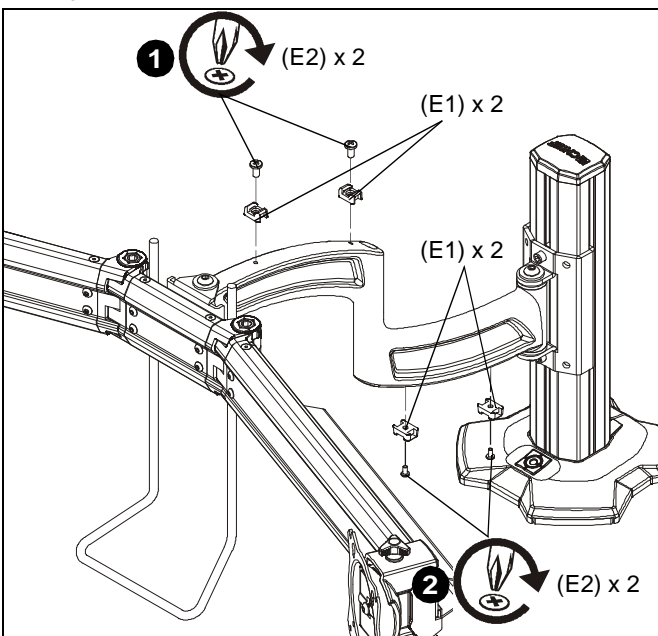

Figure 25









Our Mounts. **Your Vision.**

Chief, a products division of  
Milestone AV Technologies

8800-002371 Rev03  
©2014 Milestone AV Technologies  
[www.chiefmfg.com](http://www.chiefmfg.com)  
04/14

<b>USA/International</b>	<b>A</b> 6436 City West Parkway, Eden Prairie, MN 55344 <b>P</b> 800.582.6480 / 952.225.6000 <b>F</b> 877.894.6918 / 952.894.6918
<b>Europe</b>	<b>A</b> Franklinstraat 14, 6003 DK Weert, Netherlands <b>P</b> +31 (0) 495 580 852 <b>F</b> +31 (0) 495 580 845
<b>Asia Pacific</b>	<b>A</b> Office No. 1 on 12/F, Shatin Galleria 18-24 Shan Mei Street Fotan, Shatin, Hong Kong <b>P</b> 852 2145 4099 <b>F</b> 852 2145 4477

