

ASSEMBLY INSTRUCTIONS
COASTER FINE FURNITURE



Fine Furniture for every stage of life

881571
WRITING DESK

ITEM:881571



ASSEMBLY INSTRUCTIONS

ASSEMBLY TIPS:

1. Remove hardware from box and sort by size.
2. Please check to see that all hardware and parts are present prior to start of assembly.
3. Please follow attached instructions in the same sequence as numbered to assure fast & easy assembly.



WARNING!

1. Don't attempt to repair or modify parts that are broken or defective. Please contact the store immediately.
2. This product is for home use only and not intended for commercial establishments.



ASSEMBLY TIME 80 MINUTES

PARTS IDENTIFICATION







A	TOP PANEL		1PC
B	BOTTOM PANEL		1PC
C	LEFT PANEL		1PC
D	LEFT MIDDLE PANEL		1PC
E	RIGHT MIDDLE PANEL		1PC
F	RIGHT PANEL		1PC

ITEM:881571

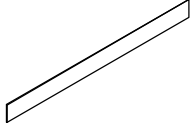
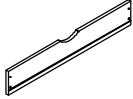
ASSEMBLY INSTRUCTIONS

PARTS IDENTIFICATION

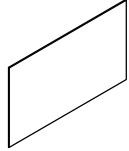



G	BACK PANEL		1PC
H	LARGE DRAWER FRONT PANEL		1PC
I	DRAWER RIGHT PANEL		3PCS
J	DRAWER LEFT PANEL		3PCS
K	LARGE DRAWER BACK PANEL		1PC
L	LARGE DRAWER BOTTOM PANEL		1PC
M	SMALL DRAWER FRONT PANEL		2PCS

ITEM:881571

ASSEMBLY INSTRUCTIONS

PARTS IDENTIFICATION

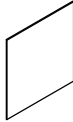
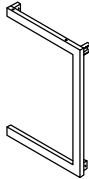
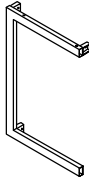
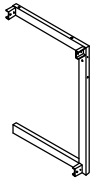
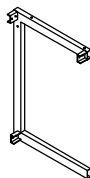

N	SMALL DRAWER BACK PANEL		2PCS
O	SMALL DRAWER BOTTOM PANEL		2PCS
P	LEFT FRONT FRAME		1PC
Q	RIGHT FRONT FRAME		1PC
R	LEFT BACK FRAME		1PC
S	RIGHT BACK FRAME		1PC
T	SHORT CROSSBAR		4PCS

ITEM:881571 ASSEMBLY INSTRUCTIONS



U SUPPORT CROSSBAR  2PCS

V LONG CROSSBAR  1PC

A1 BACK FRAME  1PC















A2 SLIDE RAIL  6PCS

ITEM:881571

ASSEMBLY INSTRUCTIONS

HARDWARE IDENTIFICATION



1	LONG BOLT (ϕ 1/4" x 50mm SR)		9PCS	8	CAM LOCK (ϕ 15mm)		14PCS
2	MEDIUM BOLT (ϕ 1/4" x 38mm SR)		8PCS	9	WOOD DOWEL (8 x 30mm)		14PCS
3	SHORT BOLT (ϕ 1/4" x 13mm SR)		28PCS	10	LEVELER (1/4" x 12mm BLK)		8PCS
4	LONG SCREW (4 x 32mm)		24PCS	11	LARGE CAP (20 x 40mm)		8PCS
5	SLIDE RAIL SCREW (3.5 x 12mm)		18PCS	12	SMALL CAP (20 x 20mm)		2PCS
6	SMALL BOLT (ϕ 5/32" x 12mm)		6PCS	13	GLUE		1PC
7	CAM BOLT (38mm)		14PCS	14	ALLEN WRENCH (4mm)		1PC

ITEM:881571 ASSEMBLY INSTRUCTIONS



STEP 1 Do not tighten until each step is completed or instructed.

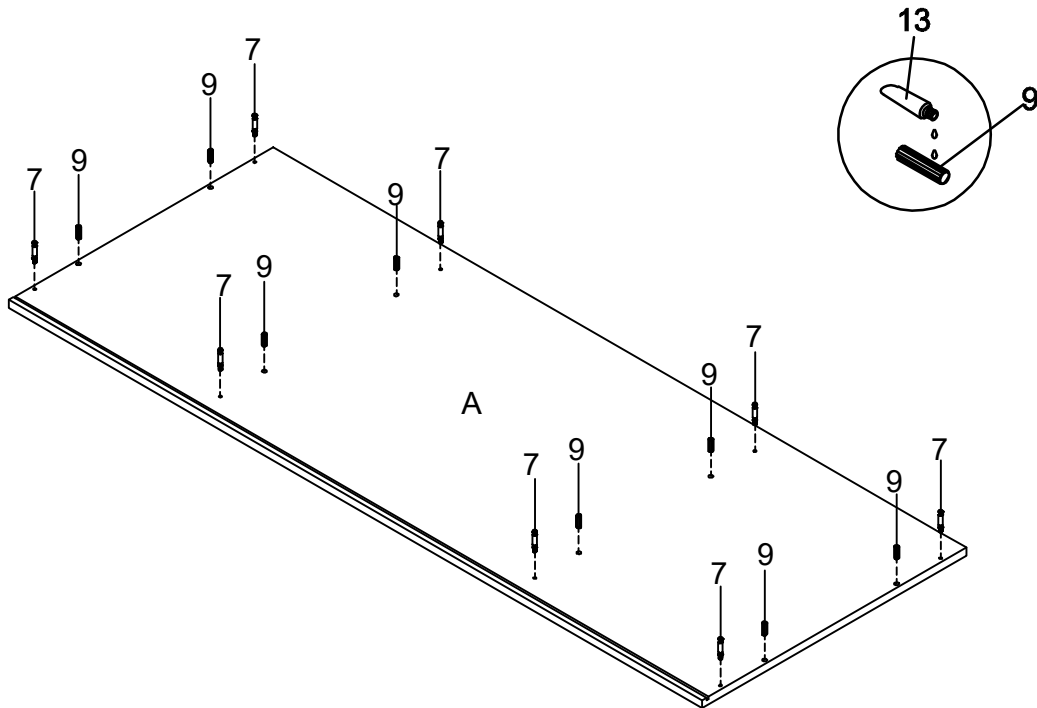

STEP 2

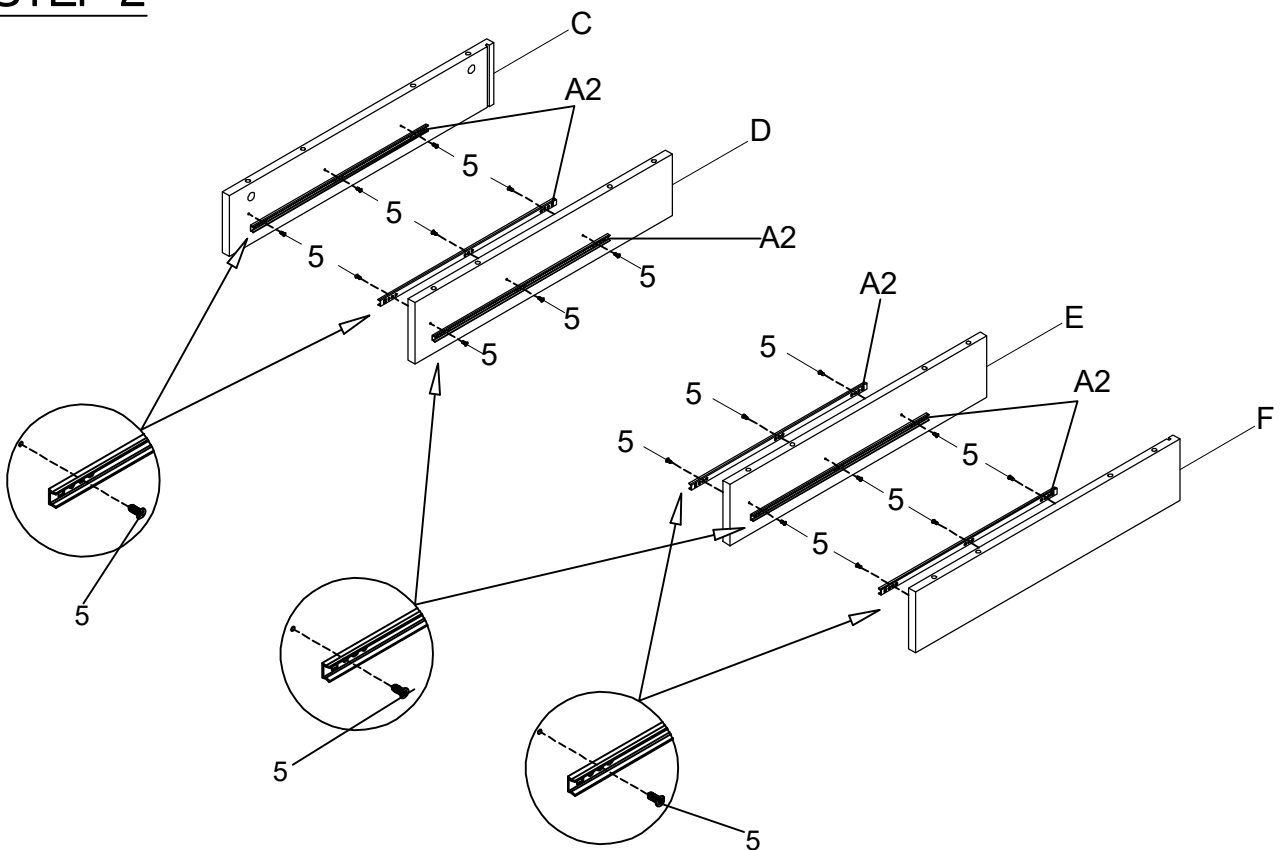

ITEM:881571
ASSEMBLY INSTRUCTIONS
STEP 3

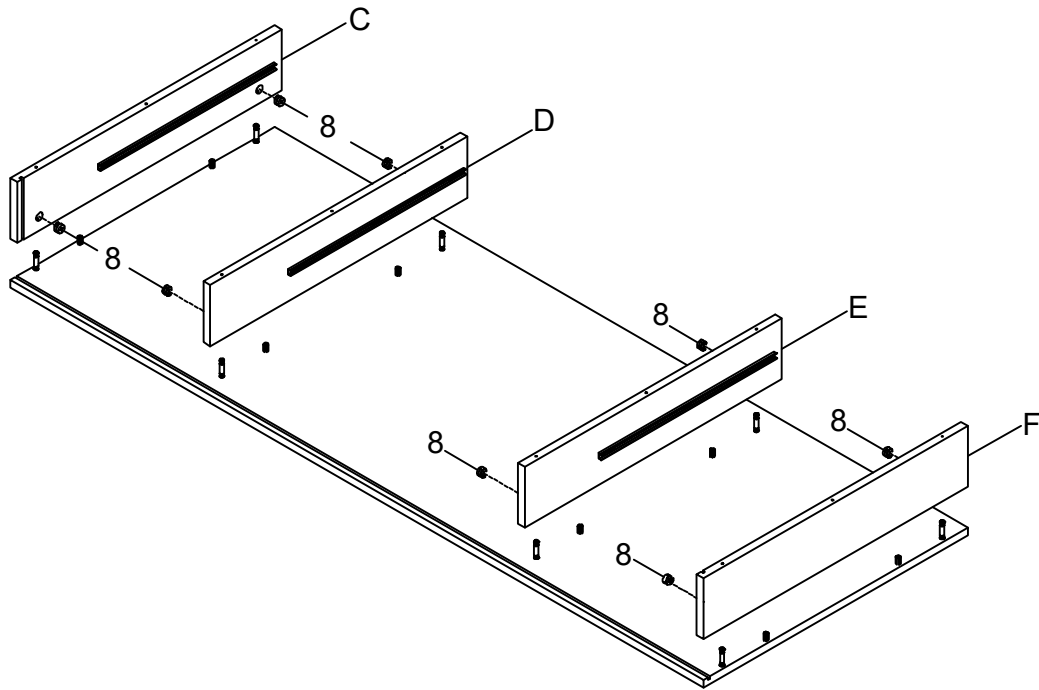

STEP 4

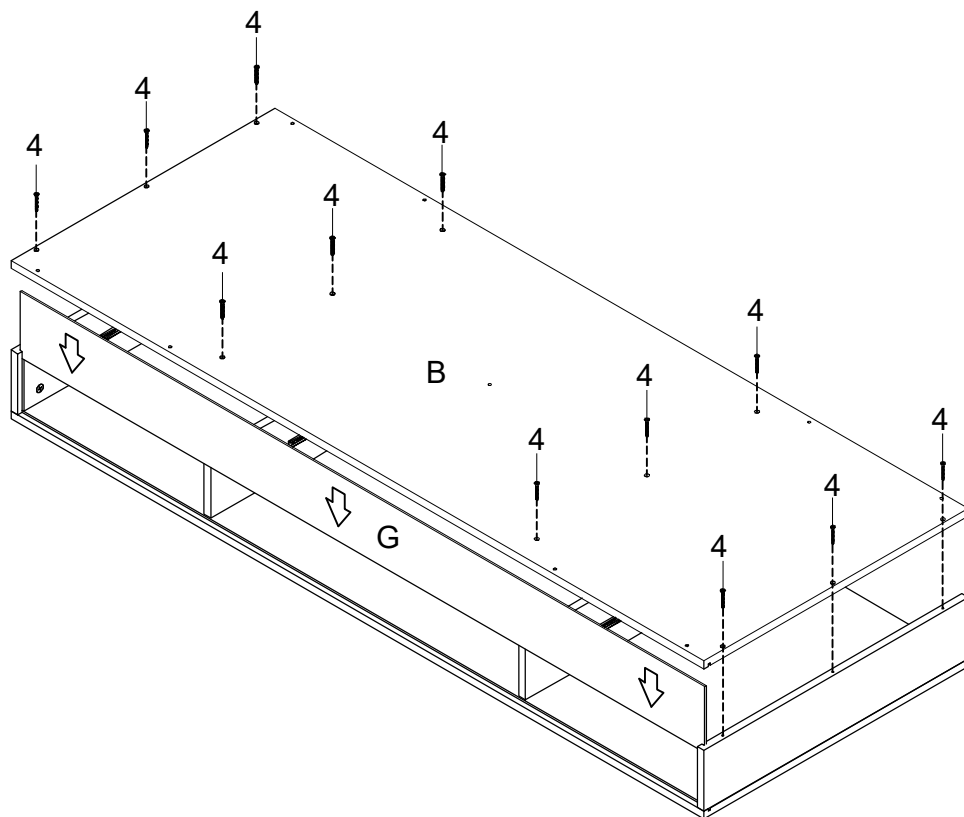

ITEM:881571
ASSEMBLY INSTRUCTIONS
STEP 5

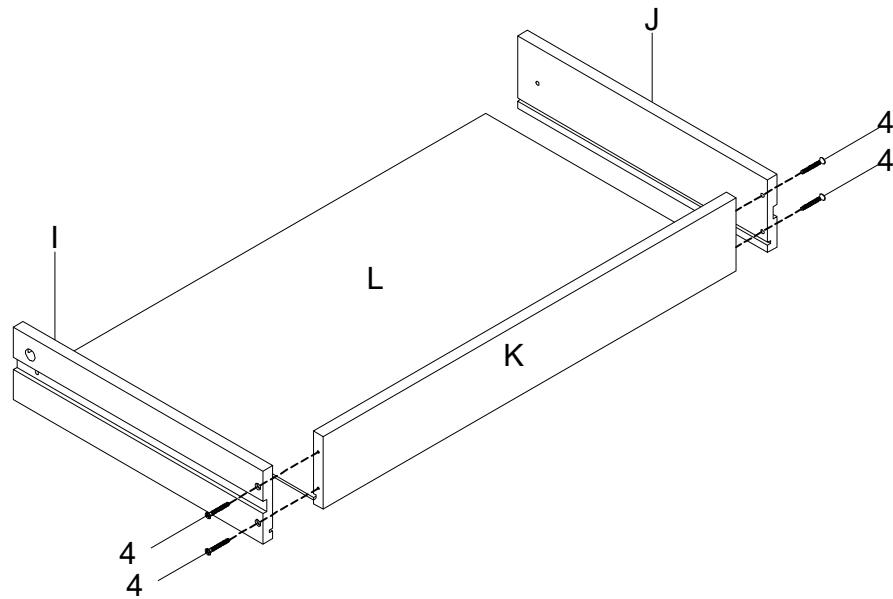

STEP 6

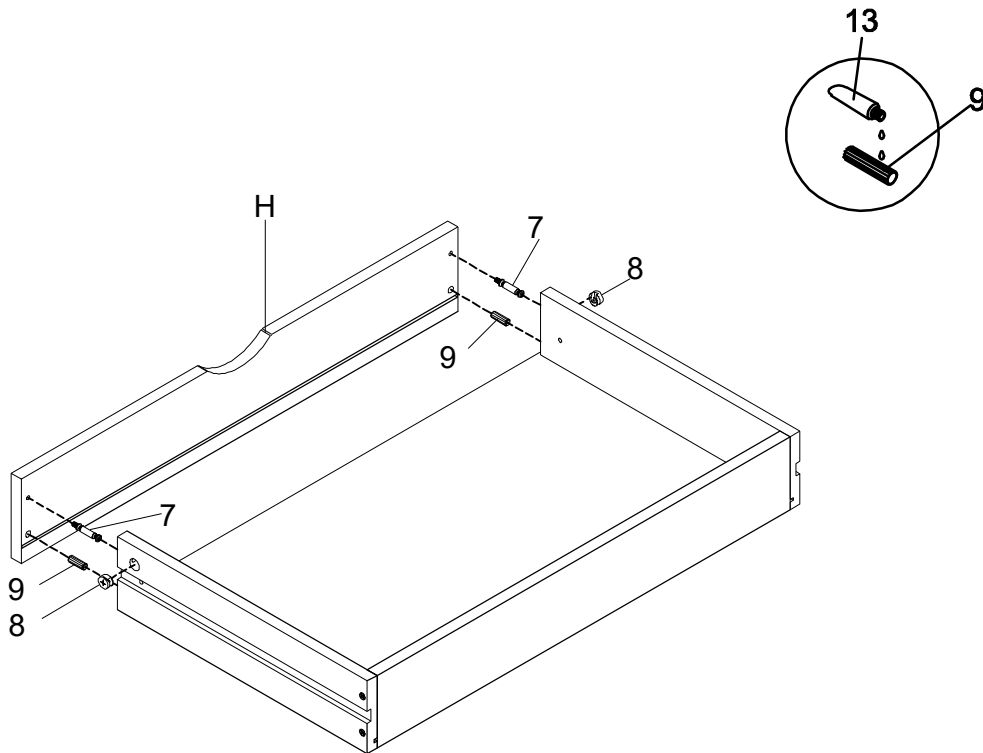

ITEM:881571
ASSEMBLY INSTRUCTIONS
STEP 7

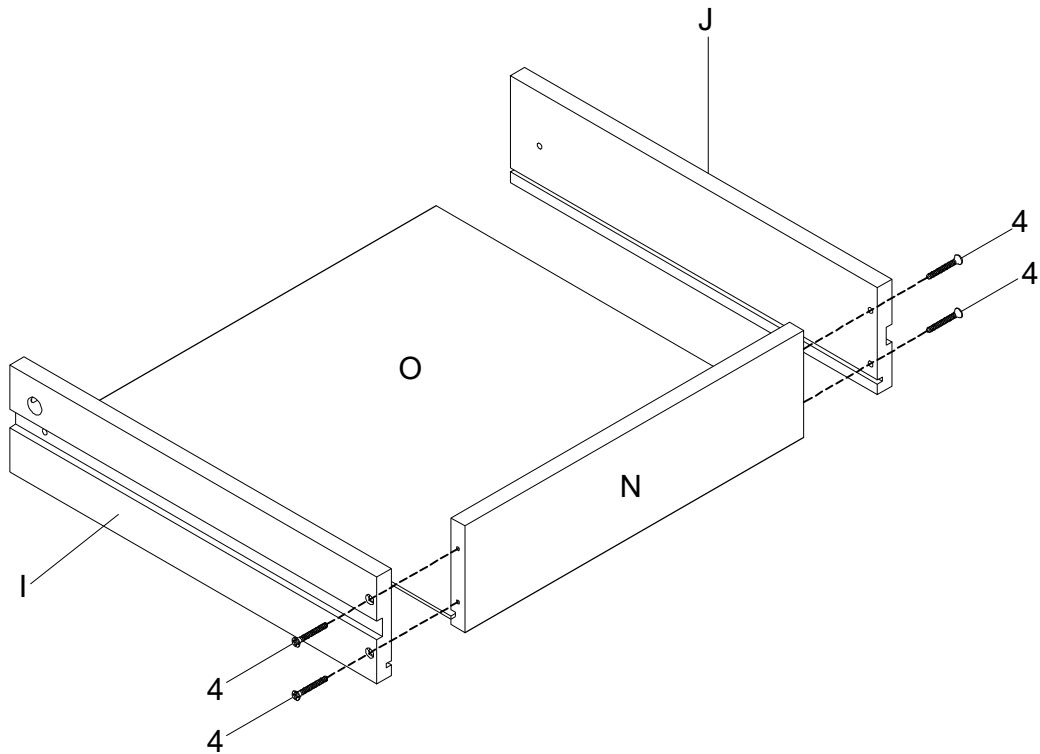

STEP 8

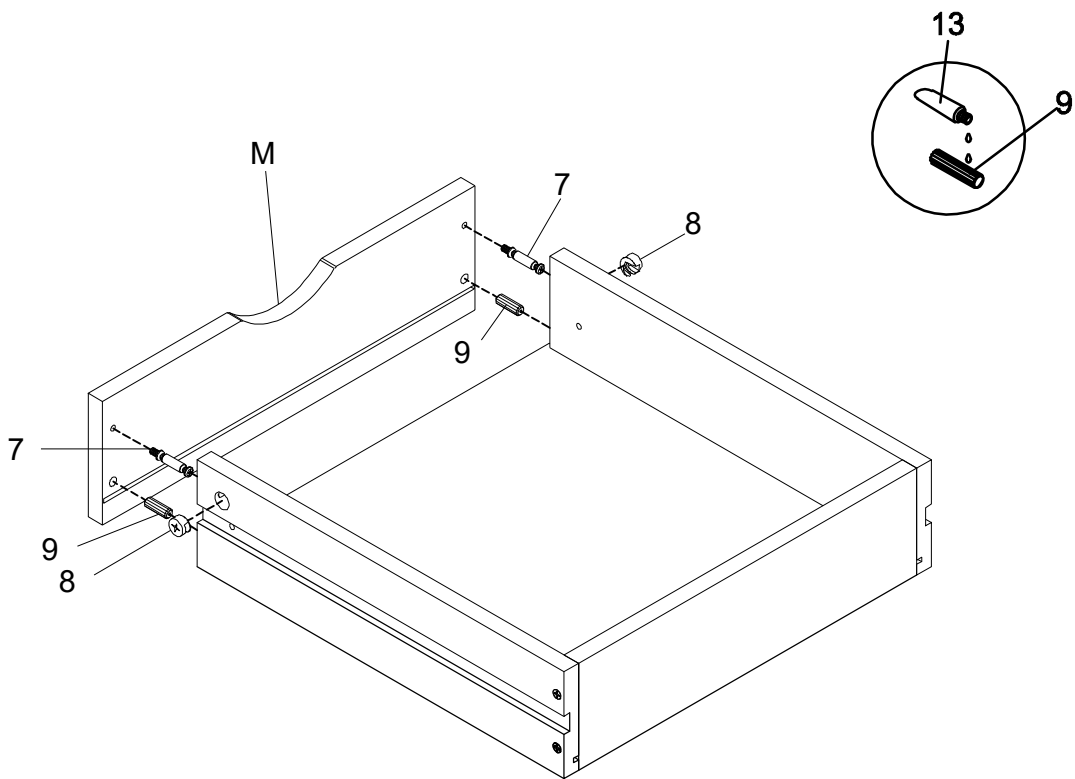

ITEM:881571
ASSEMBLY INSTRUCTIONS
STEP 9

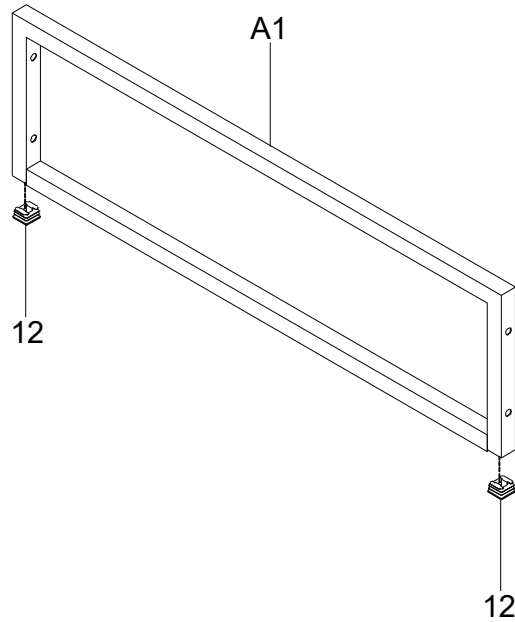

STEP 10

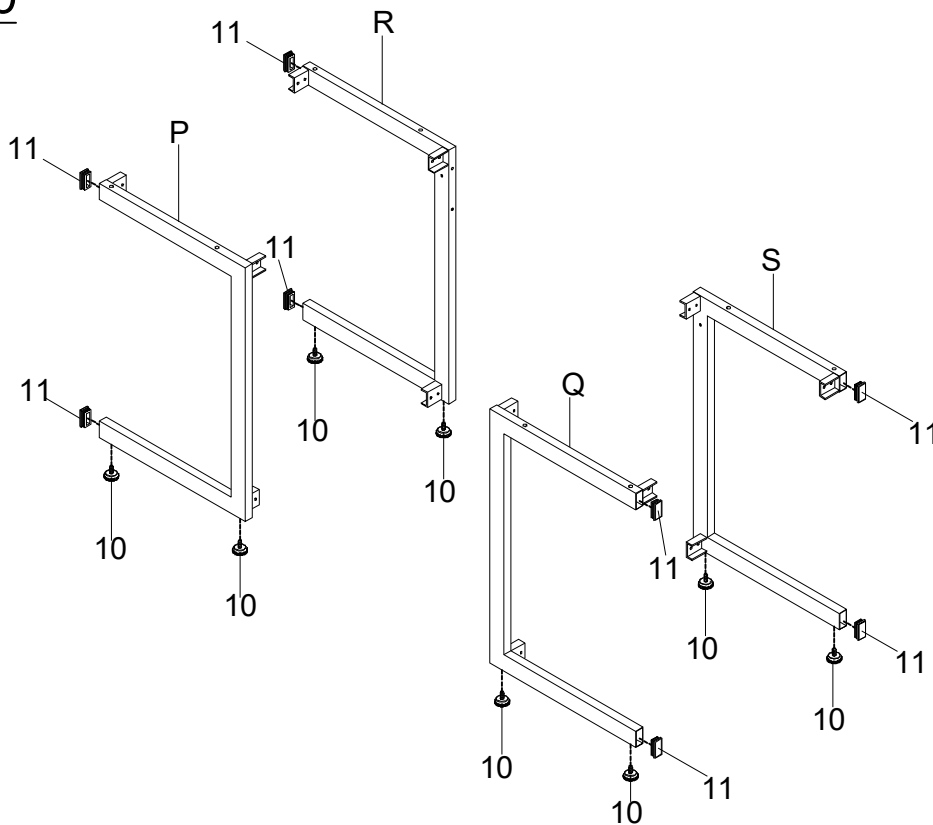

ITEM:881571
ASSEMBLY INSTRUCTIONS
STEP 11

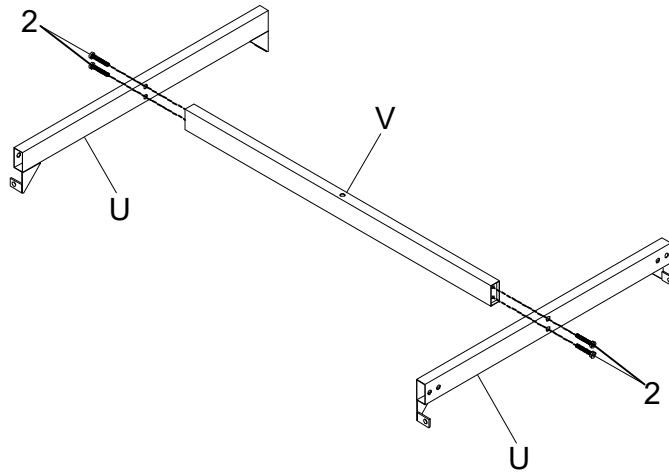

STEP 12

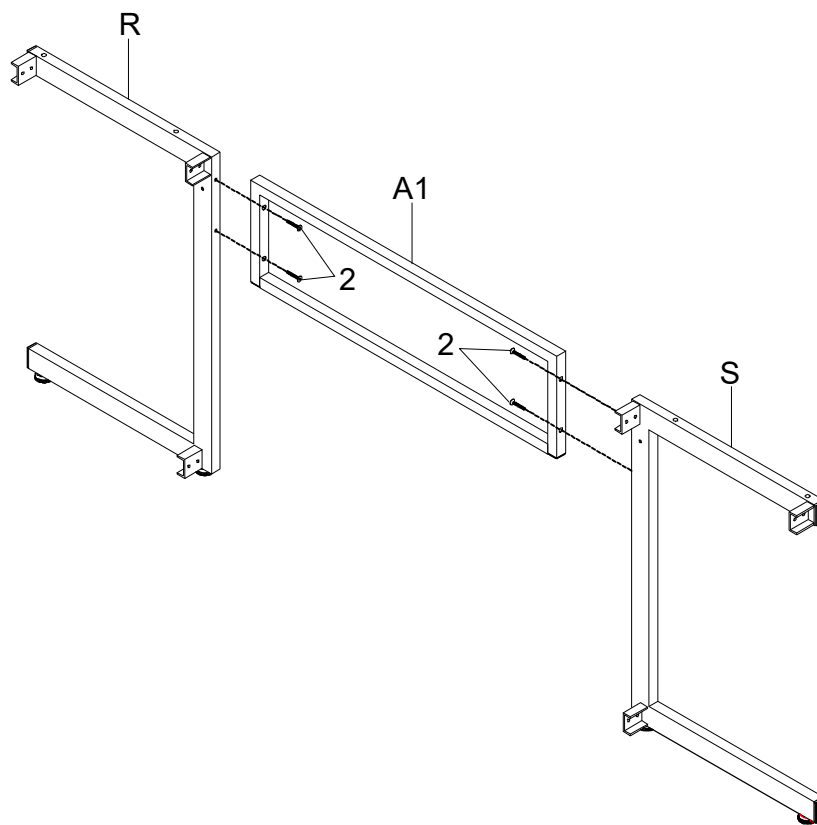

ITEM:881571 ASSEMBLY INSTRUCTIONS



STEP 13

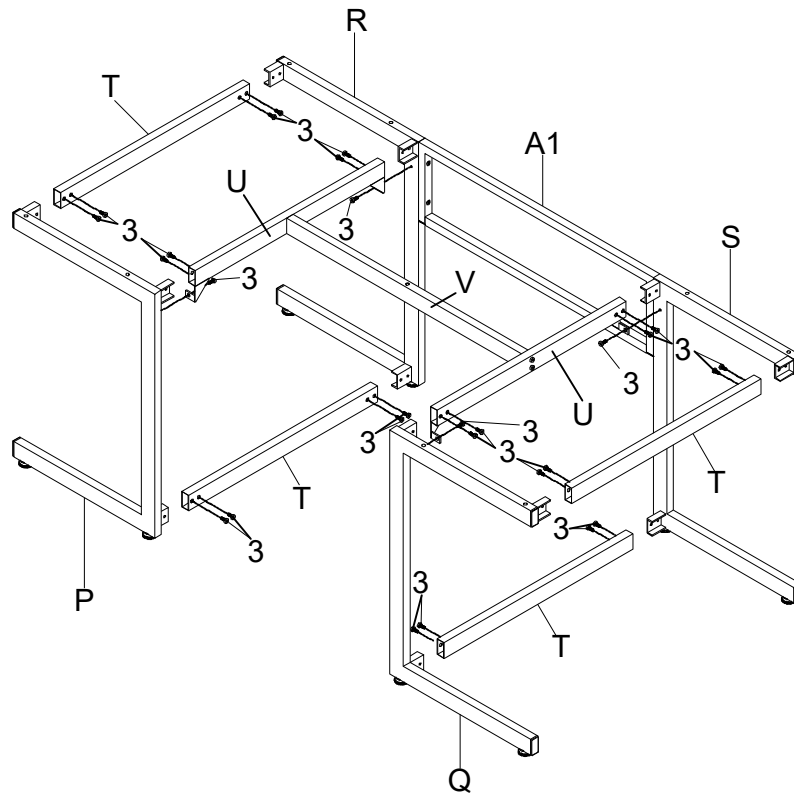

STEP 14

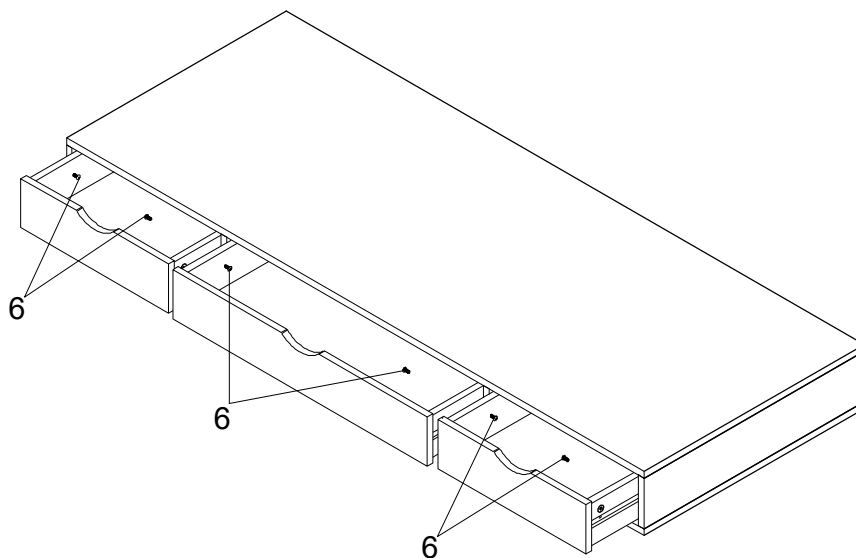

ITEM:881571
ASSEMBLY INSTRUCTIONS
STEP 15

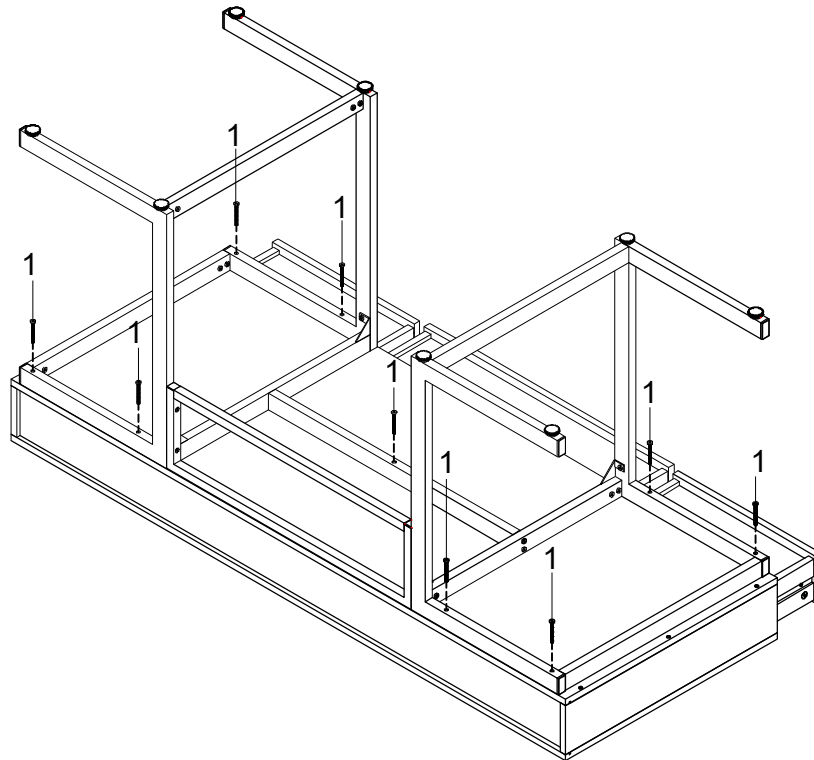

STEP 16
COMPLETE

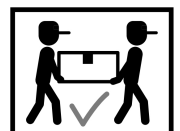
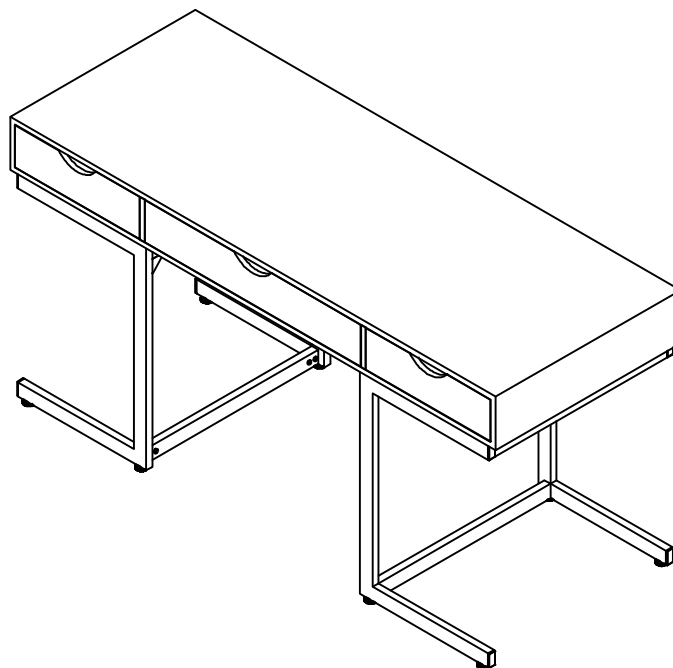

ITEM:881571 ASSEMBLY INSTRUCTIONS



Product Size : 1574 X 597 X 787 H (MM)
Product Size : 62" X 23.5" X 31"

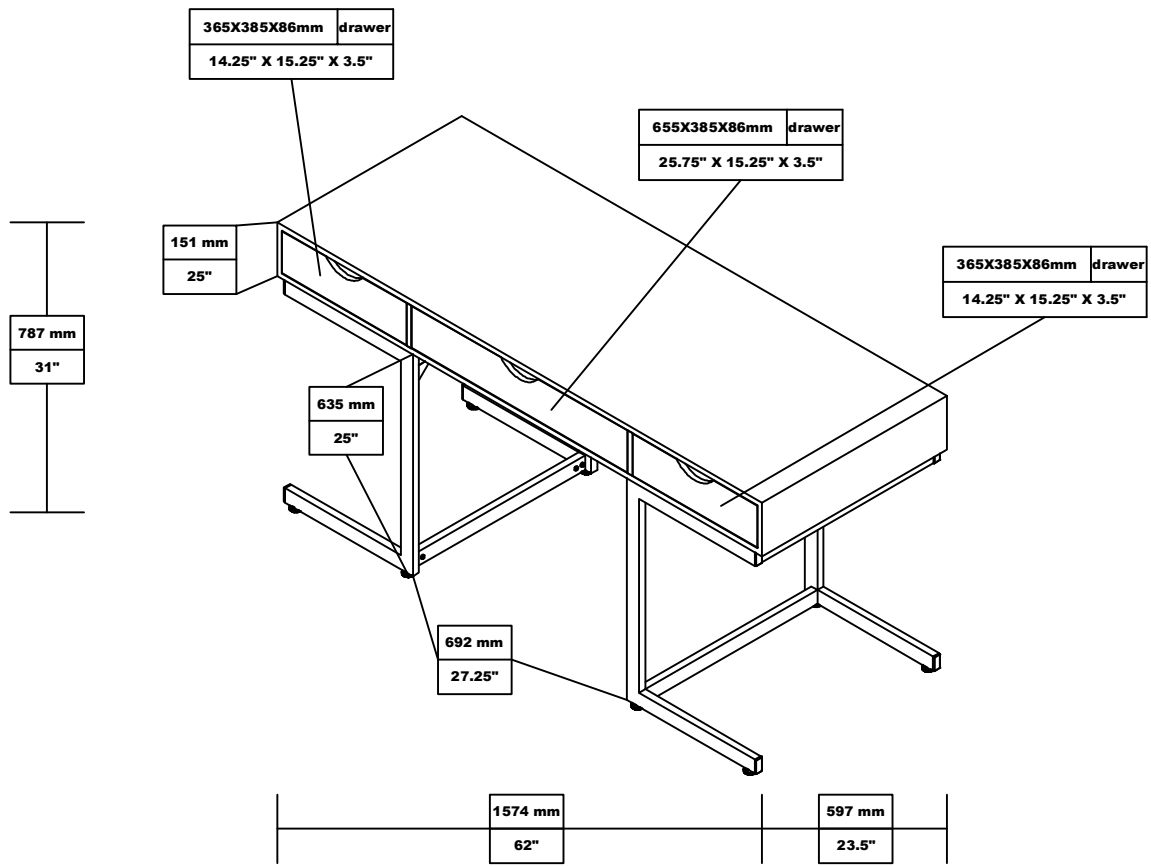

Note : Dimension tolerance $\pm 5\%$