

HDA-I/O OWNER'S MANUAL



TOTAL CONTROL

Introducing the HDA-I/O

The **HDA-I/O Single-Zone Amplifier** is URC's powerful and discrete amplifier! This document highlights product features, LED status conditions, basic installation, and general speaker wiring instructions.

Online Support:

Total Control is sold direct only and must be installed/programmed by a certified custom integrator.

End-User Support:

Visit the [URC Home Page](#) for product information, owner's manuals, and support contact information.

Contact Support:

Total Control is a URC product sold direct only. For questions or assistance contact your Custom Installer/Programmer.

My Installer/Programmer



Technical Support

Toll Free: 800-904-0800

Main: 914-835-4484

techsupport@urc-automation.com

Hours: 9:00am - 5:00pm EST M-F

Table of Contents

Overview	1
Parts & Pieces	2
Front Panel Descriptions	3
Rear Panel Description - Using as a Stream Injector	5
Rear Panel Description - Using as a Stream Receiver	6
Installation Instructions	7
Network Setup	9
HDA Modules	10
Specifications	11
Limited Warranty Statement	11

TOTAL CONTROL

Overview

URC's HDA-I/O Stream Receiver/Injector **creates or receives HDA audio streams over the network**. This device must be configured by a **certified URC integrator** to function as either a **Stream Injector** or **Stream Receiver**.

As a **Stream Injector**, this device distributes **any connected audio source** (digital or analog) over the network to **any available HDA controlled zone**.

As a **Stream Receiver**, the HDA-I/O connects to your favorite **3rd party audio device** and provides it with access to **all HDA audio streams on the network**.

HDA products are **NOT** compatible with URC's legacy Total Control amplifiers (DMS).

Features & Benefits:

- **Stream Receiver or Stream Injector Capabilities:** Configured via URC software, the HDA-I/O can receive or transmit HDA audio streams over the local network.
- **HDA Audio Streams:** As a Stream Injector, this device distributes any connected audio source to any available HDA controlled audio zone.
- **Source Sharing:** Any zone controlled via an HDA amplifier or I/O device has access to the system's HDA Audio Streams.
- **Flexible Zone Linking:** When connected to a 3rd party audio device as a Stream Receiver, the HDA-I/O can link that 3rd party zone with any other HDA controlled zone.
- **Integrated Audio Sensor:** Each available input on the HDA-I/O has built-in audio sensing capabilities. These sensors can be used to trigger programmed events or activities.
- **Zone Input Ducking:** The HDA-I/O has the ability to "fade in" an audio input over the currently selected audio input. The perfect solution to briefly lower the volume on the current source to make an audio announcement or doorbell chime.
- **Power Configuration Options:** The HDA-I/O can be powered via PoE or the supplied 12VDC adapter.



Parts & Pieces

Included with the HDA-I/O are the following:

CONTENTS

- 1 HDA-I/O Stream Adapter**
- 2 12 VDC Adapter**
- 3 US, UK, Euro Plug Adapter**
- 4 Left/Right L Brackets**
- 5 4 L Bracket Screws**
- 6 4 Rubber Feet**

Front Panel Descriptions

There are three (3) LEDs on the front panel of the HDA-I/O:

1. Power LED: Indicates one (1) of the following:

- **Solid Blue:** Power has been applied to the device and it has successfully initialized.
- **Off:** Power has been removed from the device.

2. Status LED: Indicates one (1) of the following:

- **Solid Blue:** The device has been programmed with Total Control software and is ready for operation.
- **Blinking Blue:** The device is receiving a download from the Total Control programming software.
- **Blinking Green:** The device is receiving a firmware upgrade, this light continues to blink until the update is fully applied.
- **Off:** The device has not been programmed with Total Control software.

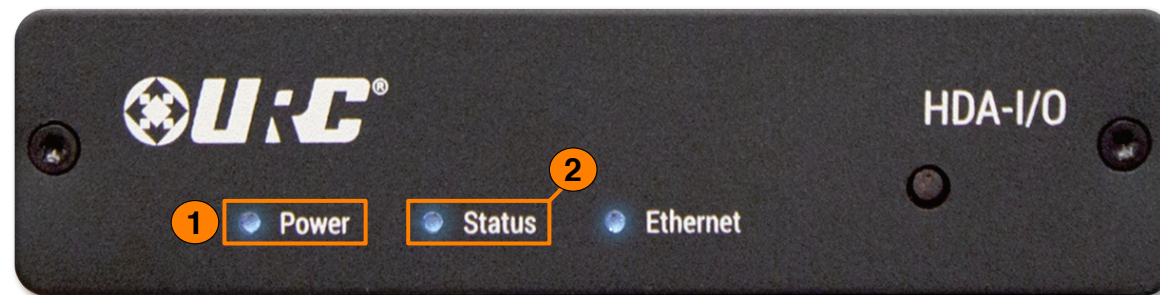

3. Ethernet LED: Indicates one (1) of the following:

- **Solid Blue:** The device has received an IP address from the local network.
- **Blinking Blue:** The device is connected to the local network; however, it has not received an IP address.
- **Off:** The device is not connected to the local network.

4. Reset Button: There are two (2) ways to press this button:

- **Single Press:** Tap the Reset button to power cycle the device.
- **Factory Reset:** Press-n-hold the Reset button for 10 seconds or more.

This option cannot be reversed, once the device has been factory defaulted it **requires re-programming**.

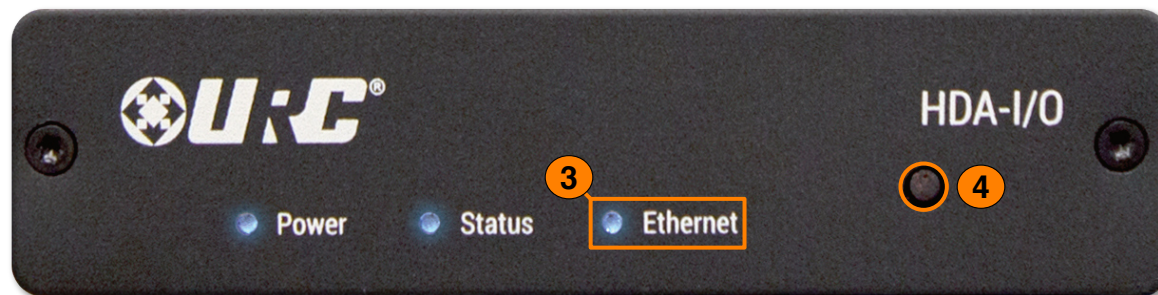

Rear Panel Description - Using as a Stream Injector

Below are the available connections on the rear of the HDA-I/O:

1. **DC IN:** Connect the **supplied 12VDC adapter** to this port to power the HDA-I/O.
2. **LAN:** Full Duplex Gigabit LAN ONLY, for audio streaming and zone control (Wi-Fi NOT supported, device must be hard-lined to the network).
3. **12 VDC CTRL:** Mono 3.5mm connector capable of supplying 150mA of current.
4. **Analog/Digital Inputs:** Both of the following inputs can be used to provide HDA "high-definition" audio streams. Only one input can be in use at any given time.
 - **Analog** - Unbalanced RCA
 - **Toslink** (Optical)
 - **Digital Coax**



TOTAL CONTROL

Rear Panel Description - Using as a Stream Receiver

Below are the available connections on the rear of the HDA-I/O:

1. **DC IN:** Connect the **supplied 12VDC adapter** to this port to power the HDA-I/O.
2. **LAN:** Full Duplex Gigabit LAN ONLY, for audio streaming and zone control (Wi-Fi NOT supported, device must be hard-lined to the network).
3. **12 VDC CTRL:** Mono 3.5mm connector capable of supplying 150mA of current.
4. **Analog/Digital Outputs:** All three (3) available outputs can be used. The HDA-I/O as a stream receiver provides 3rd party audio zones with access to audio sources streaming via HDA.
 - **Analog** - RCA Style
 - **Toslink** (Optical)
 - **Digital Coax**

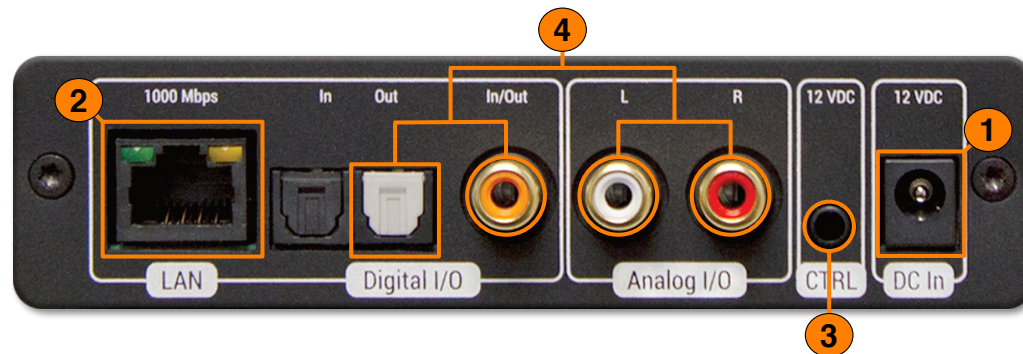

Installation Instructions

The **HDA-I/O amplifier is supplied with two (2) "L" shaped brackets for mounting** on the wall or secure vertical surface.

1. Insert the supplied screws into the two (2) keyed slots on the L shaped bracket (as displayed on the image at the right).

This L shaped bracket **can be pre-installed** and the HDA-I/O amplifier can be inserted afterwards.

2. Insert the supplied screws into the four (4) keyed slots for wall mounting.

Keyhole Diameter: 0.48"/12.5mm

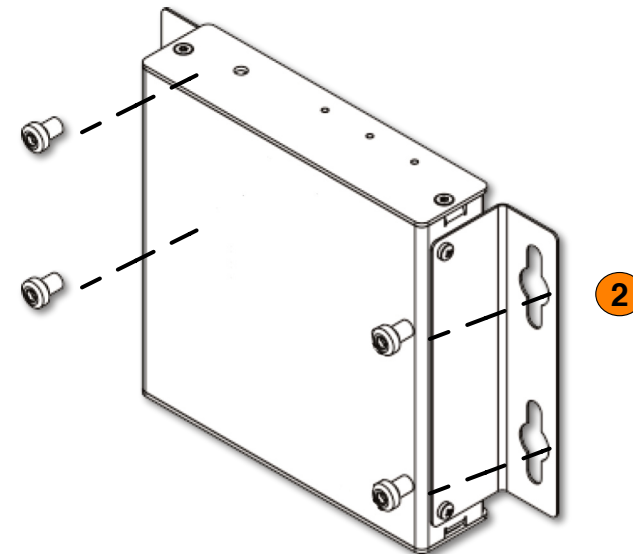
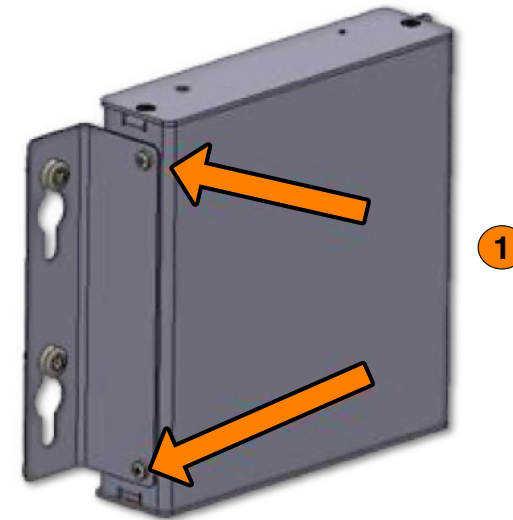

3. Assure that all screws have been installed securely.

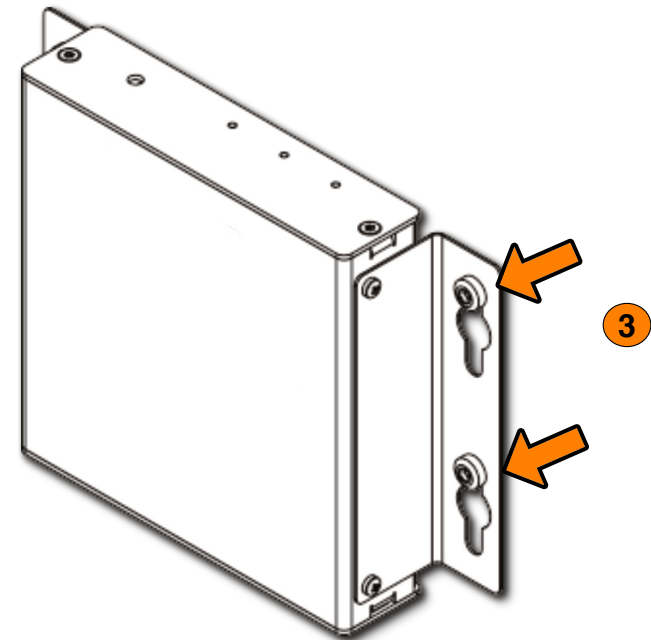

TOTAL CONTROL

Network Setup

When using more than one (1) HDA devices, URC's **HDA-SW5 Network Switch** is **REQUIRED on the local network**.

For more information of the **HDA-SW5 Network Switch**, please refer to the HDA-SW5 Owner's Manual.

Although 3rd Party AVB switches may be utilized, they **are not supported** by URC's Technical Support team.

Connecting the HDA-I/O to the Network

1. Connect an ethernet cable to an available **LAN port** on the head-end network switch.

If no switch is connected to the network then connect the ethernet cable to an available LAN port on the local router (Luxul preferred).
2. Connect the ethernet cable from the previous step to any available LAN port on the **HDA-SW5**.
3. Connect another ethernet cable to an **available LAN port on the HDA-SW5 Network Switch**.
4. Connect the ethernet cable from the previous step to the ethernet port found at the **rear of the HDA-I/O** ([page 5](#)).
5. Configure the HDA-I/O to a **DHCP/MAC reservation** within the local router and program the device into the new or existing Total Control system.

A **certified URC integrator is REQUIRED** to integrate the **HDA-I/O** into a new or existing Total Control system.

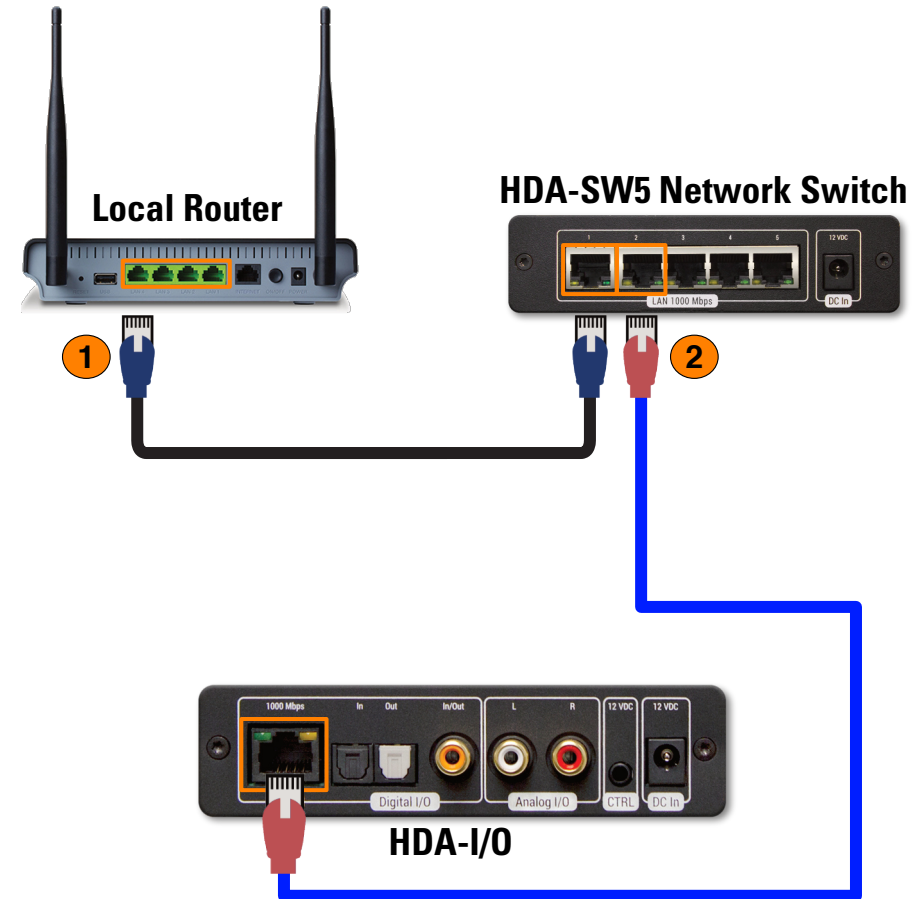

TOTAL CONTROL

HDA Modules

URC's HDA line of products contains several **two-way modules** that are accessible from any graphical user interface.

These modules serve a variety of residential and commercial applications providing end-users with advanced functionality directly from any URC interface.

For specific instructions on how to use these HDA modules, please refer to the **HDA User's Guide**.

The following modules are supported by the **HDA-I/O Multi-Zone Amplifier**:

- Room Volume Module
- Room / Zone EQ Module
- Volume Mixer Module
- Announcement Module
- Input Status
- Amplifier Status
- Zone Status



Not all HDA modules are displayed at the right, for full details on how these modules, refer to the **HDA User's Guide**.



Room / Zone Status



Amplifier Status



Announcements



Room / Zone EQ

TOTAL CONTROL

Specifications

Connections

Audio Inputs:

- 1x Stereo Analog RCA style input
- 1x Toslink (Optical) Digital Input
- 1x Digital Coaxial Input

Audio Outputs:

- 1x Stereo Analog RCA style output
- 1x Toslink (Optical) Digital Input
- 1x Digital Coaxial Input

Dimensions

- 1.44" x 4.94" x 5"

Weight

- 0.65 lbs

Audio

- 96 kHz / 24-bit streaming
- Dolby Digital® and DTS® 5.1 channel Downmixing (digital inputs only)
- Ducking input capability
- Page event support
- Store up to 10 .WAV files in each amplifier (for doorbell ring and/or trigger alert chimes)

Thermal

- Operating Temperature: 32°F to 86°F
- Humidity: Maximum 95%
- Storage: -40°F to 140°F

Power

- Power Consumption: 12V DC 0.9A (supplied adapter)

Limited Warranty Statement

<https://www.urc-automation.com/legal/warranty-statement/>

End User Agreement

The terms and conditions of the End User Agreement available at <https://www.urc-automation.com/legal/end-user-agreement/> shall apply.

Federal Communication Commission Interference Statement

This equipment has been tested and found to comply with the limits for a Class B digital device, pursuant to part 15 of the FCC Rules. These limits are designed to provide reasonable protection against harmful interference in a residential installation. This equipment generates, uses and can radiate radio frequency energy and, if not installed and used in accordance with the instructions, may cause harmful interference to radio communications. However, there is no guarantee that interference will not occur in a particular installation. If this equipment does cause harmful interference to radio or television reception, which can be determined by turning the equipment off and on, the user is encouraged to try to correct the interference by one more of the following measures:

- Reorient or relocate the receiving antenna.
- Increase the separation between the equipment and receiver.
- Connect the equipment into an outlet on a circuit different from that to which the receiver is connected.
- Consult the dealer or an experienced radio/TV technician for help.

TOTAL CONTROL

CERTIFICATE OF COMPLIANCE

Certificate Number	E496941
Report Reference	E496941-A6019-UL
Issue Date	2020-JUNE-29

Issued to: ICEPOWER A/S
Vandtarnsvej 62A, 3B
2860 Soborg DENMARK

This certificate confirms that representative samples of Audio/Video, Information and Communication Technology Equipment
Network switch and Network I/O
Model: HDA-SW5, HDA-I/O

Have been investigated by UL in accordance with the Standard(s) indicated on this Certificate.

Standard(s) for Safety: UL 62368-1 and CAN/CSA C22.2 No. 62368-1-14
Audio/video, information and communication technology equipment Part 1: Safety requirements

Additional Information: See the UL Online Certifications Directory at <https://iq.ulprospector.com> for additional information.

This Certificate of Compliance does not provide authorization to apply the UL Mark. Only the UL Follow-Up Services Procedure provides authorization to apply the UL Mark.

Only those products bearing the UL Mark should be considered as being UL Certified and covered under UL's Follow-Up Services.

Look for the UL Certification Mark on the product.

Bruce Maheshwari, Director North American Certification Program
UL LLC



Any information and documentation involving UL Mark services are provided on behalf of UL LLC (UL) or any authorized licensee of UL. For questions, please contact a local UL Customer Service Representative at <http://ul.com/customer-service>

Warning!

The manufacturer is not responsible for any Radio or TV interference caused by unauthorized modifications to this equipment.

Changes or modifications not expressly approved by the manufacturer could void the user's authority to operate the equipment.

Regulatory Information to the User

- CE conformity Notice Products with "CE" marking comply EMC Directive 2014/30/EU issued by the commission of the European Community.
 1. EMC Directive
 - Emission
 - Immunity
 - Power
- Declaration of Conformity

"Hereby, Universal Remote Control Inc. declares that this HDA-I/O is in compliance with the Essential requirements."