

INSTALLATION INSTRUCTIONS

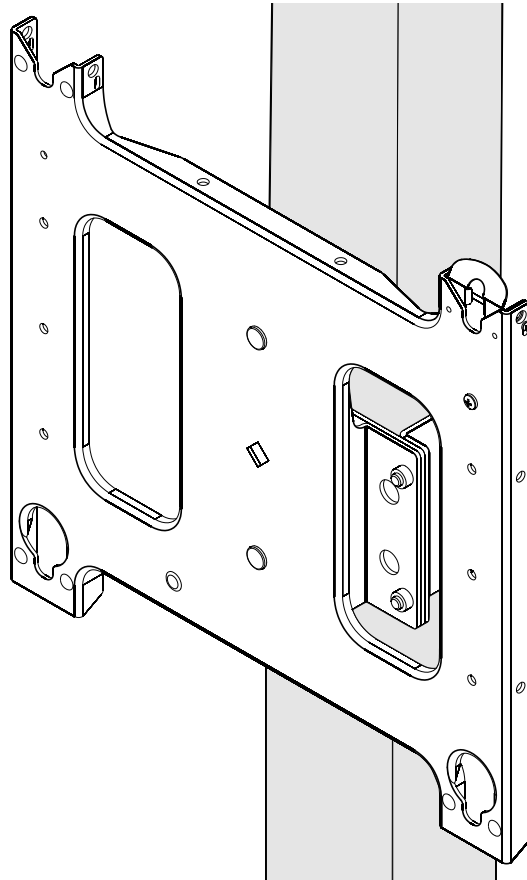



Cart and Stand Clamp Head Accessory

DISCLAIMER

CSAV, Inc., and its affiliated corporations and subsidiaries (collectively, "CSAV"), intend to make this manual accurate and complete. However, CSAV makes no claim that the information contained herein covers all details, conditions or variations, nor does it provide for every possible contingency in connection with the installation or use of this product. The information contained in this document is subject to change without notice or obligation of any kind. CSAV makes no representation of warranty, expressed or implied, regarding the information contained herein. CSAV assumes no responsibility for accuracy, completeness or sufficiency of the information contained in this document.

IMPORTANT WARNINGS AND CAUTIONS!

 **WARNING:** A WARNING alerts you to the possibility of serious injury or death if you do not follow the instructions.

 **CAUTION:** A CAUTION alerts you to the possibility of damage or destruction of equipment if you do not follow the corresponding instructions.

 **WARNING:** Failure to read, thoroughly understand, and follow all instructions can result in serious personal injury, damage to equipment, or voiding of factory warranty! It is the installer's responsibility to make sure all components are properly assembled and installed using the instructions provided.

 **WARNING:** Exceeding the weight capacity can result in serious personal injury or damage to equipment! It is the installer's responsibility to make sure the combined weight of all components on the cart/stand does not exceed 200 lbs (90.72 kg) for the PFC, 200 lbs (90.72 kg) for the PF1, 400 lbs (181.44 kg) for the PF2 [200 lbs (90.72 kg) per faceplate].

LEGEND

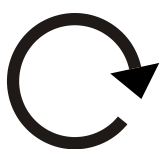
	Tighten Fastener
	Apretar elemento de fijación
	Befestigungsteil festziehen
	Apertar fixador
	Serrare il fissaggio
	Bevestiging vastdraaien
	Serrez les fixations
	Сожмите Застежку

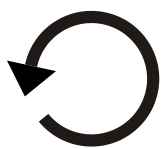
	Loosen Fastener
	Aflojar elemento de fijación
	Befestigungsteil lösen
	Desapertar fixador
	Allentare il fissaggio
	Bevestiging losdraaien
	Desserrez les fixations
	Ослабьте Застежку

	Hex-Head Wrench
	Llave de cabeza hexagonal
	Sechskantschlüssel
	Chave de cabeça sextavada
	Chiave esagonale
	Zeskantsleutel
	Clé à tête hexagonale
	Главный ведемой Рывок

	Phillips Screwdriver
	Destornillador Phillips
	Kreuzschlitzschraubendreher
	Chave de fendas Phillips
	Cacciavite a stella
	Kruiskopschroevendraaier
	Tournevis à pointe cruciforme
	Отвертка

TOOLS REQUIRED FOR INSTALLATION AND PARTS

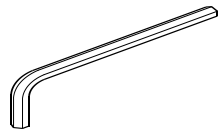
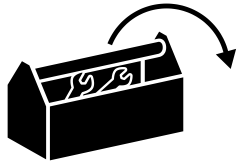

3/16"
(Provided)

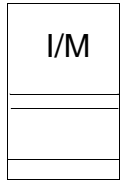

I/M

x1

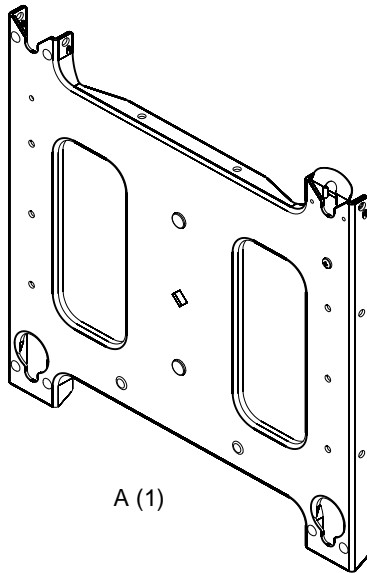

A (1)

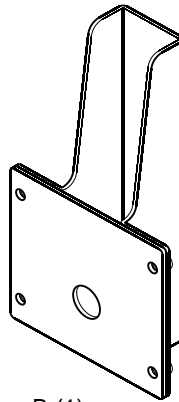

B (1)

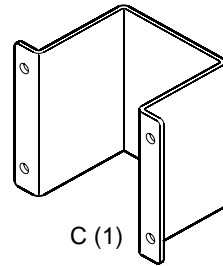

C (1)



D (4)
(5/16-18 x 3/4")



E (2)
(3/8-16)

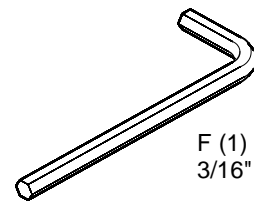

F (1)
3/16"

ASSEMBLY AND INSTALLATION



WARNING: EXCEEDING MAXIMUM WEIGHT CAPACITY MAY LEAD TO SERIOUS PERSONAL INJURY OR DAMAGE TO EQUIPMENT! It is the installer's responsibility to ensure the total amount of weight placed on the cart/stand does not exceed 200 lbs (90.72 kg) for the PFC, 200 lbs (90.72 kg) for the PF1, 400 lbs (181.44 kg) for the PF2 [200 lbs (90.72 kg) per faceplate].

Installing Display(s) to Cart/Stand

1. Install display(s) to cart or stand following the installation instructions included with the cart/stand.

Assembling Faceplate to Bracket

1. Attach faceplate (A) to bracket (B) using two 3/8-16 Nylock lock nuts (E). (See Figure 1)

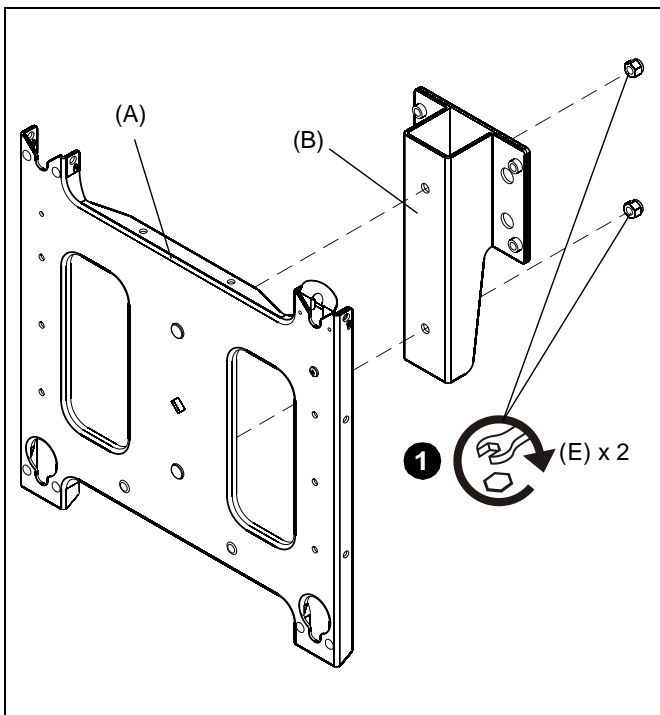

Figure 1

2. Secure faceplate with bracket around post to clamp bracket (C) using four 5/16-18 x 3/4" buttonhead cap screws (D).

NOTE: The faceplate assembly must be attached to the clamp bracket **below the knob** on the lower part of the cart/stand post.

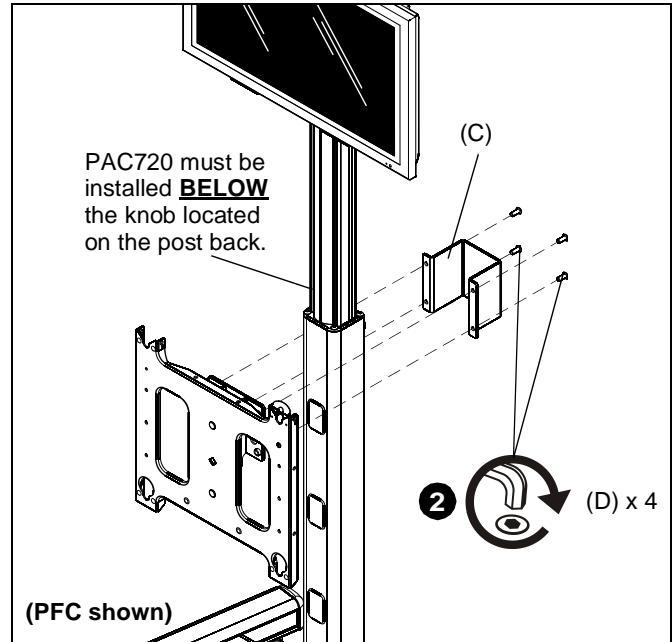

Figure 2

Assembly for Dual Display



WARNING: TIPPING HAZARD! Place PAC720 only on **FRONT** of PFC and PF1. PAC720 may be placed on **both FRONT and BACK** of PF2.

1. Attach first faceplate (A) to bracket (B) using two 3/8-16 Nylock lock nuts (E). (See Figure 1)
2. Attach second faceplate (A) to bracket (B) using two 3/8-16 Nylock lock nuts (E). (See Figure 3)

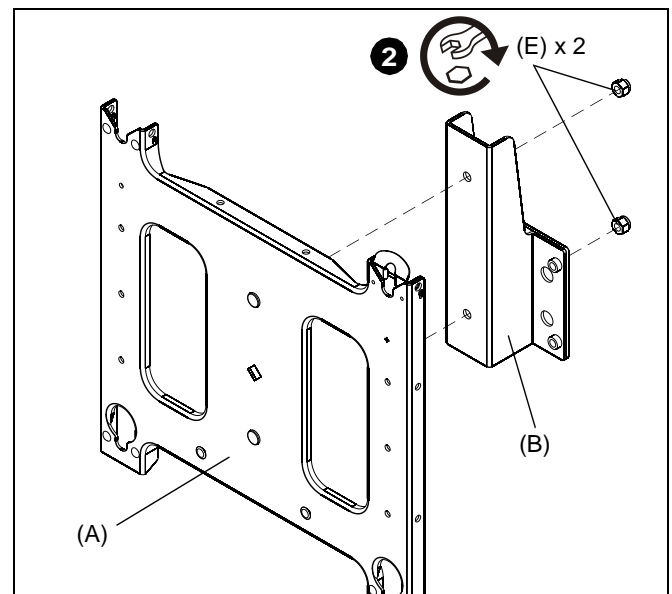

Figure 3

3. Secure faceplate assemblies with bracket to clamp brackets (C) onto cart/stand post using four 5/16-18 x 3/4" buttonhead cap screws (D) on **EACH** assembly. (See Figure 4)

NOTE: The faceplate assembly must be attached to the clamp bracket **below the knob** on the lower part of the cart/stand post.

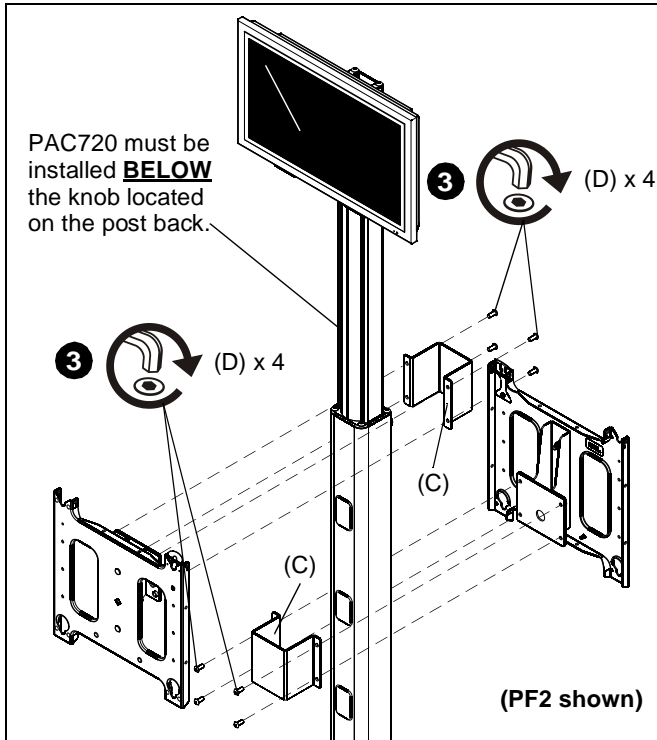

Figure 4

Attaching Display

1. While supporting both sides of display, align four mounting buttons on display or interface bracket with four mounting holes in faceplate. (See Figures 5 and 6)

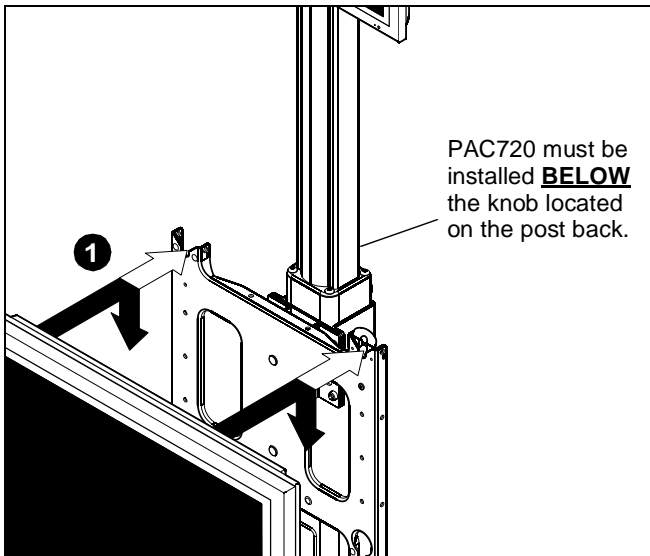

Figure 5

40 LBS! Always use two people and proper lifting techniques when installing or positioning display on stand.

2. Lower display into place listening for audible "click" to ensure recessed area of mounting buttons are properly seated in lower area of mounting holes. (See Figures 5 and 6)

WARNING: IMPROPER INSTALLATION CAN LEAD TO CART/STAND OR DISPLAY FALLING CAUSING SERIOUS PERSONAL INJURY OR DAMAGE TO EQUIPMENT! Ensure mounting buttons are completely engaged in mounting holes.

NOTE: Holes are provided in the faceplate for use with a padlock or similar locking device, if desired. In addition, the pin and nut may be removed from the upper holes and moved to the lower holes for use as a more permanent locking device. (See Figure 6)

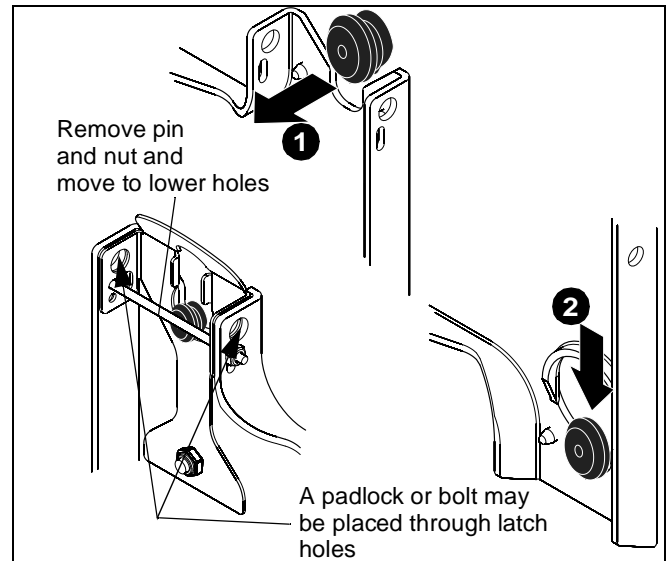

Figure 6

3. To adjust location of display on cart/stand, support display(s) and carefully loosen four 5/16-18 x 3/4" buttonhead cap screws (D) on each faceplate assembly.
4. Slide display(s) up on post to desired position and tighten four 5/16-18 x 3/4" buttonhead cap screws (D) for each faceplate assembly. (See Figures 2 and 4)
5. Refer to the installation instructions provided with the cart/stand for further information on **Tilting Display, Removing Display, Cable Management** and **Cart/Stand Maintenance**.

WARNING: EACH DISPLAY MAY WEIGH IN EXCESS OF



8832-000231
©2007 Chief Manufacturing
www.chiefmfg.com
07/07

USA/International	A 8401 Eagle Creek Parkway, Savage, MN 55378 P 800.582.6480 / 952.894.6280 F 877.894.6918 / 952.894.6918
Europe	A Fellenoord 130 5611 ZB EINDHOVEN, The Netherlands P +31 40 2668620 F +31 (0) 40 2668615
Asia Pacific	A Room 30I, Block D, Lily YinDu International Building LuoGang, BuJi Town, Shenzhen, CHINA. Post Code: 518112 深圳市布吉罗岗百合银都国际大厦D栋30I P +86-755-8996 9226 ; 8996 9236 ; 8996 9220 F +86-755-8996 9217