

INSTALLATION INSTRUCTIONS

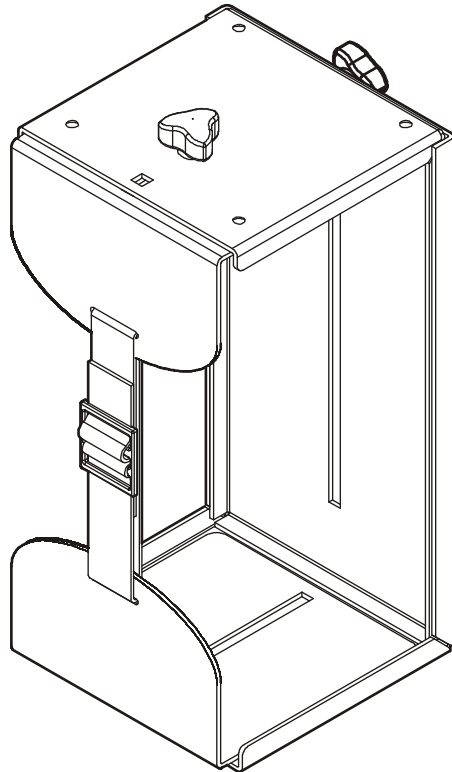

Wall and Desk CPU Mount

DISCLAIMER

Milestone AV Technologies, and its affiliated corporations and subsidiaries, (collectively, Milestone) intend to make this manual accurate and complete. However, Milestone makes no claim that the information contained herein covers all details, conditions or variations, nor does it provide for every possible contingency in connection with the installation or use of this product. The information contained in this document is subject to change without notice or obligation of any kind. Milestone makes no representation of warranty, expressed or implied, regarding the information contained herein. Milestone assumes no responsibility for accuracy, completeness or sufficiency of the information contained in this document.

Chief® is a registered trademark of Milestone AV Technologies. All rights reserved.



IMPORTANT WARNINGS AND CAUTIONS!



WARNING: A WARNING alerts you to the possibility of serious injury or death if you do not follow the instructions.



CAUTION: A CAUTION alerts you to the possibility of damage or destruction of equipment if you do not follow the corresponding instructions.



WARNING: Failure to read, thoroughly understand, and follow all instructions can result in serious personal injury, damage to equipment, or voiding of factory warranty! It is the installer's responsibility to make sure all components are properly assembled and installed using the instructions provided.



WARNING: Failure to provide adequate structural strength for this component can result in serious personal injury or damage to equipment! It is the installer's responsibility to make sure the structure to which this component is attached can support five times the combined weight of all equipment. Reinforce the structure as required before installing the component. The wall to which the mount is being attached may have a maximum drywall thickness of 5/8" (1.6cm) [1/2" minimum for steel stud installation]. Do not install drywall anchors into the seam between drywall pieces.



WARNING: Exceeding the weight capacity can result in serious personal injury or damage to equipment! It is the installer's responsibility to make sure the combined weight of all components attached to this accessory does not exceed 40 lbs (18.1 kg).



WARNING: Use this mounting system only for its intended use as described in these instructions. Do not use attachments not recommended by the manufacturer.



WARNING: Never operate this mounting system if it is damaged. Return the mounting system to a service center for examination and repair.



WARNING: Do not use this product outdoors.

IMPORTANT ! : The KSA1020 mount is designed to be mounted to a 2" x 4" wood studs (16" on center) wall, a 2" x 4"-25ga minimum steel studs wall, drywall, or a desk top.

--SAVE THESE INSTRUCTIONS--

DIMENSIONS

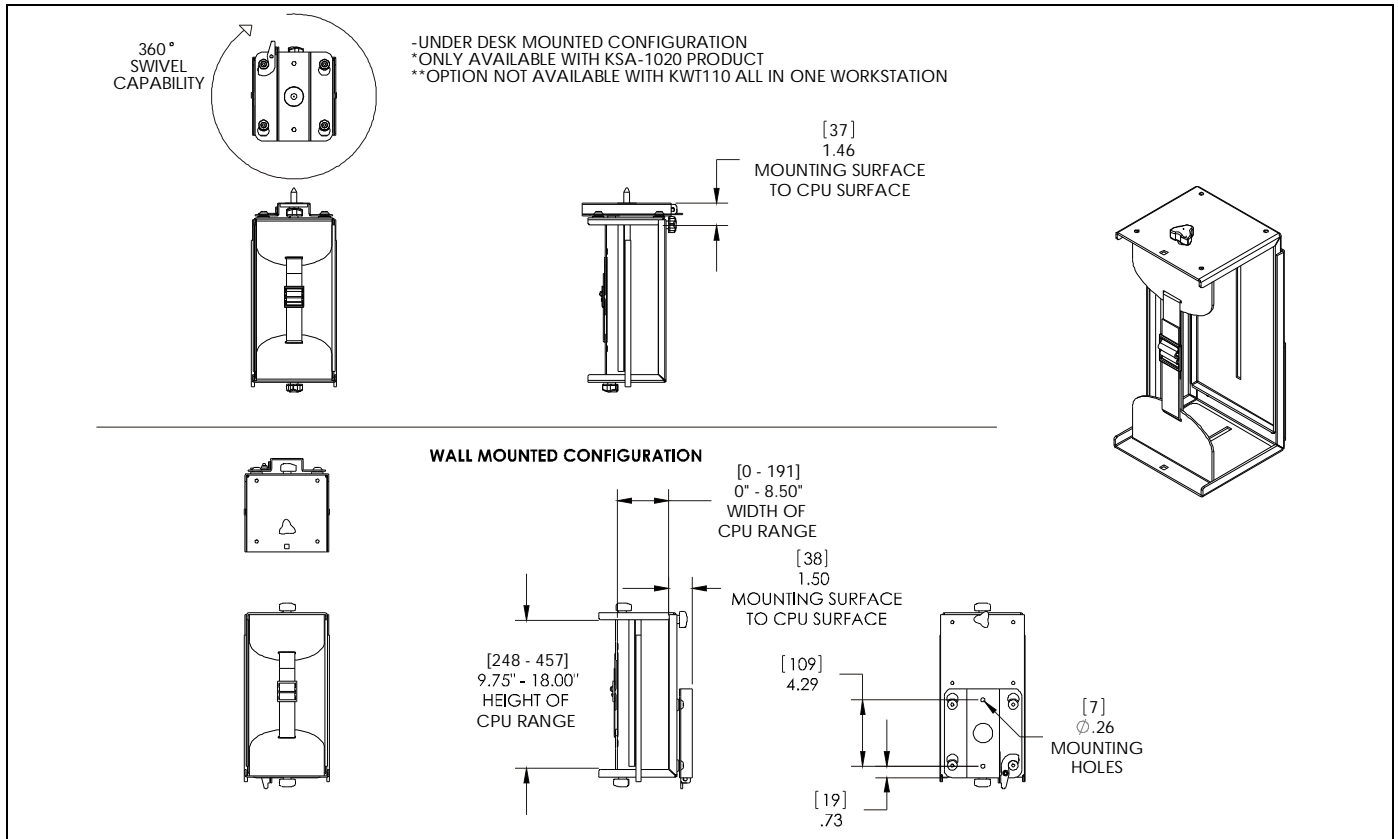

LEGEND

	Tighten Fastener		Pencil Mark
	Apretar elemento de fijación		Marcar con lápiz
	Befestigungsteil festziehen		Stiftmarkierung
	Apertar fixador		Marcar com lápis
	Serrare il fissaggio		Segno a matita
	Bevestiging vastdraaien		Potloodmerkten
Serrez les fixations	Marquage au crayon		
	Loosen Fastener		Drill Hole
	Aflojar elemento de fijación		Perforar
	Befestigungsteil lösen		Bohrloch
	Desapertar fixador		Fazer furo
	Allentare il fissaggio		Praticare un foro
	Bevestiging losdraaien		Gat boren
Desserrez les fixations	Percez un trou		
	Phillips Screwdriver		Open-Ended Wrench
	Destornillador Phillips		Llave de boca
	Kreuzschlitzschraubendreher		Gabelschlüssel
	Chave de fendas Phillips		Chave de bocas
	Cacciavite a stella		Chiave a punte aperte
	Kruiskopschroevendraaier		Steeksleutel
Tournevis à pointe cruciforme	Clé à fourche		

TOOLS REQUIRED FOR INSTALLATION

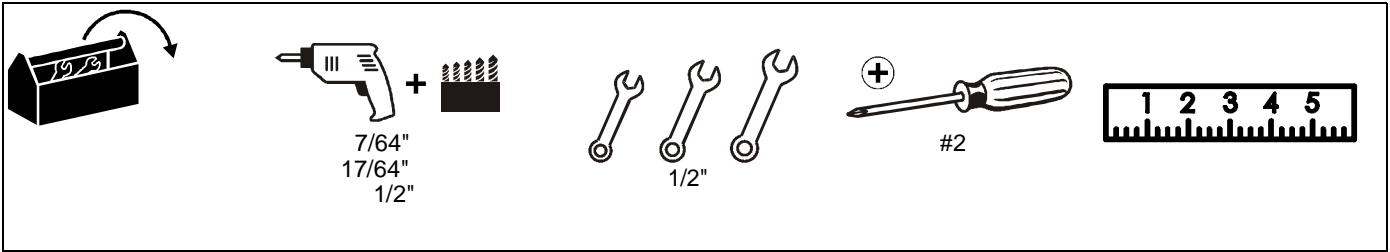

PARTS

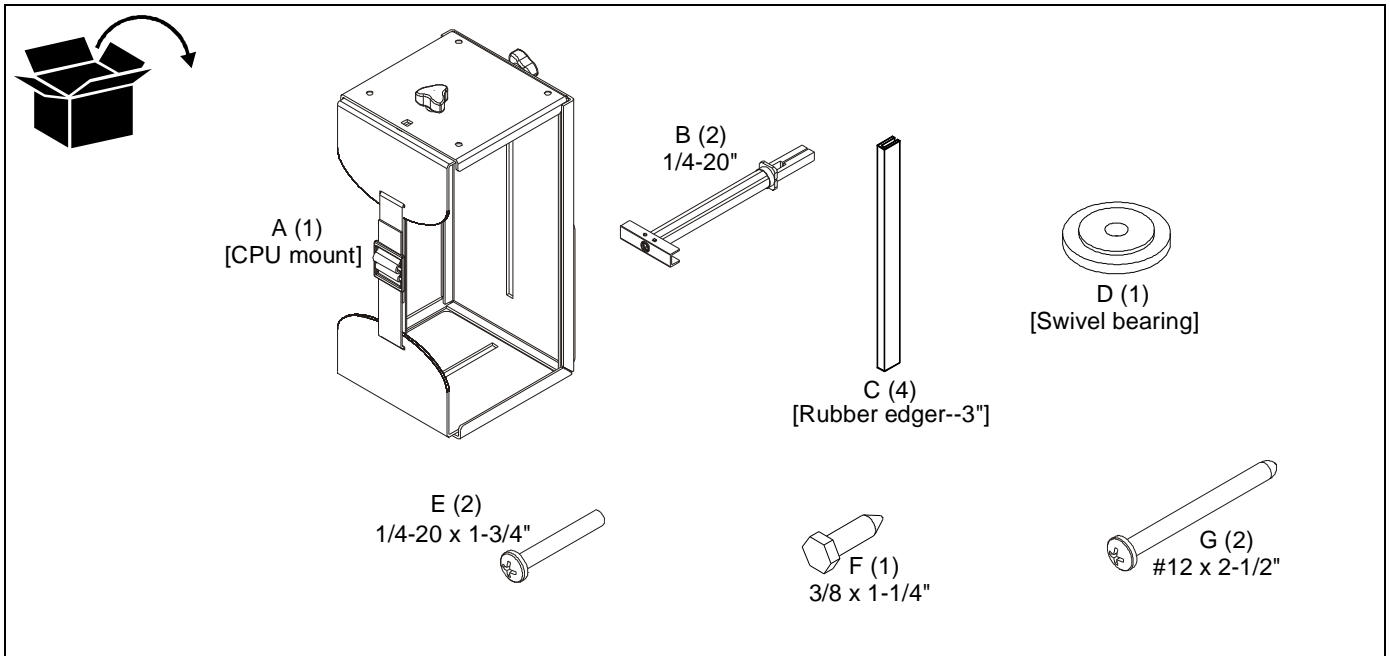

ASSEMBLY

Installation of Protective Rubber Edging

1. Place four strips of protective rubber edging (C) over the sharp edges located on the top and bottom of the mount (A). (See Figure 1)

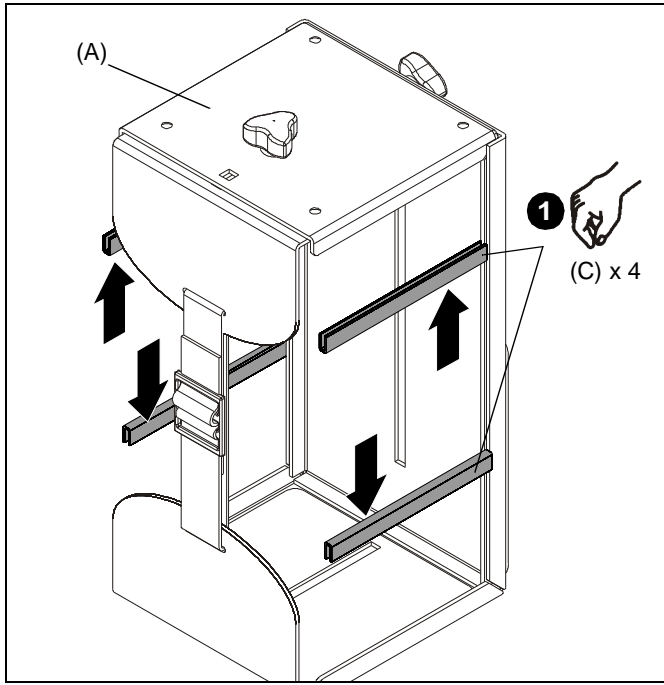

Figure 1

CPU Installation

1. Release bracket from mount by moving flag to open position. (See Figure 2)
2. Remove bracket from mounting buttons on back of mount. (See Figure 2)

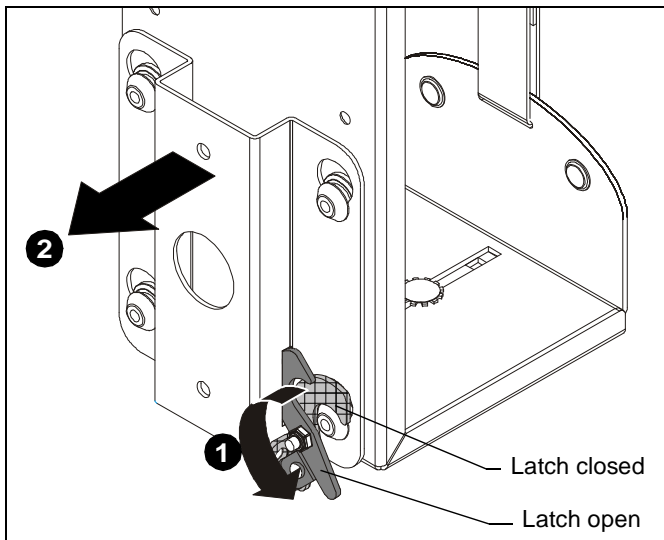

Figure 2

3. If hanging mount underneath desk, remove mounting buttons to reinstall them in the holes in which they will be used.
 - If mounting vertically, move mounting buttons to the four holes on top of the mount. (See Figure 3)
 - If mounting horizontally, move mounting buttons to the top four holes on the back. (See Figure 3)

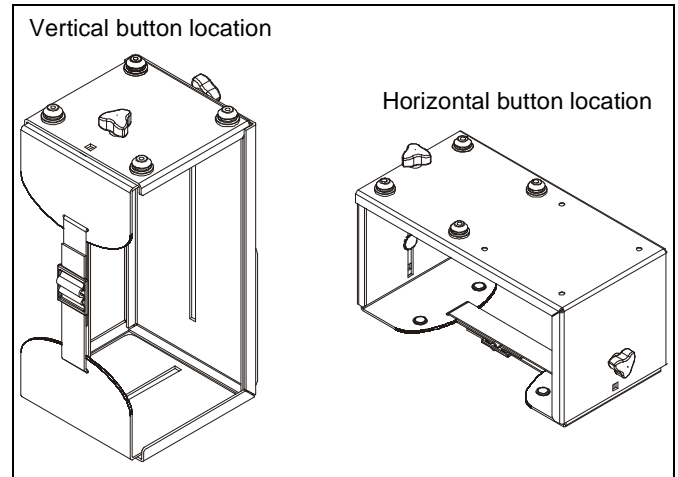

Figure 3

4. Loosen adjustment knob at the back of the mounting unit and adjust height of mount to a height greater than the height of the CPU. Loosen strap at the front of the mount if necessary. (See Figure 4)

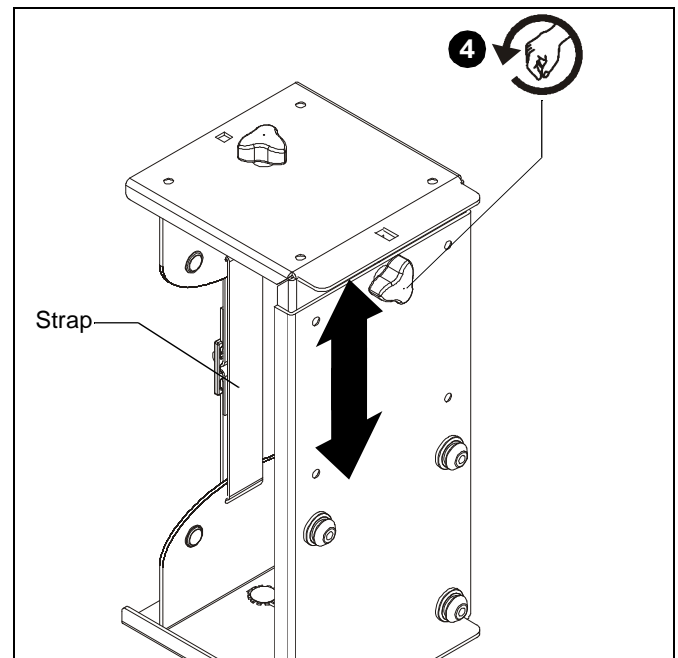

Figure 4

- Loosen adjustment knobs on top and bottom of the mount and slide flanges in order to allow for the CPU to be inserted for mounting. (See Figure 5)

NOTE: Top and bottom knobs can be removed and inserted into the front square holes in order to allow for large CPU's to be installed. (See Figure 5)

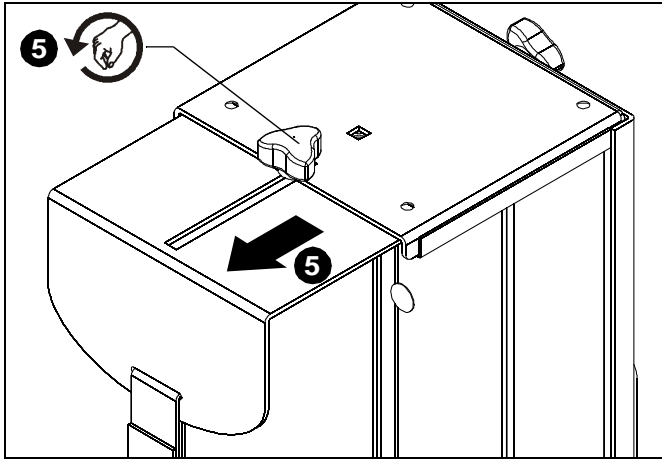

Figure 5

NOTE: Flanges may be reversed in order to allow for narrow CPU's to be installed in a secure manner.

- Remove top and bottom knobs. (See Figure 6)
- Remove top and bottom flanges.
- Turn flanges around and re-insert into mount.
- Remove and reinstall strap so that the buckle is facing out to allow easy adjustment. (See Figure 6)
- Reinstall top and bottom knobs. (See Figure 6)

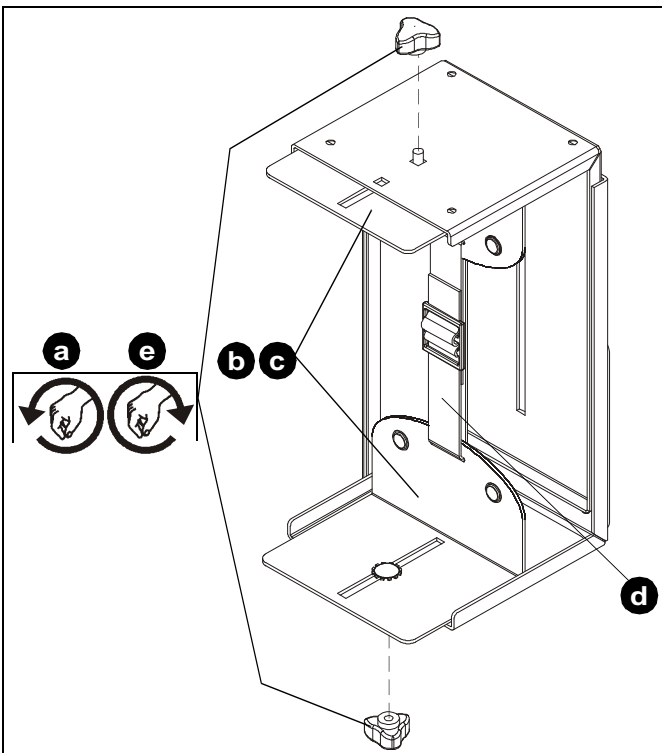

Figure 6

- Set CPU in CPU mount (A). (See Figure 7)
- Use adjustment knobs to compress mount around CPU until CPU is tightly secured in mount (A). (See Figure 7)

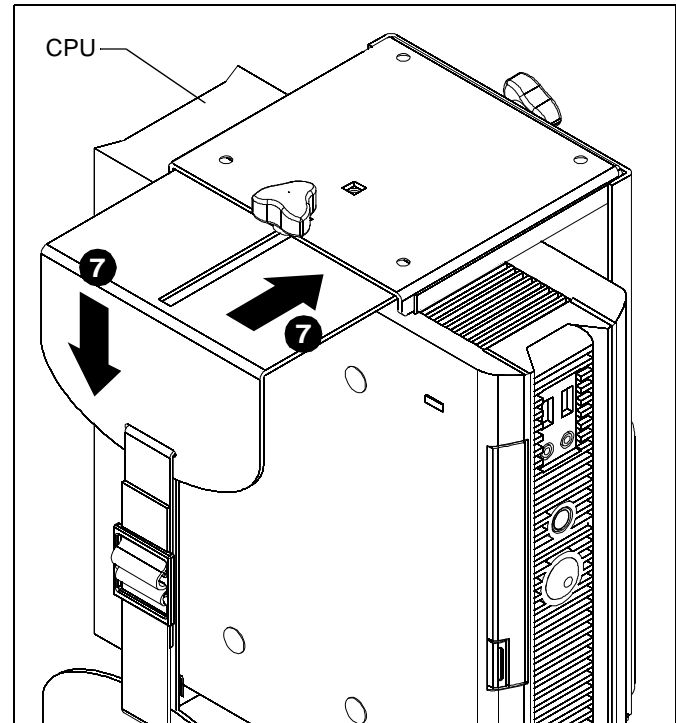

Figure 7

- Tighten front strap to desired tension.

WALL MOUNT INSTALLATION



WARNING: FAILURE TO PROVIDE ADEQUATE STRUCTURAL STRENGTH FOR THIS MOUNT CAN RESULT IN SERIOUS PERSONAL INJURY OR DAMAGE TO EQUIPMENT! It is the installer's responsibility to make sure the structure to which this mount is attached can support five times the combined weight of the mount and all equipment attached to it. Reinforce the structure as required before installing the mount.

NOTE: Mount may be installed using 2" x 4" wood studs, steel studs or it may be installed directly into drywall. For steel stud and drywall installation, proceed to **Site Requirements for Using Steel Studs** section. For desk mounting, proceed to **Installing Mount to Desk** section.

Installing to Wood Studs

- Determine location for mount keeping in mind CPU size and safety requirements.
- Use the removed mounting bracket as a template and mark through top and bottom holes of wall bracket. (See Figure 7)

3. Drill two 7/64" diameter pilot holes at marked spots into wood stud. (See Figure 8)

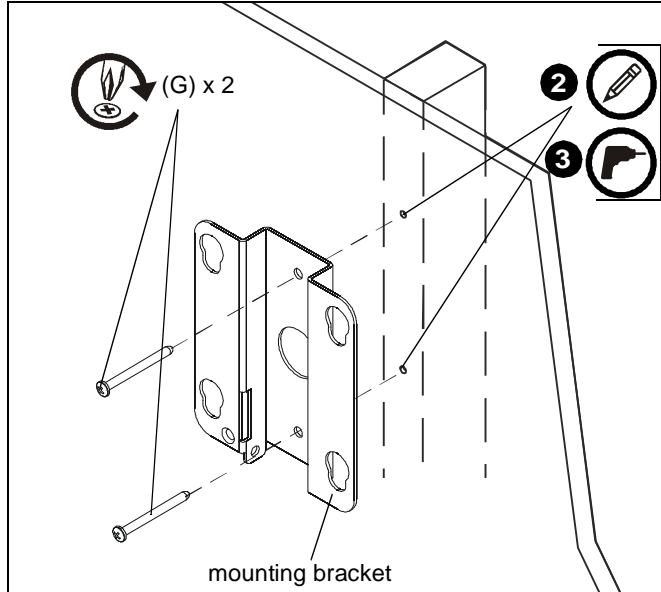

Figure 8

4. Install two #12 x 2-1/2" Phillips wood screws (G) through bracket and drywall into wood stud. (See Figure 8)
5. Ensure bracket is vertical, then tighten screws (G).

NOTE: Proceed to **Installing CPU Mount to Wall** section to complete installation.

Site Requirements for Using Steel Studs

⚠ WARNING: IMPROPER INSTALLATION CAN LEAD TO EQUIPMENT FALLING CAUSING SERIOUS PERSONAL INJURY OR DAMAGE TO EQUIPMENT! The figure below identifies the minimum requirements for installation of display mounts onto a steel stud structure. If the structure or its components do not meet these requirements contact the mount manufacturer for specific instructions before attempting installation. It should also be noted that no other equipment should be mounted to the same stud.

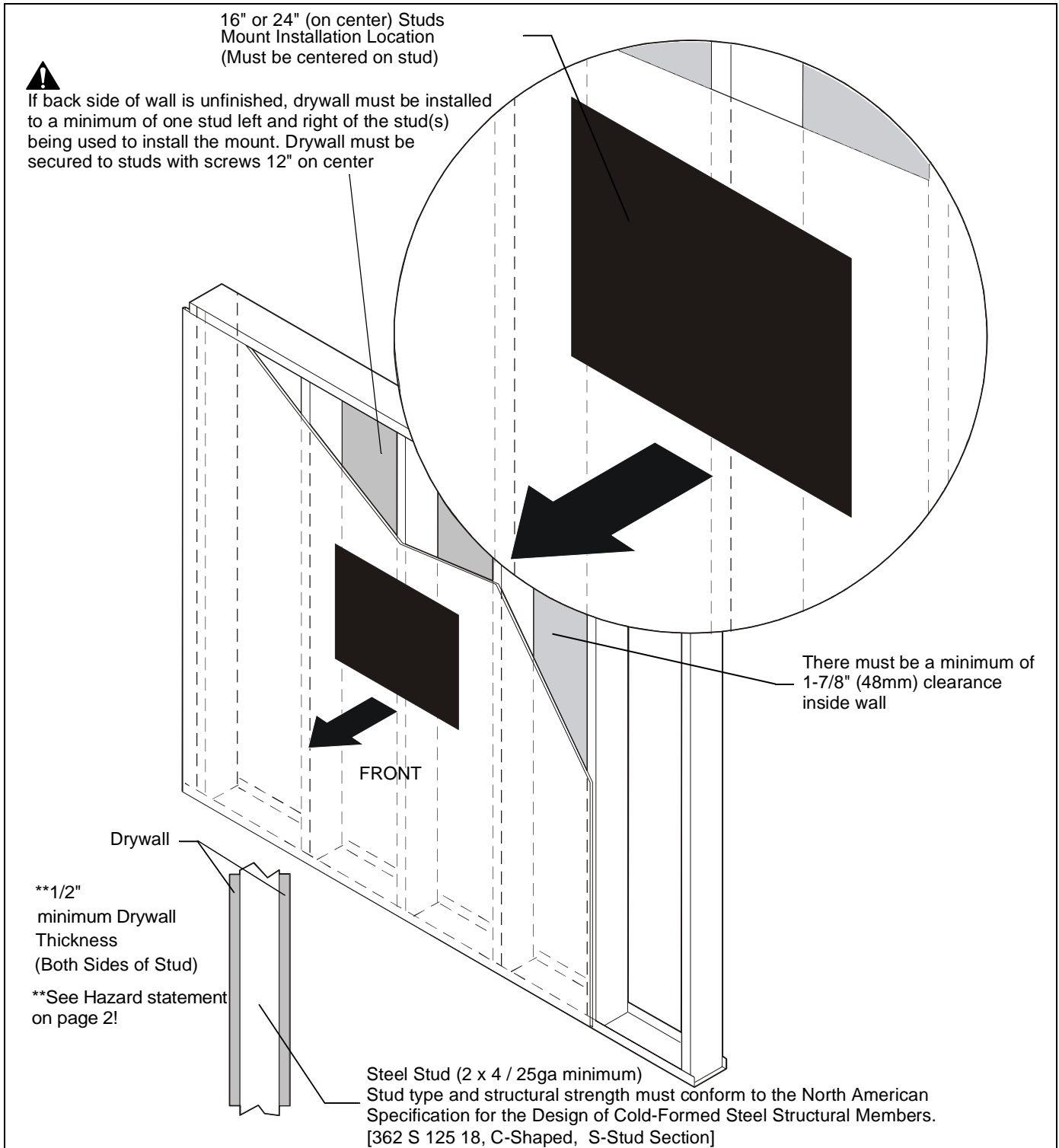

Figure 9

Installing to Steel Studs or Drywall



WARNING: IMPROPER INSTALLATION CAN LEAD TO EQUIPMENT FALLING CAUSING SERIOUS PERSONAL INJURY OR DAMAGE TO EQUIPMENT!

1. Determine location for mount keeping in mind CPU size and safety requirements.
2. Use the removed mounting bracket as a template and mark through top and bottom holes of wall bracket making sure mounting holes are centered on stud. (See Figure 10)
3. Drill two 1/2" diameter pilot holes at marked spots into wood stud. (See Figure 10)

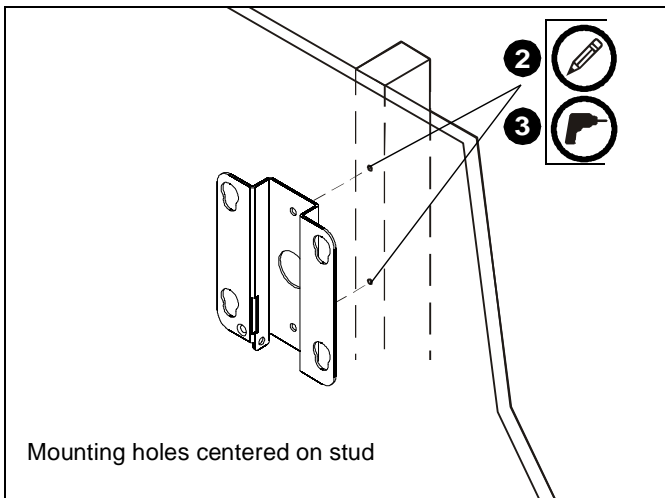

Figure 10

4. Hold metal channel on anchor (B) flat alongside plastic straps and slide channel through hole. (See Figure 11)

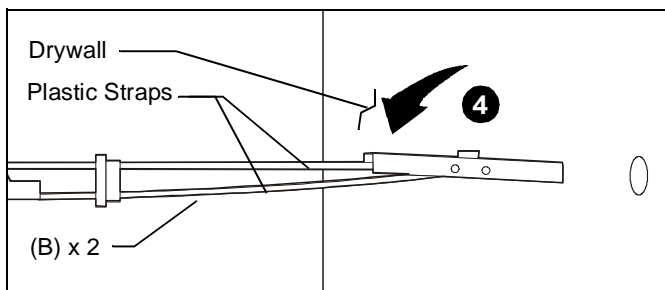

Figure 11

5. Holding plastic straps on anchor (B), pull anchor away from wall until channel rests flush behind wall making sure anchor channel is positioned vertically on stud. (See Figure 12)
6. Slide plastic cap on anchor (B) towards wall until flange of cap is flush with wall. (See Figure 12)

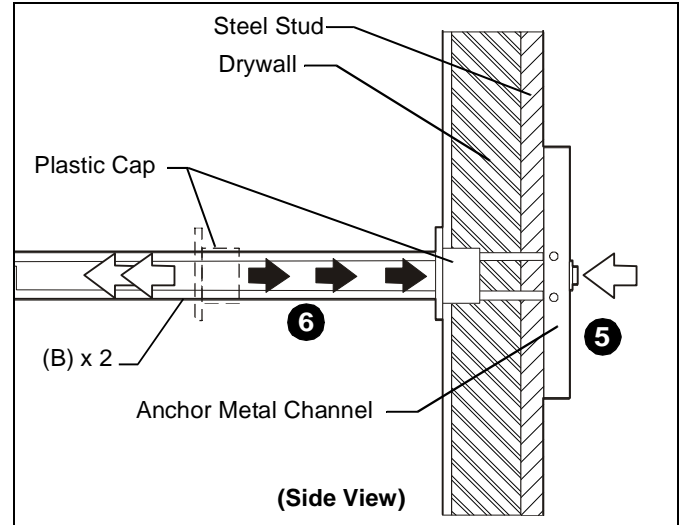

Figure 12

7. Snap off plastic straps on anchor at wall by pushing side to side, snapping off straps level with flange of plastic cap. (See Figure 13)
8. Repeat Steps 4 through 7 for remaining mounting hole.

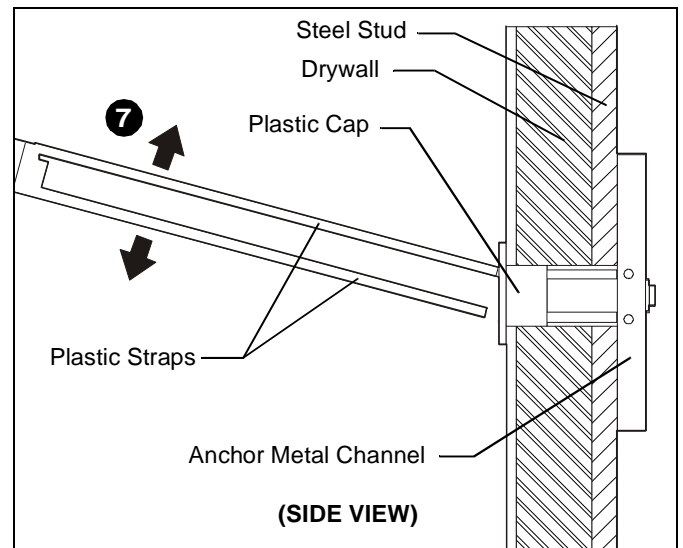

Figure 13

9. Place mounting bracket over anchors and align mounting holes in mounting bracket with holes in anchors. (See Figure 14)
10. Insert 1/4-20 x 1-3/4" Phillips pan head screw (E) into mounting hole on mounting bracket and into anchor (B) and tighten until flush against mounting bracket. DO NOT overtighten! (See Figure 14)
11. Repeat Steps 9 and 10 for remaining mounting hole.

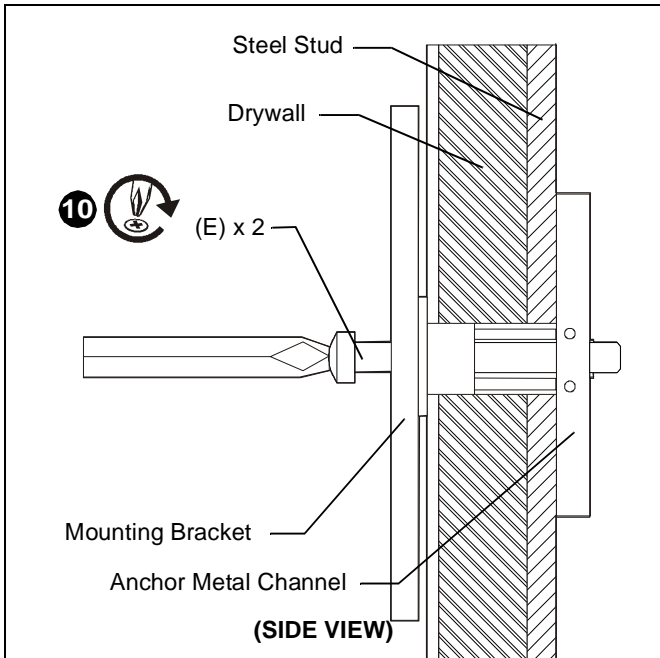

Figure 14

Installing CPU Mount to Wall



CAUTION: Overtightening screws may cause wall bracket to compress into soft wall surface resulting in difficult mount installation.

1. Ensure bracket flag is in the open position. (See Figure 16)
2. Insert mounting buttons into the four large mounting holes on the bracket and lower into place. (See Figure 15)

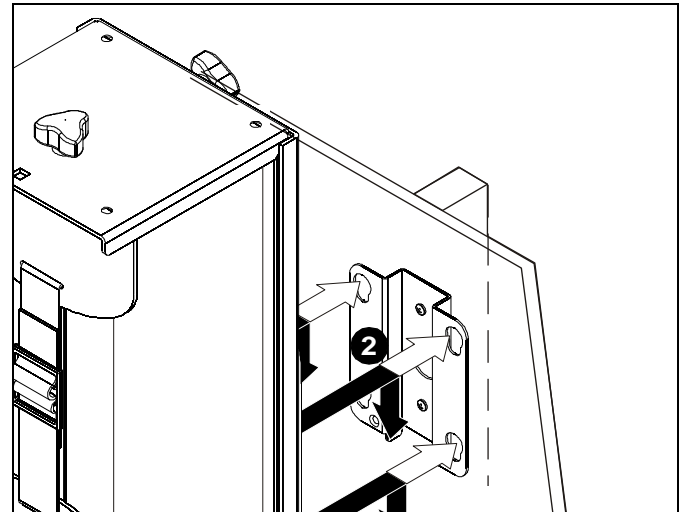

Figure 15

3. Move flag to closed position in order to fully secure mount to bracket. (See Figure 16)

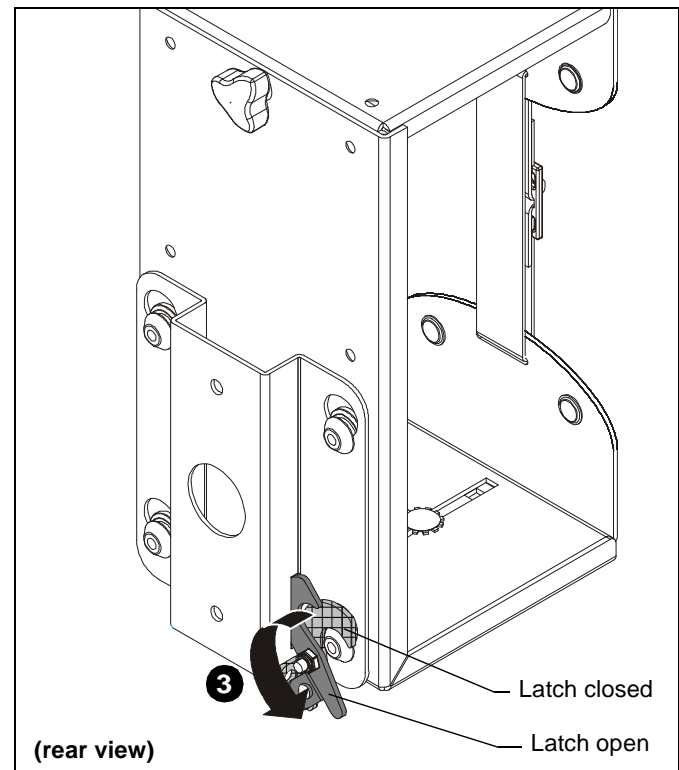

Figure 16

Installing Mount to Desk



WARNING: Failure to provide adequate structural strength for this component can result in serious personal injury or damage to equipment! It is the installer's responsibility to make sure the desk to which this component is attached can support five times the combined weight of all equipment. Reinforce the structure as required before installing the component.

NOTE: The following instructions are for mounting with full 360° swivel capability for easy cord access. If this capability is not desired, connect mounting bracket using two screws as demonstrated in the **Installing to Wood Studs** section.

1. Determine location for mount keeping in mind CPU size and safety requirements.
2. Using bracket and swivel bearing (D) as a template, mark and drill one 17/64" diameter pilot hole through underside of desk at desired mounting location. Ensure entire mount will clear the outer edge of desk. (See Figure 17)

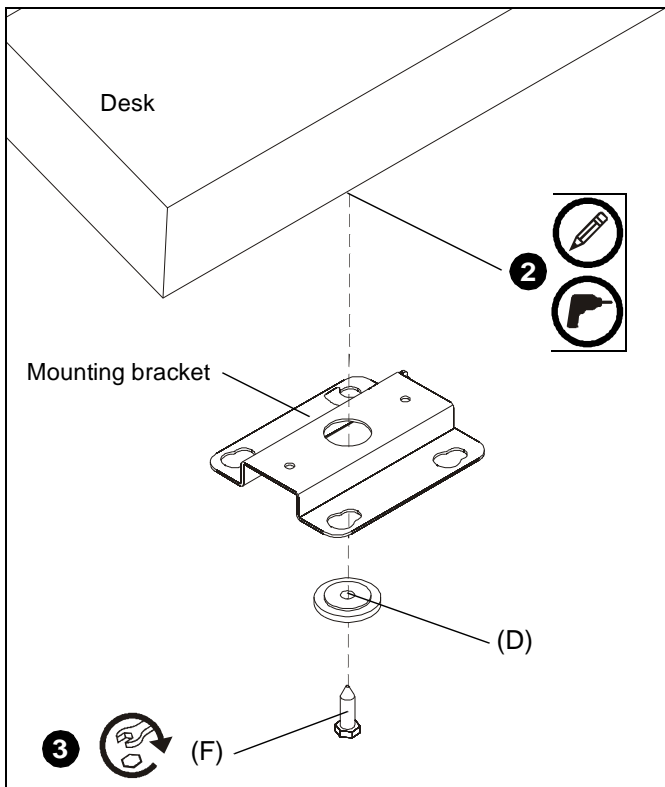

Figure 17

3. Install 3/8 x 1-1/4" hex head lag screw (F) through bearing (D) and mounting bracket into hole drilled in Step 2. (See Figure 17)
4. Ensure bracket flag is in the open position. (See Figure 16)
5. Insert four mounting buttons into four mounting holes on the bracket. (See Figure 18)

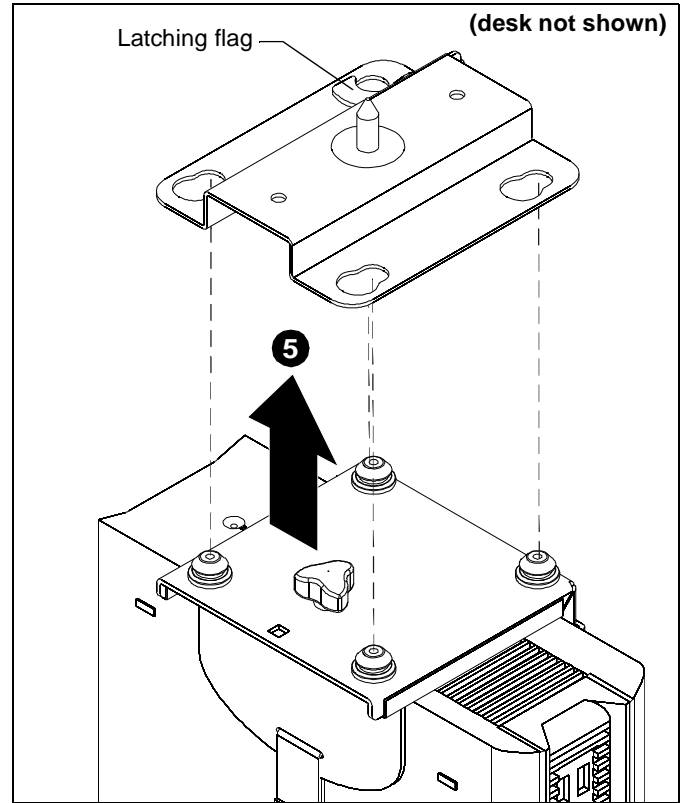

Figure 18

6. Slide buttons into locked position within holes.
7. Move flag to closed position in order to fully secure mount to bracket. (See Figure 16)



Our Mounts. **Your Vision.**

Chief Manufacturing, a products division of
Milestone AV Technologies

8834-002003 Rev01

©2012 Milestone AV Technologies, a

Duchossois Group Company

www.chiefmfg.com

03/12

USA/International	A 6436 City West Parkway, Eden Prairie, MN 55344
	P 800.582.6480 / 952.225.6000
	F 877.894.6918 / 952.894.6918
Europe	A Franklinstraat 14, 6003 DK Weert, Netherlands
	P +31 (0) 495 580 852
	F +31 (0) 495 580 845
Asia Pacific	A Office No. 1 on 12/F, Shatin Galleria 18-24 Shan Mei Street Fotan, Shatin, Hong Kong
	P 852 2145 4099
	F 852 2145 4477

