

**ASSEMBLY INSTRUCTIONS**  
**COASTER FINE FURNITURE**

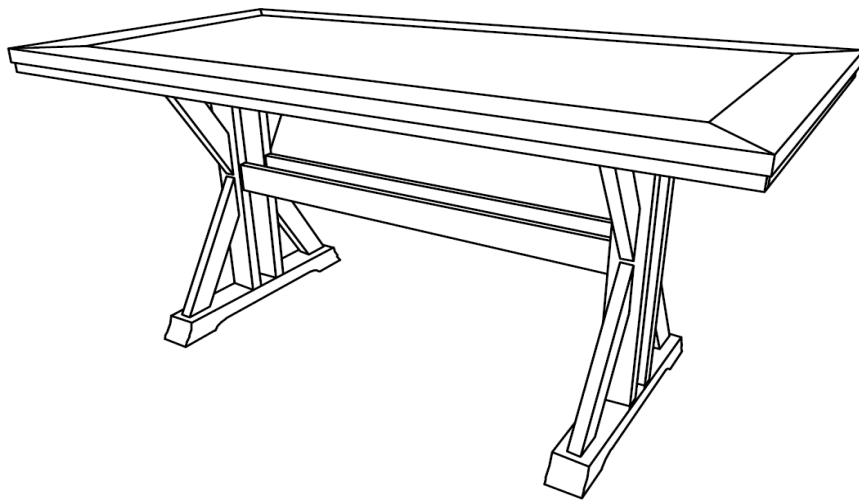

*Fine Furniture for every stage of life*

**193498(B1&B2)**  
**Counter Height Table**

# ITEM: 193498(B1&B2)



## ASSEMBLY INSTRUCTIONS

### ASSEMBLY TIPS:

1. Remove hardware from box and sort by size.
2. Please check to see that all hardware and parts are present prior to start of assembly.
3. Please follow attached instructions in the same sequence as numbered to assure fast & easy assembly.



### WARNING!

1. Don't attempt to repair or modify parts that are broken or defective. Please contact the store immediately.
2. This product is for home use only and not intended for commercial establishments.





ASSEMBLY TIME

20 MINUTES

## PARTS IDENTIFICATION

### B1 (BOX 1)







A	TOP		1PC
B	CROSSBAR		2PCS

### B2 (BOX 2)

C	LEG FRAME		2PCS
---	-----------	--	------

## HARDWARE IDENTIFICATION

### Z-B1 (BOX 1) - HARDWARE PACK IS LOCATED IN 193498 (B1)

1	ALLEN WRENCH (M5 - BLK)		1PC
2	BOLT (M6 x 90mm - RBW)		8PCS
3	LOCK WASHER (M6 x RBW)		8PCS
4	PLASTIC DOWEL (M8 x 30mm - BLK)		4PCS
5	WAFFER HEAD SCREW (M4 x 25mm - BLK)		16PCS
6	WOOD PLUG		8PCS
7	LEVELER (23mm - BLK)		4PCS

### NOTE:

Phillips head screw driver is required in the assembly process; however, manufacturer does not provide this item.

ITEM: 193498(B1&B2)



ASSEMBLY INSTRUCTIONS

**STEP 1**

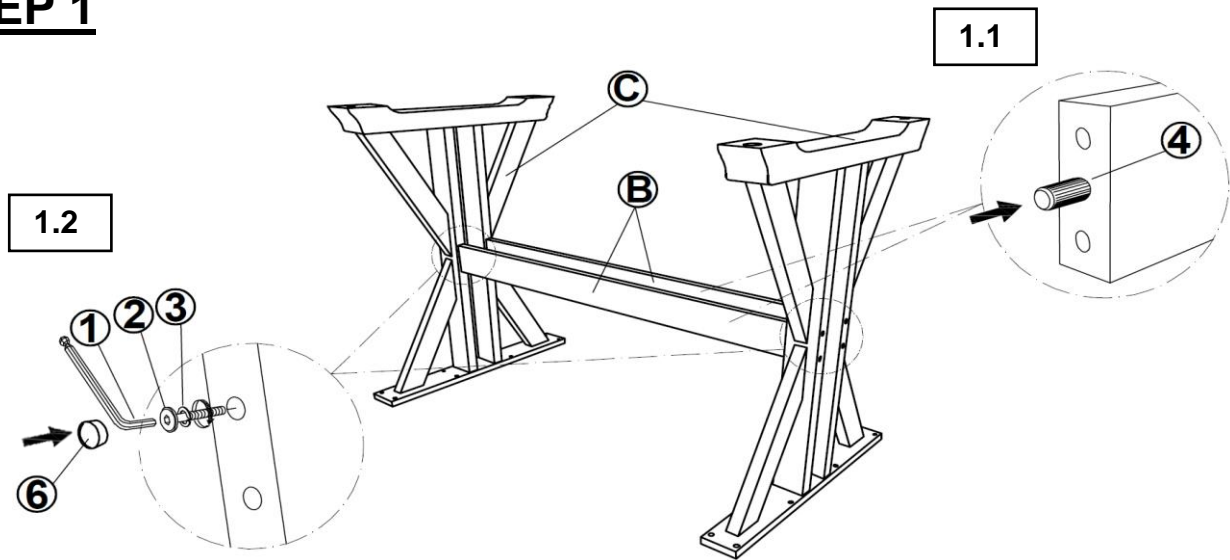

**STEP 2**

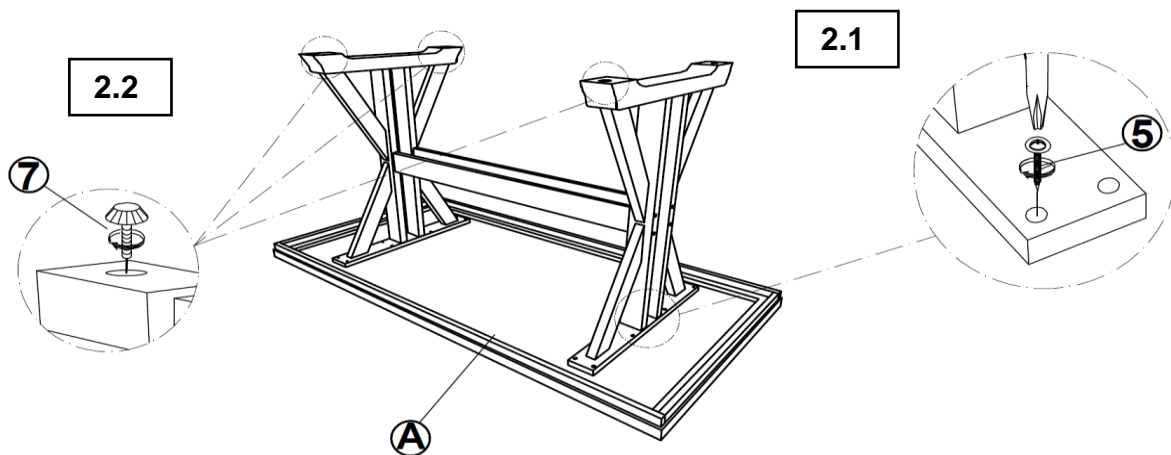

**STEP 3**

**COMPLETE**

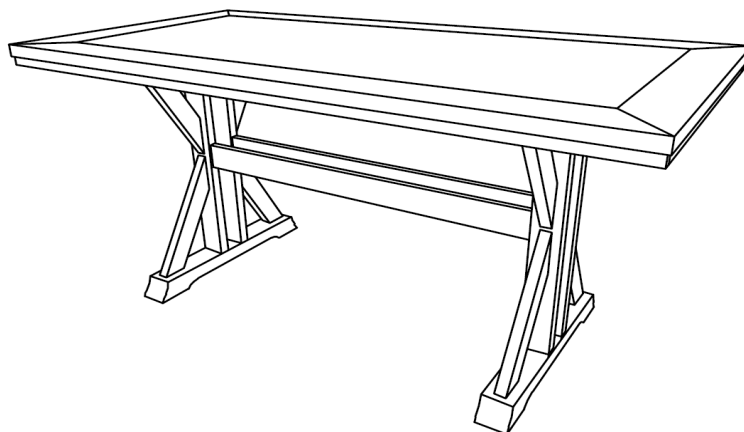

ITEM: 193498(B1&B2)

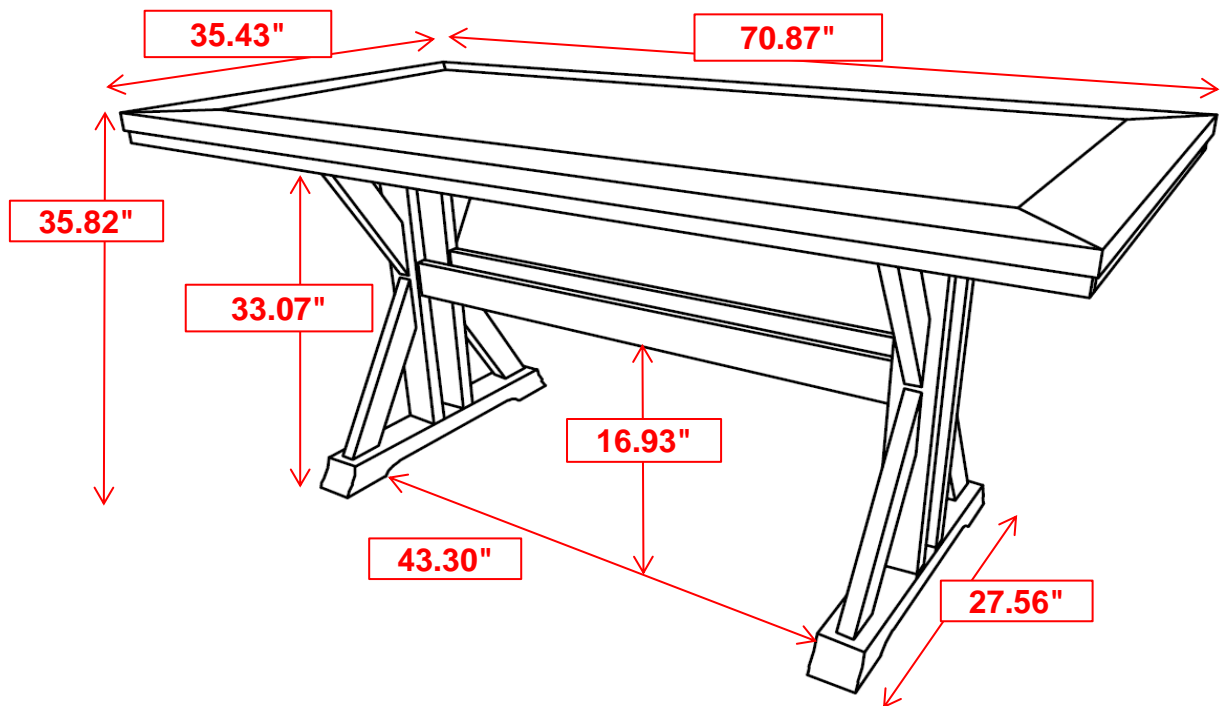

**Note :** Dimension tolerance  $\pm 5\%$