

- Signature Blue interior
- Full wrapped stainless-steel exterior
- 2 full-extension stainless steel lined drawers
- Multi function capacitive touch electronic control
- Temperature range: 34°F to 65°F
- Fan-assisted cooling system allows for even temperatures, quicker cooldown times, and added efficiency
- Full LED theater lighting
- Adaptable stainless steel dividers in each drawer allows customization of drawer space
- Stainless model includes 1" diameter stainless steel handles with faceted standoffs (22" length)
- Panel Ready model requires ¾" custom door panel and handle
- 4 independent adaptable leveling legs
- Adaptable grille accepts an integrated toe kick and allows front/back and up/down alignment with adjacent cabinetry and toe kick/plinth
- Automatic defrost
- Lock model available



Stainless



Panel Ready



Stainless with Lock

Model Details

Model	Lock	Finish	Description	Shipping Weight
YRD24-SS	No	Stainless Steel	24" Indoor Refrigerator Drawers	157 lbs

Dimensions/Weight	Detail
Product Depth	23 ¼"
Product Height	34" - 35"
Product Width	23 ¾"
Product Weight	127 lbs
Product Volume	4.6 cu ft
Shipping Dimensions	26 ¾" x 27 ½" x 36 ¾"
Shipping Weight	157 lbs

Integration/Panel Information*	Detail
Panel Height	2 Panels: 14 ¾" each
Panel Thickness	¾" - 20 mm
Panel Width	23 ¾"

*Refer to manual for all panel dimensions and installation instructions

Model	Details
Control Type	Electronic Capacitive Touch with OLED Screen
Indoor or Outdoor	Indoor
Built-in Installation	Inset, Frameless / Overlay and Framed Cabinet Styles
Refrigerant Type	R600

Electrical	Details
Electrical Requirements	115 V / 60 Hz
Volt Range	104 V ~ 127 V
Maximum Amp Fuse	15 amp
Amps Running	0.7 amps

Approvals - Certifications	Details
ETL Residential / Commercial	Yes
ETL Sanitation	Yes
Star K	Yes

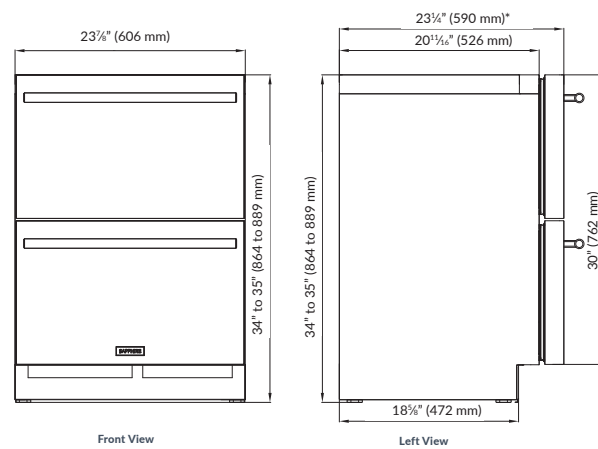
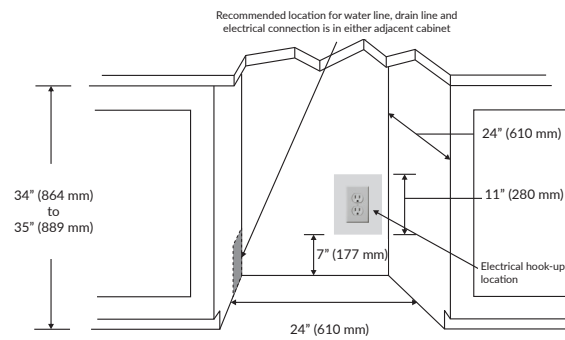

*Dimensions are the same for Panel Ready unit when 3/4" panel applied

