

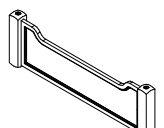

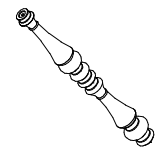

Hardware and Parts packed with the 21585 King Poster Footboard



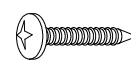
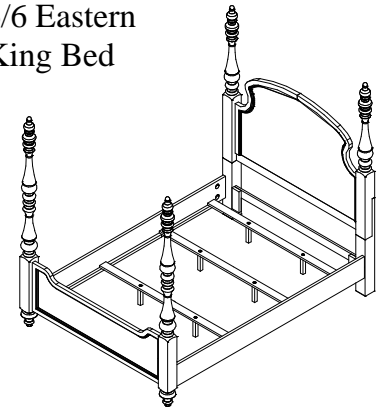

<p>King Footboard Panel</p>  <p>(F-A) 1 pc.</p>	<p>Upper Post</p>  <p>(F-B) 2 pcs.</p>	<p>Post Top Finial</p>  <p>(F-C) 2 pcs.</p>	<p>Post Bun Foot</p>  <p>(F-D) 2 pcs.</p>
<p>6/0-6/6 Wood Slat 76-7/8" Long</p>  <p>(F-E) 4 pcs.</p>	<p>Slat Support Leg 7-7/8" long with leveler</p>  <p>(F-F) 8 pcs.</p>	<p>#8 x 1" Wood Screw</p>  <p>(F-G) 8 pcs.</p>	

6/6 Eastern King Bed

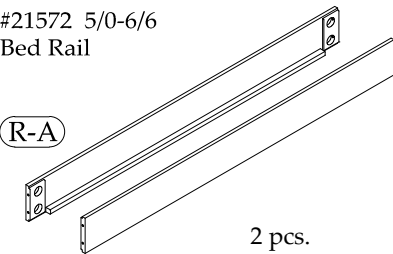
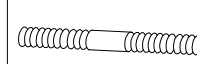

- 21584 6/0-6/6 Poster Headboard
- 21585 6/0-6/6 Poster Footboard
- 21572 5/0-6/6 Bed Rails

Hardware and Parts packed with the 21572 5/0-6/6 Bed Rails

<p>#21572 5/0-6/6 Bed Rail</p>  <p>(R-A) 2 pcs.</p>	<p>M5/16" x 4-1/2" All-Thread Bolt</p>  <p>(R-B) 8 pcs.</p>	<p>Ø5/16" Hex Nut</p>  <p>(R-C) 8 pcs.</p>
<p>M5/16" Spring Washer</p>  <p>(R-D) 8 pcs.</p>	<p>Curved Washer 32 L x 13 x 8mm</p>  <p>(R-E) 8 pcs.</p>	<p>12mm Open Wrench</p>  <p>(R-F) 8 pcs.</p>

Be sure to check all packing material carefully for small parts, which may have come loose inside the carton during shipment. To prevent possible scratches or damage, this furniture should be assembled on a soft surface such as a blanket or carpet.

STEP 2
Assemble Upper Posts to top of Footboard

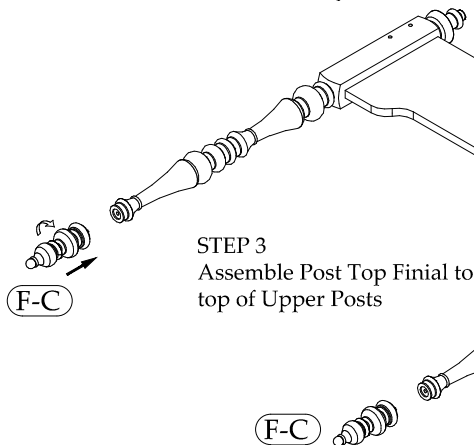
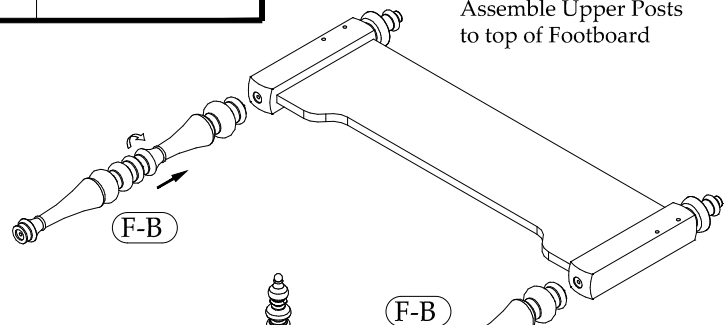
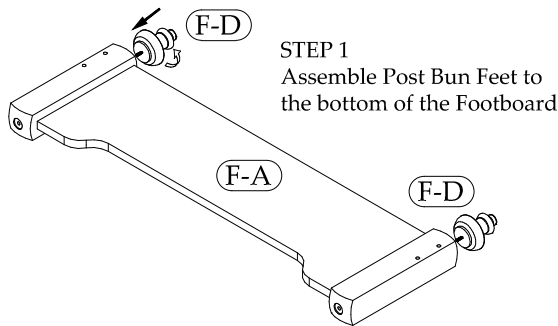

STEP 4
Footboard Assembly is complete

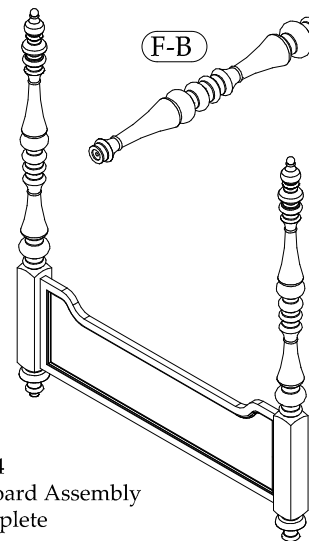

6/6 Eastern
King Bed

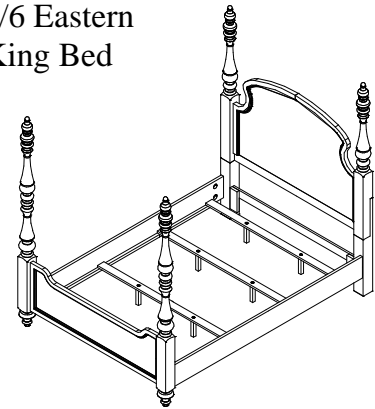

- 21584 6/0-6/6 Poster Headboard
- 21585 6/0-6/6 Poster Footboard
- 21572 5/0-6/6 Bed Rails



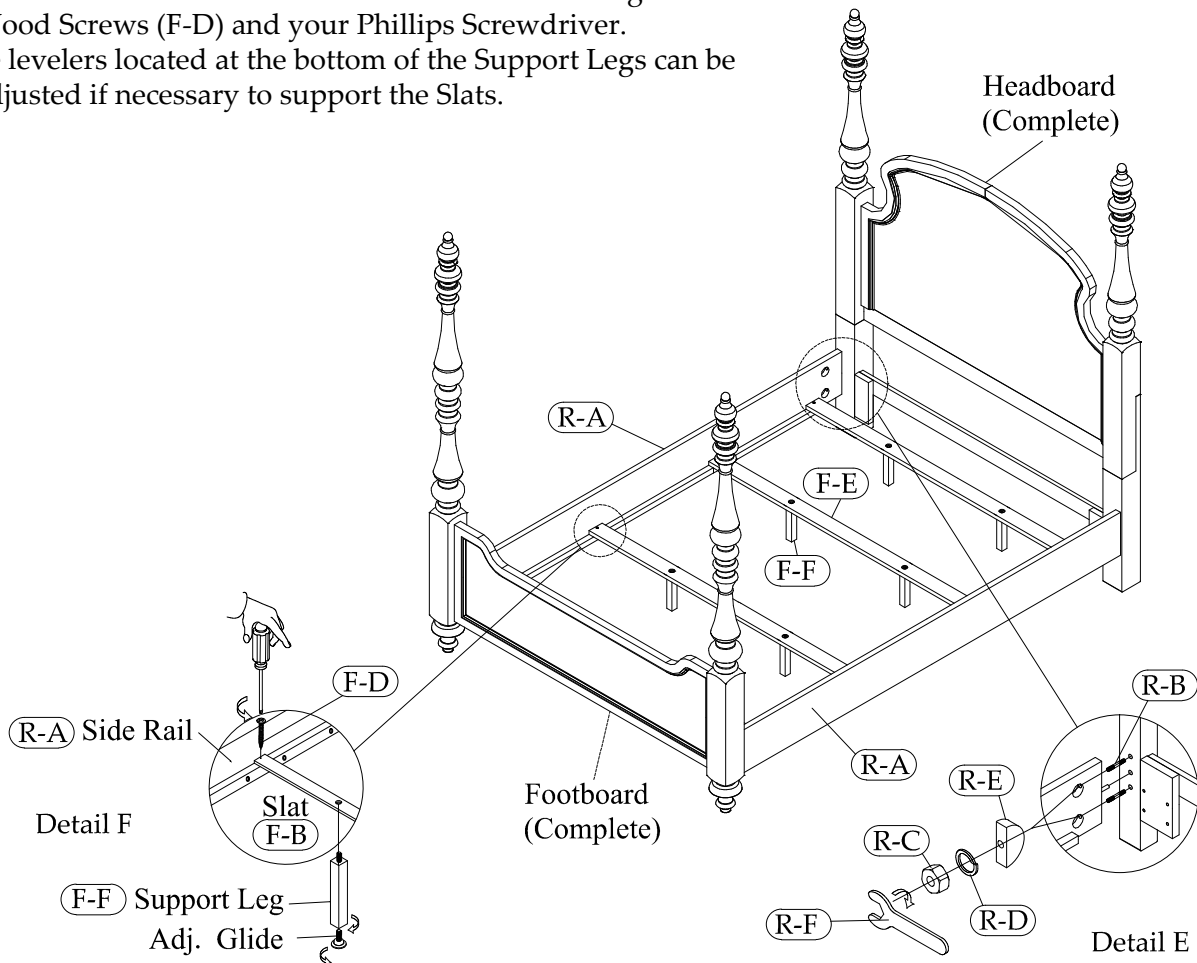

ASSEMBLY STEPS :

To prevent possible damage to furniture and personal injury, it is recommended that two people are used to perform the following steps.

5. Install two All-Thread Bolts (R-B) into the metal threaded inserts installed in the completed Headboard Legs and into the metal inserts on the completed Footboard.
 6. Carefully position one end of one Bed Rail (R-A) onto the All-thread Bolts on the Headboard and connect using the Curved Washers (R-E), Spring Washers (R-D), and Hex Nut (R-C). Only partially tighten the Nuts until the Footboard has been connected. Repeat for other Bed Rail.
 7. Position and connect the completed Footboard (F-A) to the other end of the Bed Rails, attaching as in the previous Steps.
 8. Carefully align the Footboard to be 'square' with the Headboard. Using the Open Wrench (R-F) tighten all Hex Nuts attaching the Side Rails to the Headboard and Footboard. (See Detail E).
 9. Attach the four Support Legs (F-C) to the bottom side of four Wood Slats (F-B). (See Detail F).
 10. Position and attach the Slats to the Bed Rails using the Wood Screws (F-D) and your Phillips Screwdriver.
- The levelers located at the bottom of the Support Legs can be adjusted if necessary to support the Slats.

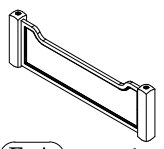
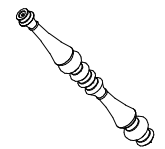

Hardware and Parts packed with the 21585 King Poster Footboard

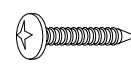



<p>King Footboard Panel</p>  <p>(F-A) 1 pc.</p>	<p>Upper Post</p>  <p>(F-B) 2 pcs.</p>	<p>Post Top Finial</p>  <p>(F-C) 2 pcs.</p>	<p>Post Bun Foot</p>  <p>(F-D) 2 pcs.</p>
<p>6/0-6/6 Wood Slat 76-7/8" Long</p>  <p>(F-E) 4 pcs.</p>	<p>Slat Support Leg 7-7/8" long with leveler</p>  <p>(F-F) 8 pcs.</p>	<p>#8 x 1" Wood Screw</p>  <p>(F-G) 8 pcs.</p>	

6/0 California King Bed

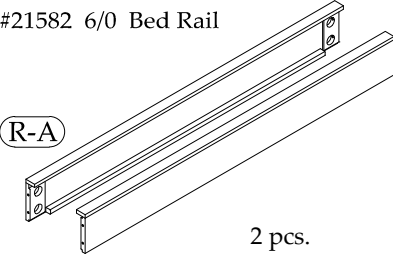
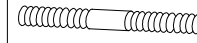

- 21584 6/0-6/6 Poster Headboard
- 21585 6/0-6/6 Poster Footboard
- 21582 6/0 Bed Rails

Hardware and Parts packed with the 21582 6/0 Bed Rails

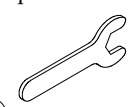
<p>#21582 6/0 Bed Rail</p>  <p>(R-A) 2 pcs.</p>	<p>M5/16" x 4-1/2" All-Thread Bolt</p>  <p>(R-B) 8 pcs.</p>	<p>Ø5/16" Hex Nut</p>  <p>(R-C) 8 pcs.</p>
<p>M5/16" Spring Washer</p>  <p>(R-D) 8 pcs.</p>	<p>Curved Washer 32 L x 13 x 8mm</p>  <p>(R-E) 8 pcs.</p>	<p>12mm Open Wrench</p>  <p>(R-F) 8 pcs.</p>

Be sure to check all packing material carefully for small parts, which may have come loose inside the carton during shipment. To prevent possible scratches or damage, this furniture should be assembled on a soft surface such as a blanket or carpet.

STEP 2
Assemble Upper Posts to top of Footboard

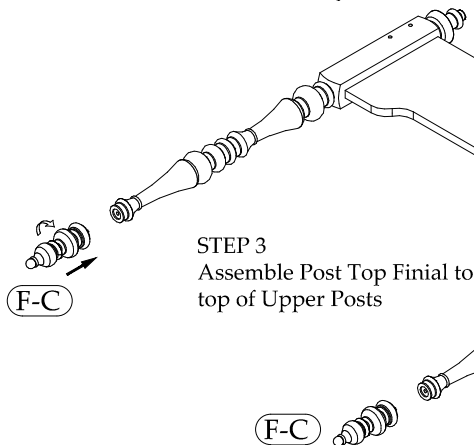
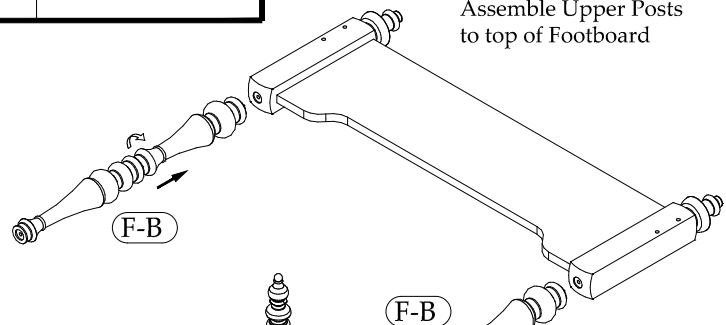
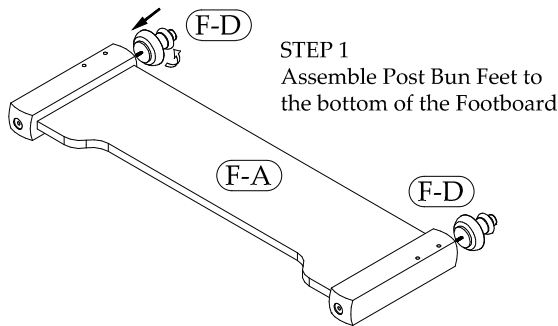

STEP 4
Footboard Assembly is complete

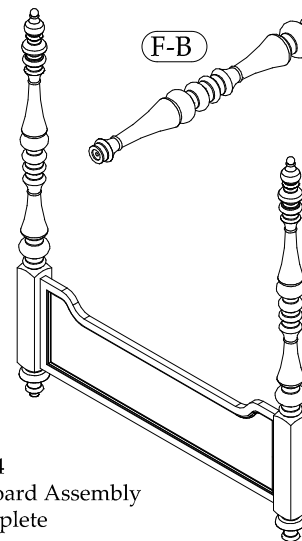

6/0 California King Bed



- 21584 6/0-6/6 Poster Headboard
- 21585 6/0-6/6 Poster Footboard
- 21582 6/0 Bed Rails

ASSEMBLY STEPS :

To prevent possible damage to furniture and personal injury, it is recommended that two people are used to perform the following steps.

5. Install two All-Thread Bolts (R-B) into the metal threaded inserts installed in the completed Headboard Legs and into the metal inserts on the completed Footboard.
 6. Carefully position one end of one Bed Rail (R-A) onto the All-thread Bolts on the Headboard and connect using the Curved Washers (R-E), Spring Washers (R-D), and Hex Nut (R-C). Only partially tighten the Nuts until the Footboard has been connected. Repeat for other Bed Rail.
 7. Position and connect the completed Footboard (F-A) to the other end of the Bed Rails, attaching as in the previous Steps.
 8. Carefully align the Footboard to be 'square' with the Headboard. Using the Open Wrench (R-F) tighten all Hex Nuts attaching the Side Rails to the Headboard and Footboard. (See Detail E).
 9. Attach the four Support Legs (F-C) to the bottom side of four Wood Slats (F-B). (See Detail F).
 10. Position and attach the Slats to the Bed Rails using the Wood Screws (F-D) and your Phillips Screwdriver.
- The levelers located at the bottom of the Support Legs can be adjusted if necessary to support the Slats.

