

MOVE

Version

FDMOV36W5SB / Built-in – 36"
(90 cm) Black – 500 CFM

Collection

Design

EAN code

8034122356327

FEATURES

- Sliding door
- Electronic control
- Metallic grease filter, removable and washable
- Optional combined regenerable Carbon.Zeo filter
- Possible to duct wall mounted from rear
- Optional Chimney
- Optional glass shelf
- Dynamic LED Light (2700K - 5600K)

Availability Carbon.Zeo filter KACL.961 for hoods produced from 02/05/2021
Recommended mounting height from cooking surface to hood bottom: 20"

OPTIONAL ACCESSORIES

FDNUVMTR600

FDNUVMTR600 - Motor 600 CFM

KACL.815

Protective cleaning cloths for stainless steel (box 10 pcs)

KACL.961

Charcoal and Zeolite filter

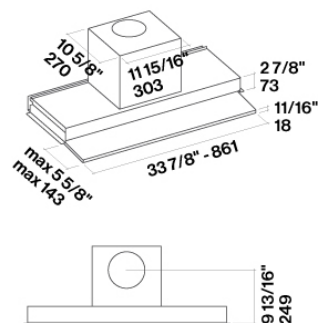

TECHNICAL FEATURES

Installation type

Built-in

Dimensions

36 / 90 cm

Finish

Scotch brite stainless steel (AISI 304)

Lower part in black tempered glass

Motor

500 CFM

Type of control

Electronic control

Speed settings

4

Lighting

Led 3x1,2 W - 3200 K

Filter

Metallic filter "Base" - 198x161 mm

Charcoal filter

Charcoal and Zeolite filter (optional)

Minimum distance

Gas hob: 21 in

Electric hob: 21 in

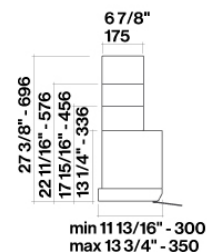

Optional chimney



Photograph is for information purposes only
May not correspond to the selected version

PACKAGING:WEIGHTS AND VOLUMES

Gross weight

45 lbs

Net weight

38 lbs

Volumes

7 ft³

Packaging size

Length

40 in

Height

17 in

Depth

19 in

CONSUMPTION AND CONNECTION FEATURES

Maximum consumption

280 W

Plug type

Hood comes standard with Nema 5-15P power cord

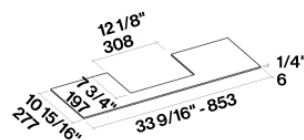

Optional shelf