

88 4508 95 Prep & Serve Cart



IMPORTANT NOTE

Carefully remove all the parts from the carton and put them individually on a soft cloth to prevent scratches or other damages occurring to the parts.

We have taken great care in the design of this product and request that you carefully and strictly follow our assembly instructions to ensure a completed product as it was designed.

PART LIST

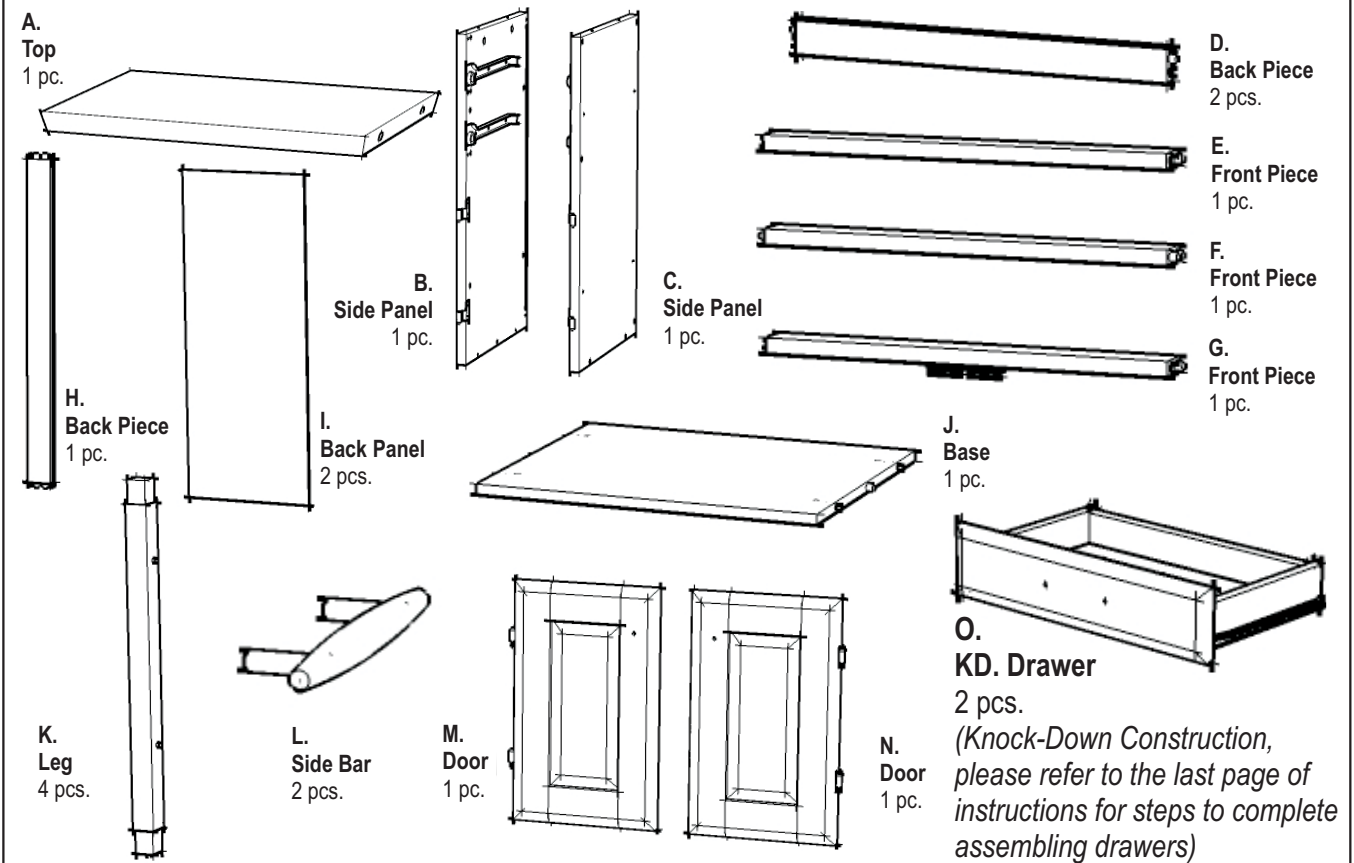

HARDWARE LIST



Tools Required For Assembly : Phillips screwdriver

Home Styles Consumer Assistance Line 888-680-7460 and 877-831-0319

servicedesk@homestyles-furniture.com

Revised date : 24Mar2011

Assembly Instructions 2/5

IMPORTANT

Do not tighten up all the screws until each part is properly assembled.
You should keep Hex Wrench in the safe place as you may need to tighten up the Head Cap Bolts in the future.

STEP 1

Attach Back Piece (D) to Side Panel (B) at the lower position with Head Cap Bolts.

Attach Back Piece (H) to Back Piece (D), then slide Back Panel (I) into place.

Attach Back Piece (D) to the unit at upper position.

Tighten the Head Cap Bolts.

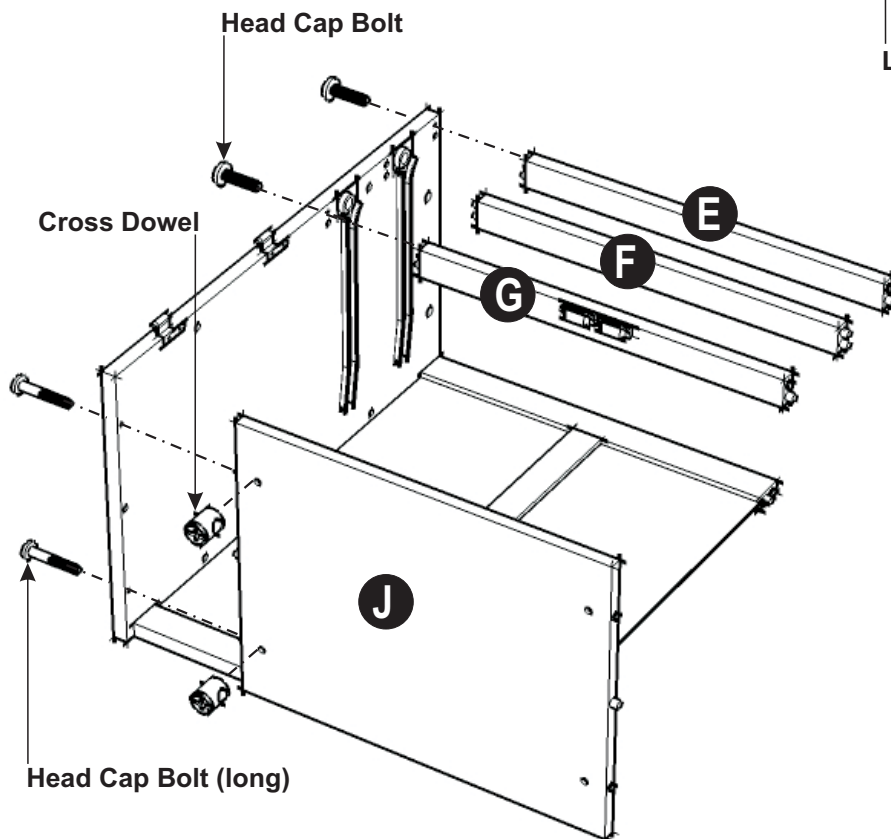
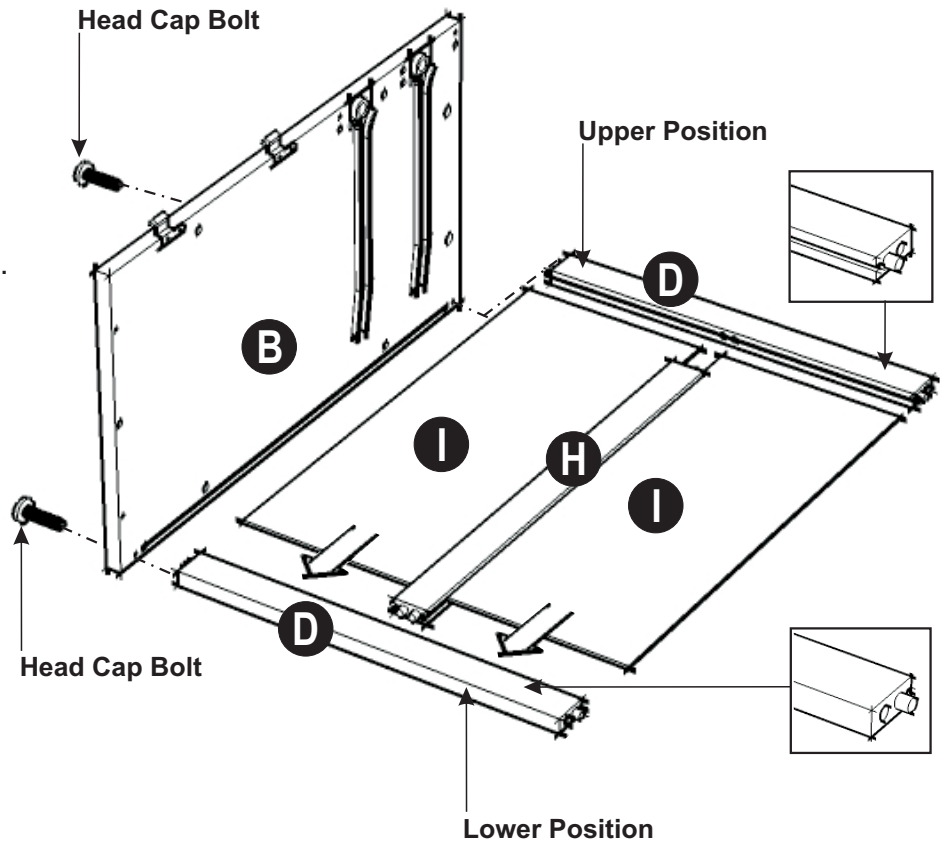

STEP 2

Attach Front Piece (E) and (G) to the unit with Head Cap Bolts.

Attach Front Piece (F) to the unit.

Attach Base (J) to the unit with Head Cap Bolts (long) and Cross Dowels.

STEP 3

Attach Side Panel (C) to the unit with Head Cap Bolts, Head Cap Bolts (long) and Cross Dowel.

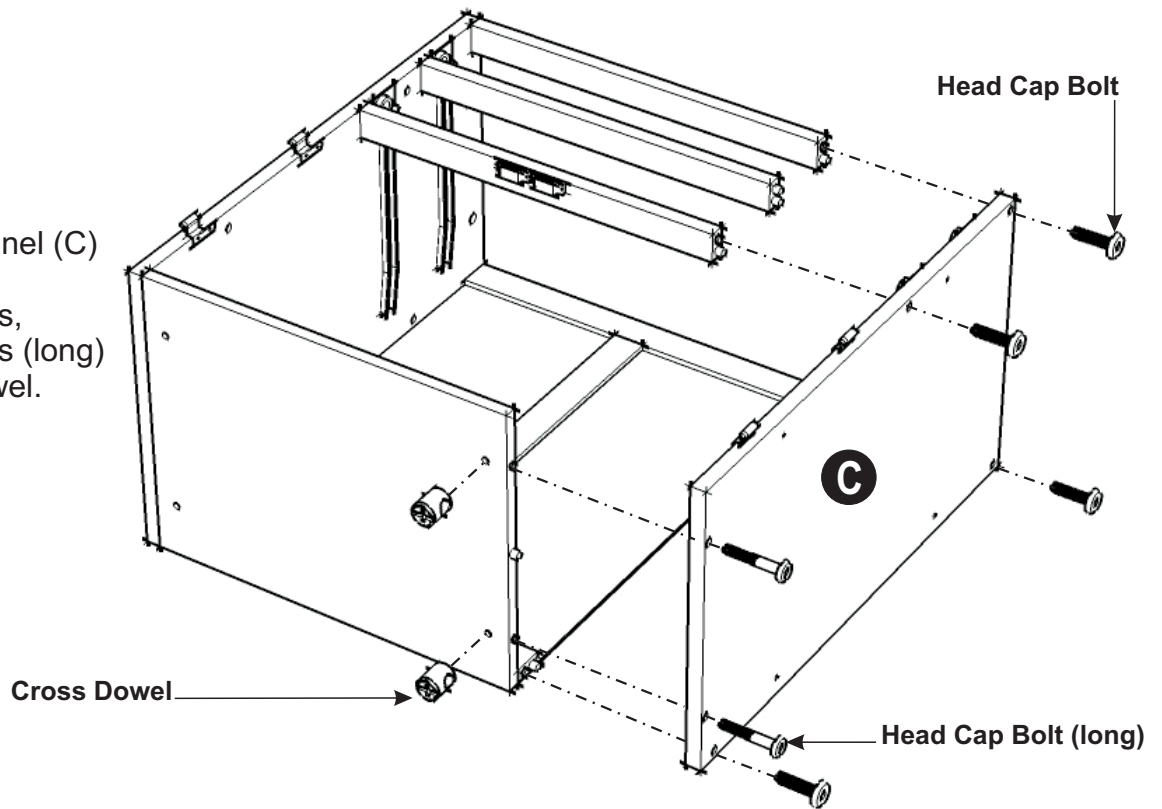

Locking Caster

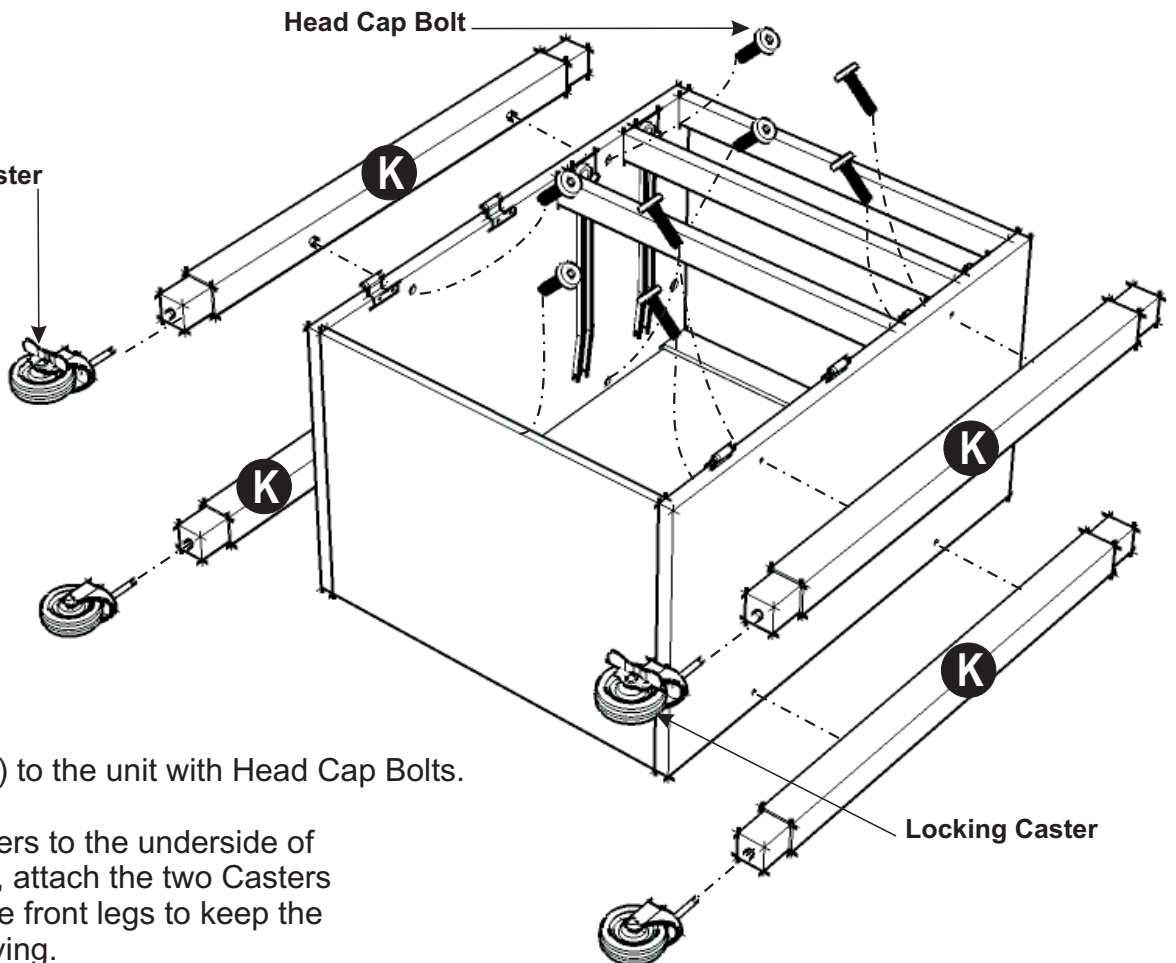

STEP 4

Attach Leg (K) to the unit with Head Cap Bolts.

Attach 4 Casters to the underside of the legs. First, attach the two Casters with lock to the front legs to keep the Cart from moving.

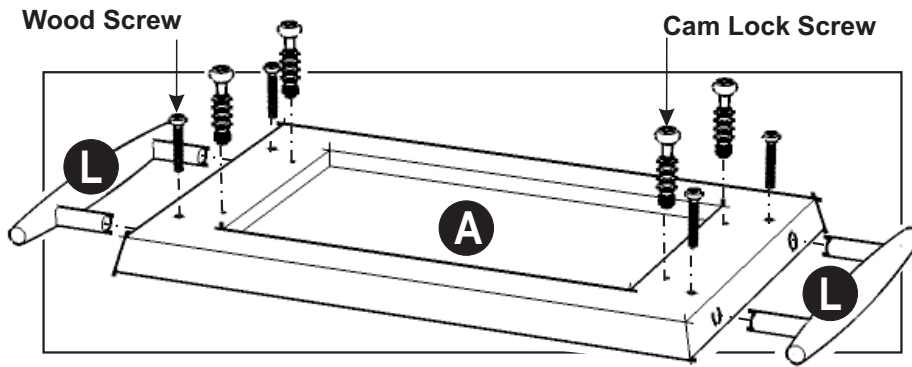

(Figure 1)

STEP 5

Turn over Top (A) upside down and place it on a soft, non-scratching surface. Attach Side Bar (L) to Top (A), using Wood Screws. Put Cam Lock Screws into the pre-drilled holes at Top (A). (See figure 1)

Place Top (A) onto the unit, using Cam Locks.

Assemble Door Pull Handles to Door (M) and (N) with Machine Screws. (See figure 2)

Attach Door (M) and (N) to the side panels, slide the door lift hinges into the side panel lift hinges. (See figure 3)

Slide Drawer (O) to into place.

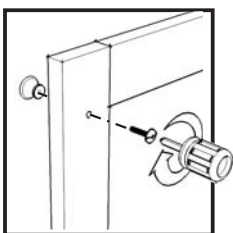
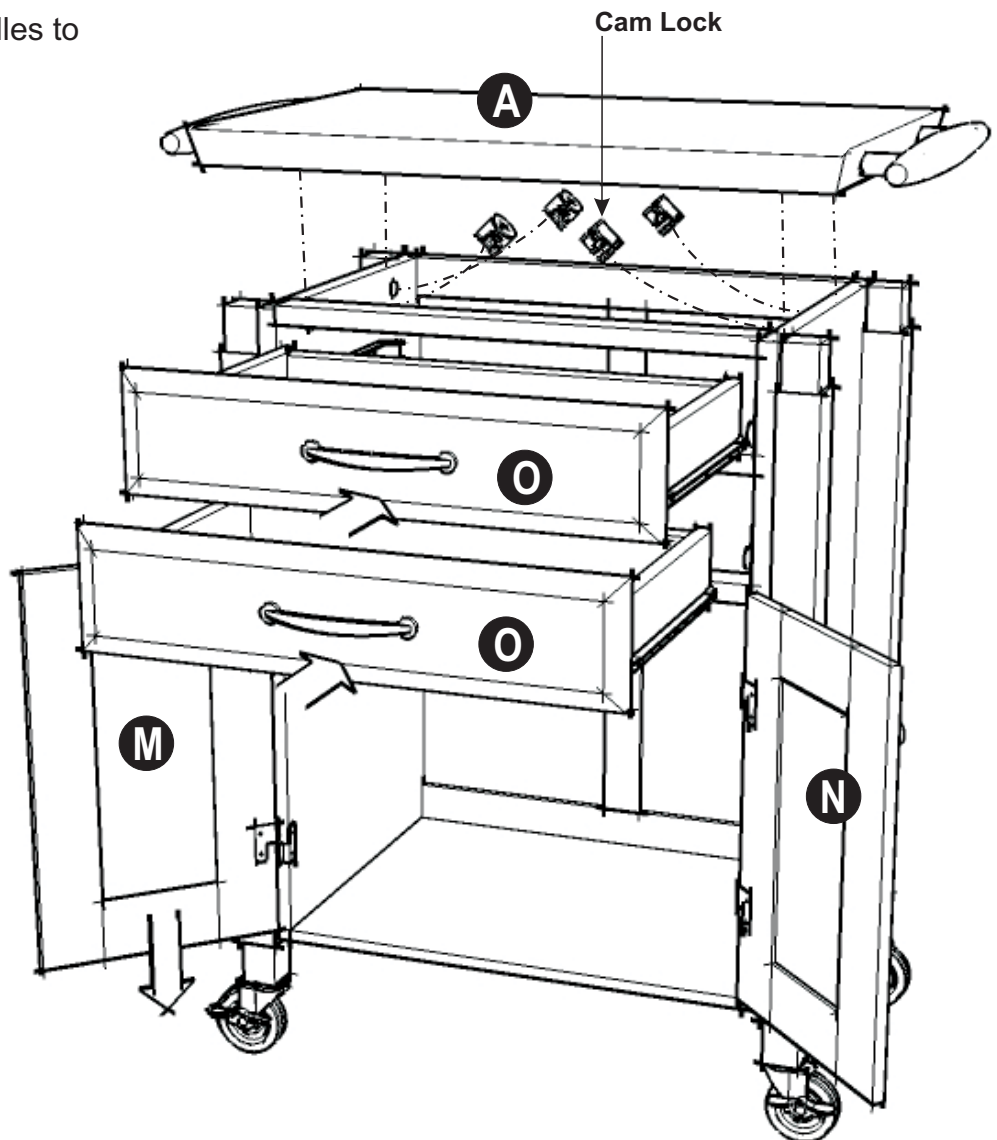

(Figure 2)

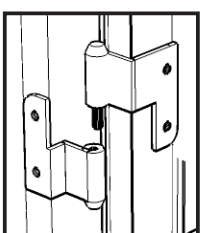

(Figure 3)

Drawer

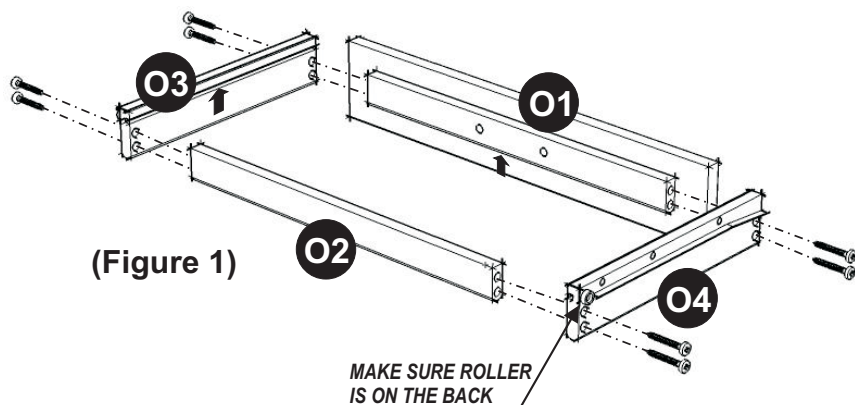

(Figure 1)

STEP 1

Attach O1 to O3 and O4, using a Phillips screwdriver and the long wood screws (4X), tighten halfway.

Attach O2 to O3 and O4 using the long wood screws (4X), tighten halfway. (See figure 1)

STEP 2

Slide O5 into the grooves in O3 and O4. Be sure to push the O5 all the way forward so it meets the O1. (See figure 2)

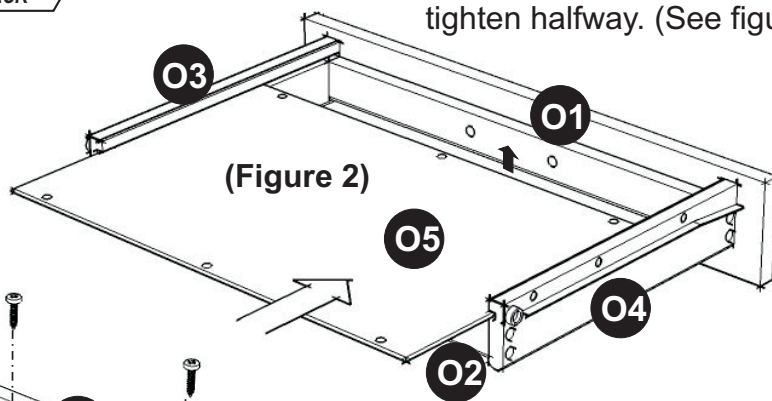

(Figure 2)

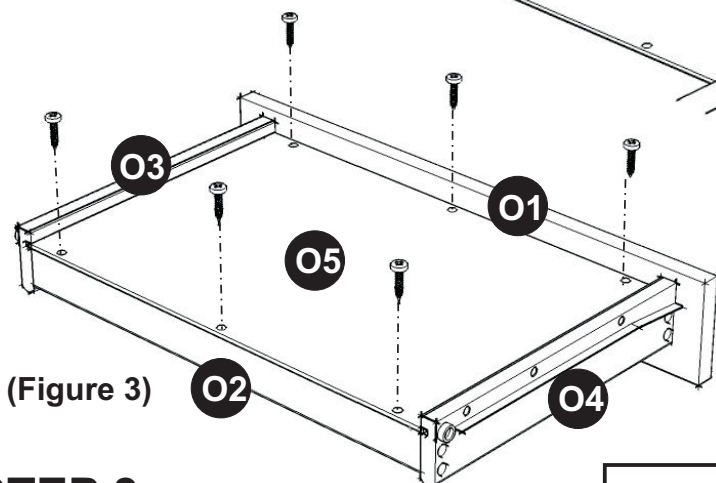

(Figure 3)

(Figure 4)

* If you are missing any of these parts, please contact our DMI Customer Service Department at 1-877-831-0319 or fax us at 1-800-755-2878.

STEP 3

Insert the short wood screws (6X) into the pre-drilled holes in O5, tighten screws. (See figure 3)

Tighten all screws used in drawer assembly.

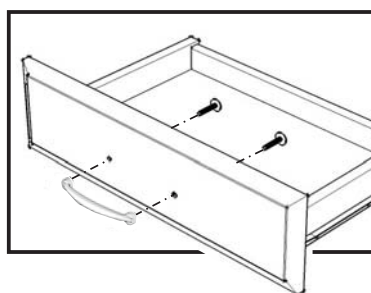

STEP 4

Attach hardware pulls with machine screws. (See figure 4)

Part List

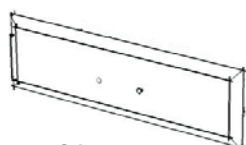

O1.
Front Part
2 pcs.

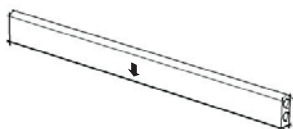

O2.
Back Part
2 pcs.

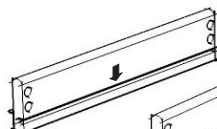

O3.
Side Part
2 pcs.

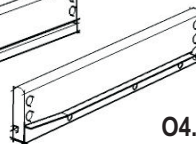

O4.
Side Part
2 pcs.



O5.
Base Part
2 pcs.