

88 5022 942 Kitchen Island

IMPORTANT NOTE

Carefully remove all the parts from the carton and put them individually on a soft cloth to prevent scratches or other damages occurring to the parts.

We have taken great care in the design of this product and request that you carefully and strictly follow our assembly instructions to ensure a completed product as it was designed.

*Home
Styles*

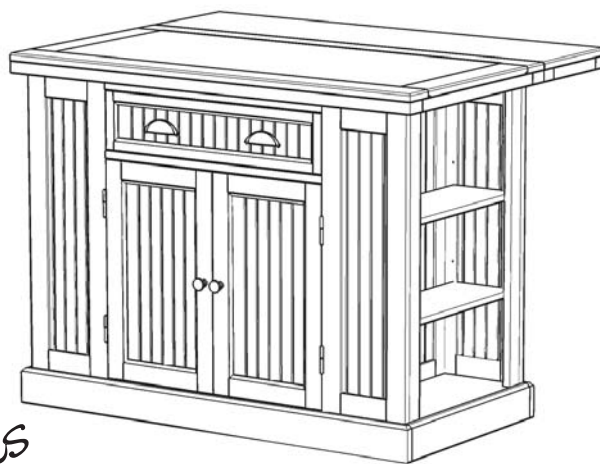

Part List

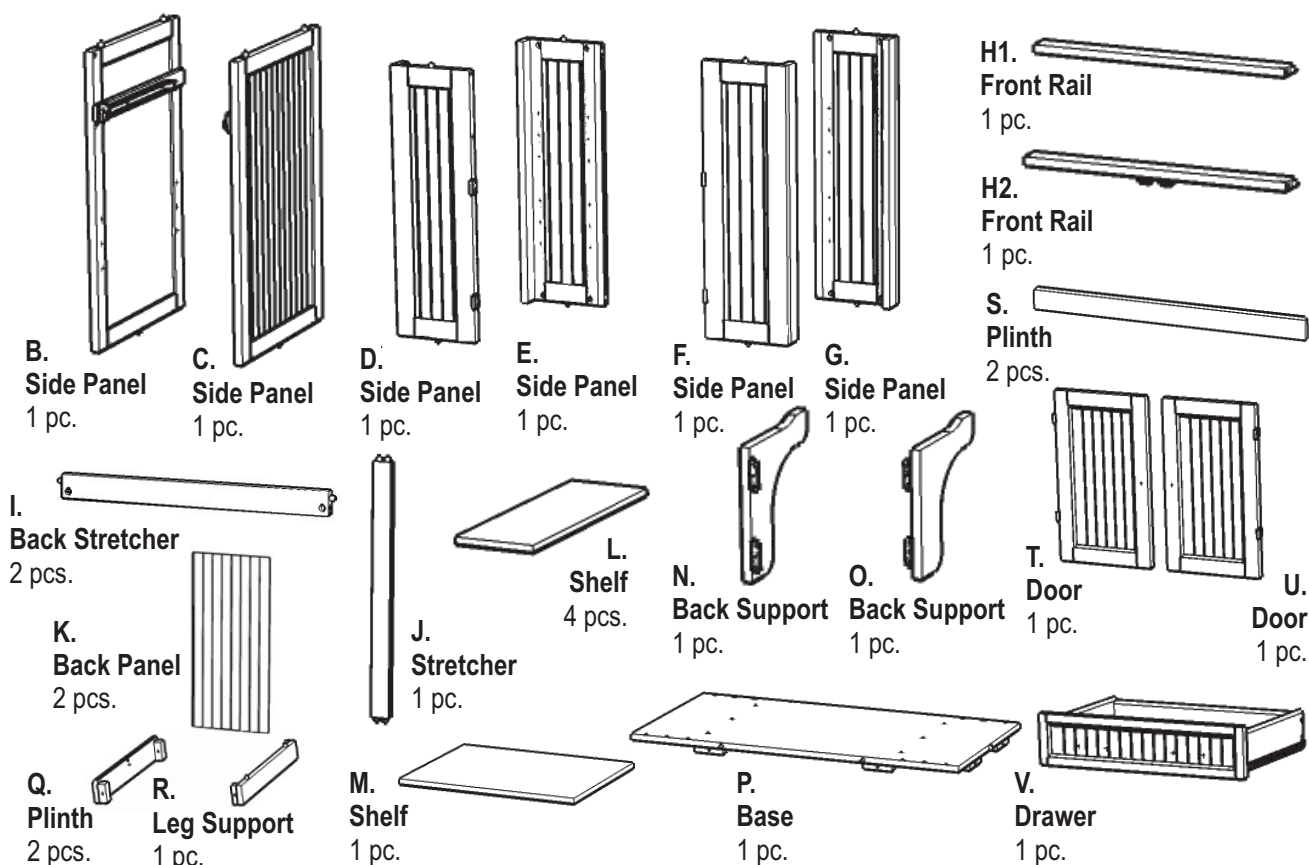

Hardware List



For assembly also need carton 88 5022 941

Tools required for assembly : **Phillips** screwdriver

Tools recommended for assembly : Level

**Home Styles Consumer Assistance : www.homestyles-furniture.com,
servicedesk@homestyles-furniture.com, 888-680-7460, 877-831-0319**

Assembly Instructions 2/6

IMPORTANT

- * Do not tighten up all the screws until each part is properly assembled.
- * You should keep Hex Wrench in a safe place as you may need to tighten up the Head Cap Bolts in the future.
- * After assembly item must be level to work properly. Use the included adjustable levelers to level.

STEP 1

Attach Top (A1) to Top (A2) with Wood Screws.

Put Cam Lock Screws into the pre-drilled holes of Top (A1), Side Panel (D), (E), (F), (G) and tighten.

Wood Screw

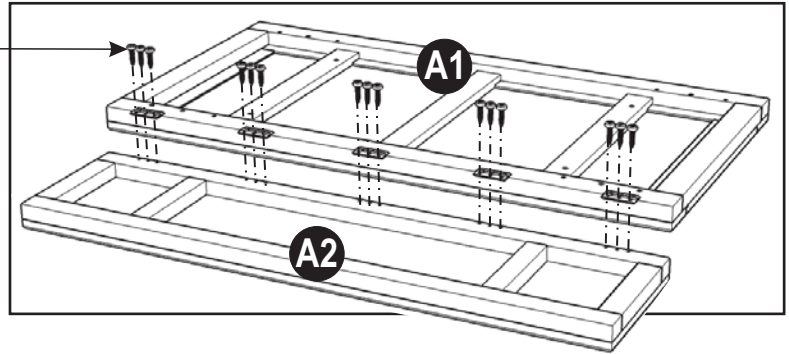

Cam Lock Screw

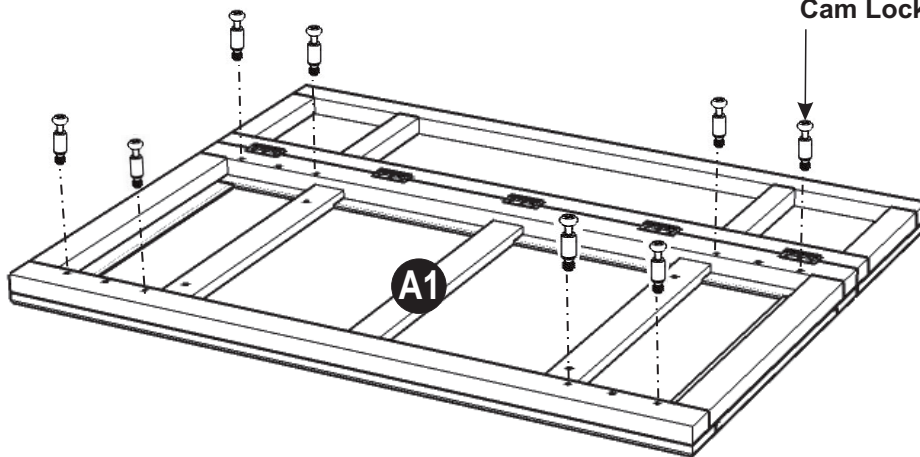

Cam Lock Screw

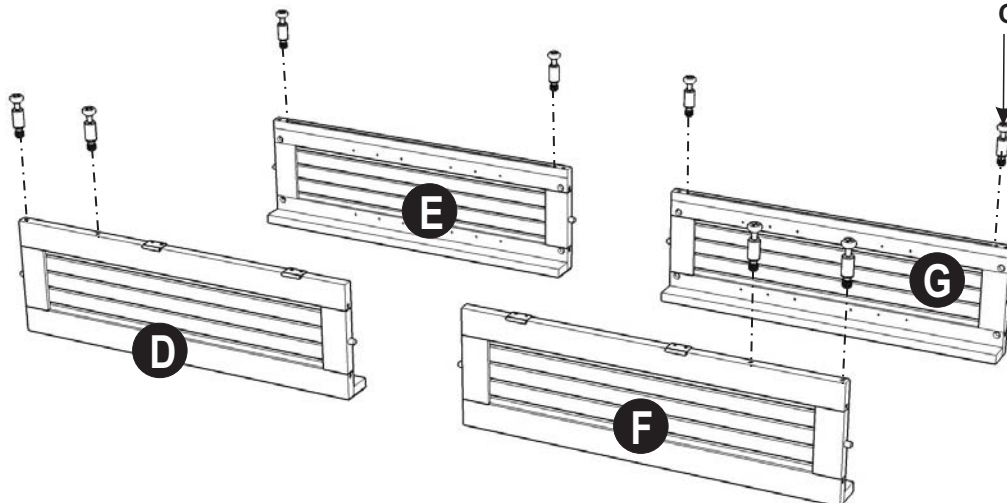

STEP 2

Attach Side Panel (B) to Base (P) with Head Cap Bolts.

Attach Side Panels (D) and (E) to Base (P) with Head Cap Bolts.

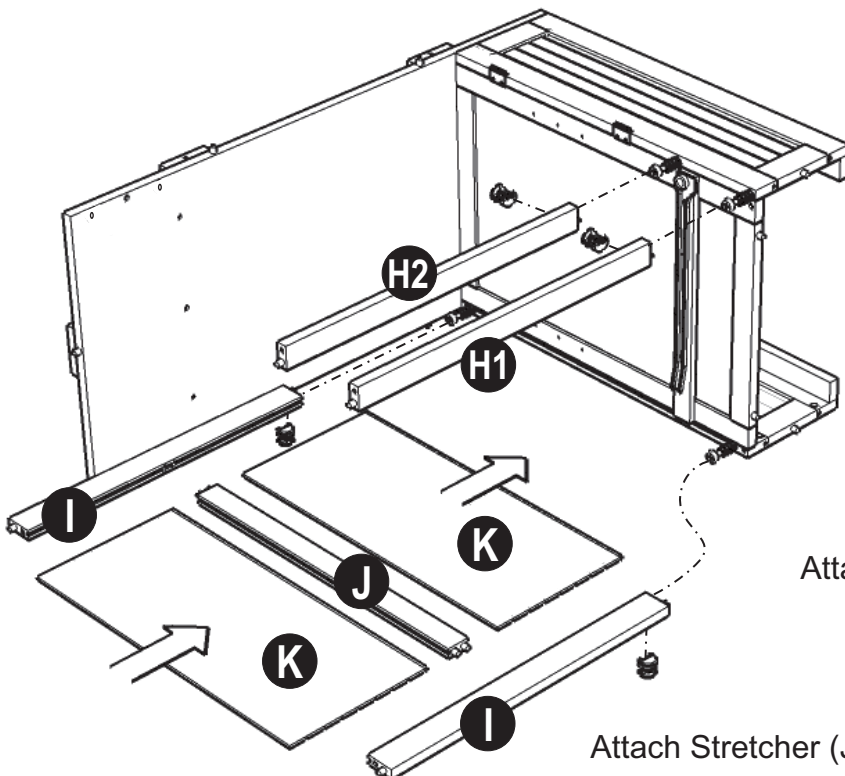
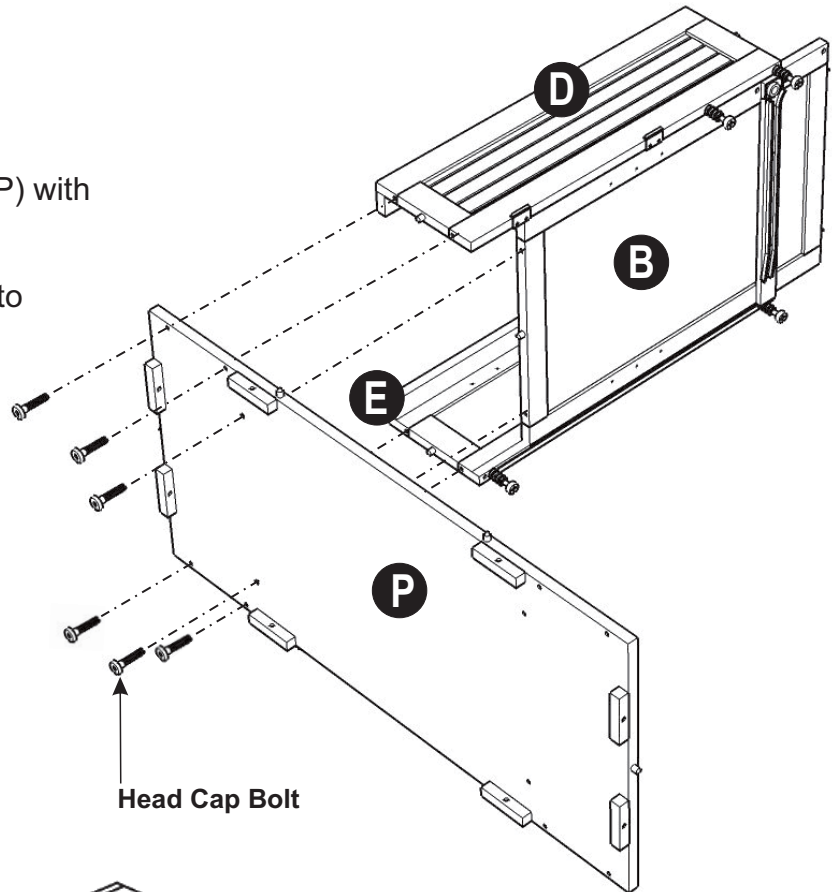

STEP 3

Attach Front Rail (H1) and Front Rail (H2) to unit using Cam Locks.

Attach Back Stretcher (I) to unit using Cam Locks.

Slide Back Panel (K) into Place.

Attach Stretcher (J) to unit then slide Back Panel (K) into place.

STEP 4

Attach Side Panel (C) to Base (P) with Head Cap Bolts.

Attach Side Panels (F) and (G) to unit with Head Cap Bolts.

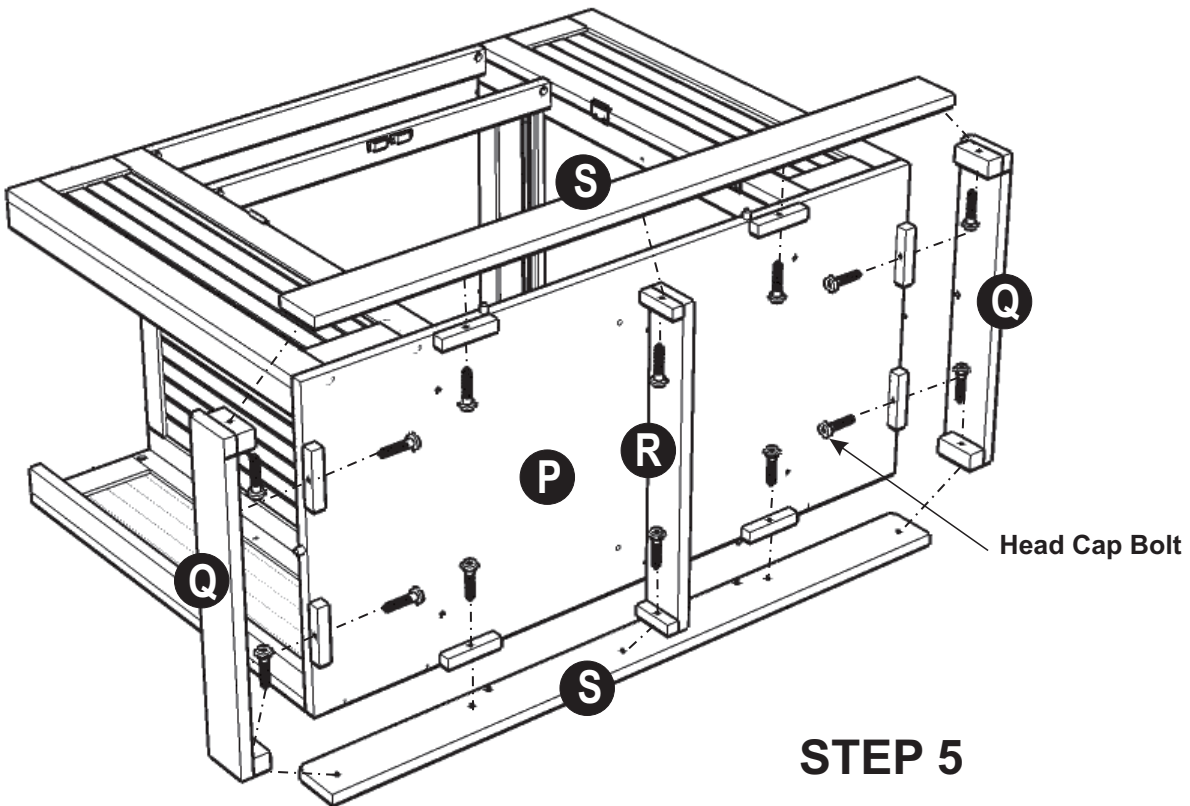
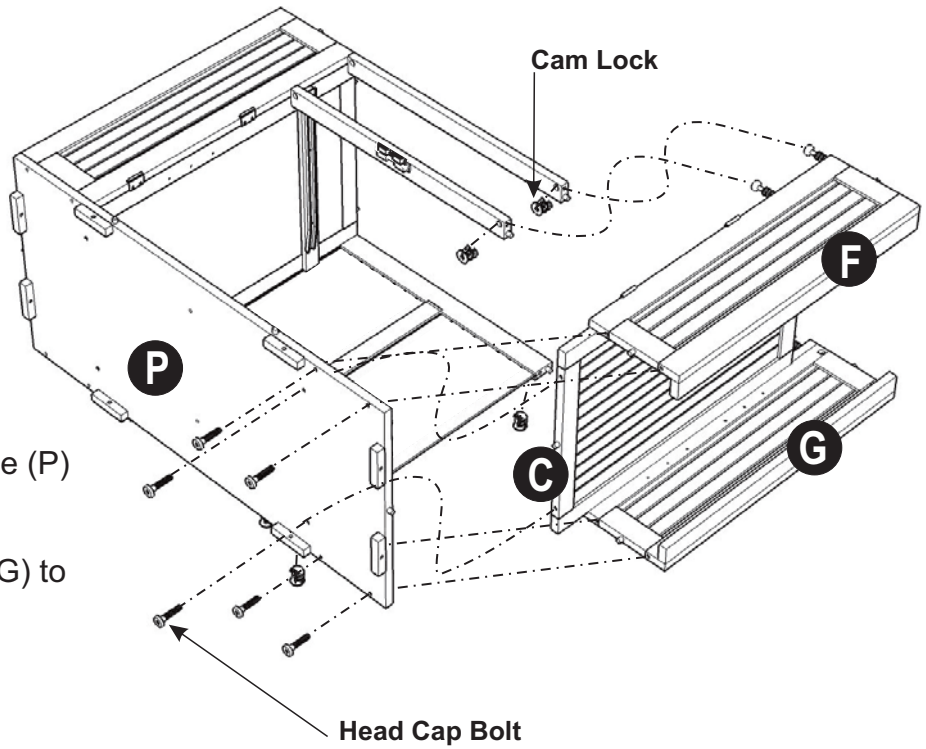

STEP 5

Attach Plinths (Q) to Base (P) with Head Cap Bolts.

Attach Plinths (S) and Leg Support (R) to unit with Head Cap Bolts.

Wood Screw

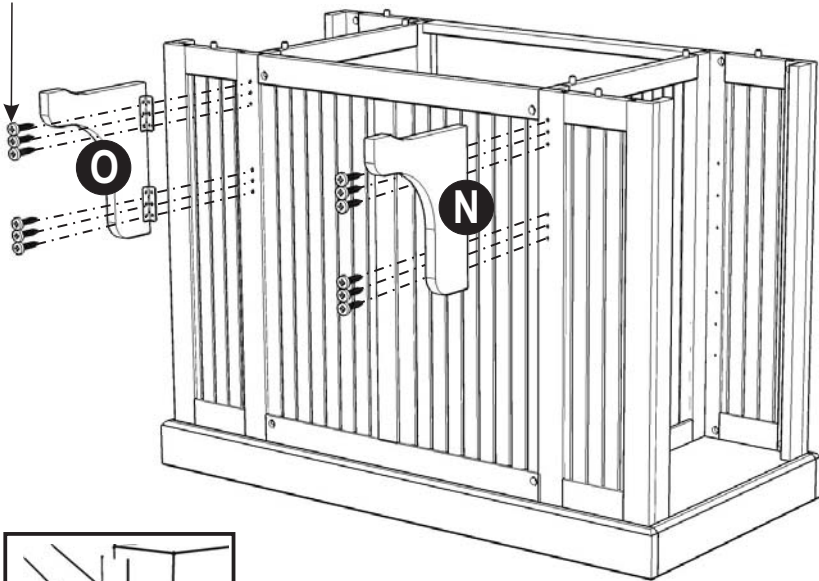

STEP 6

Attach Back Support (N) and (O) to unit with Wood Screws into pre-drilled holes.

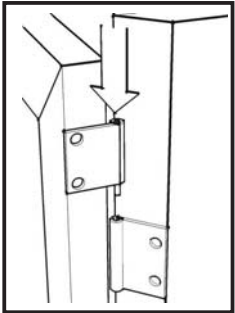

Figure 1

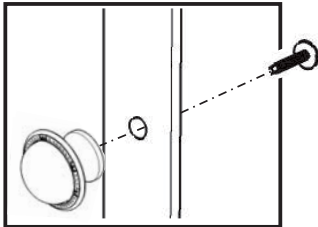
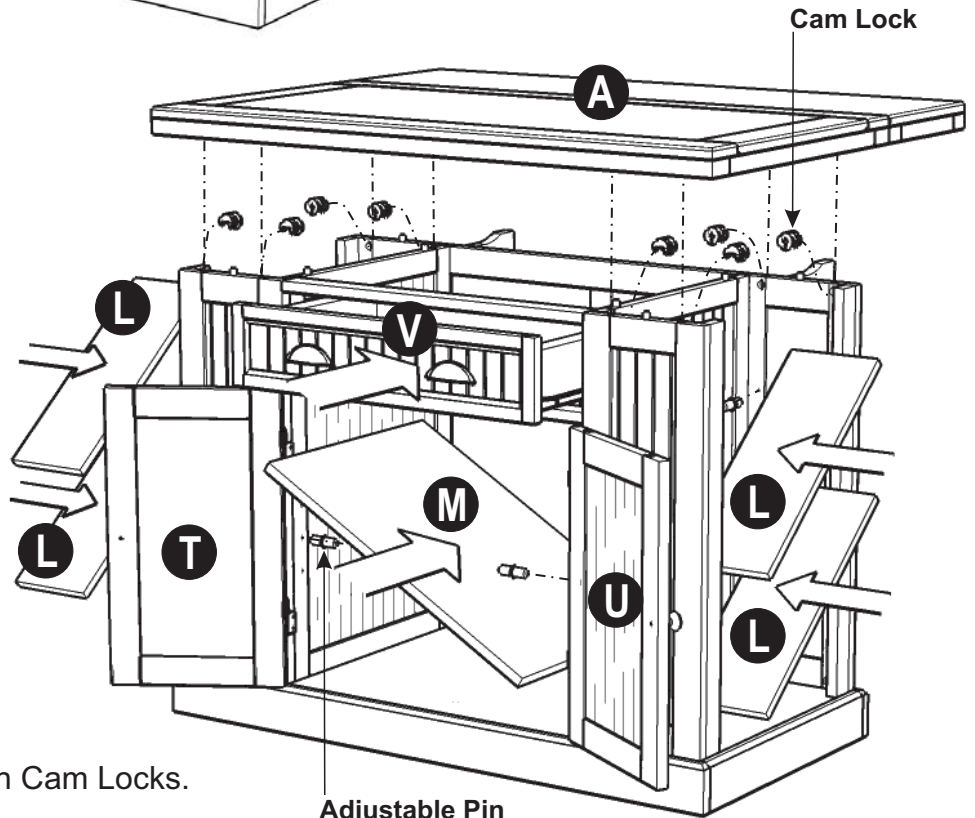

Figure 2



STEP 7

Place Top (A) onto unit with Cam Locks.

Attach Doors (T) and (U) by sliding the door lift hinges into the side panels lift hinges. (See Figure 1)

Attach Knobs to Doors (T) and (U) with Machine Screws. (See Figure 2)

Insert Adjustable Pins into side panels at the desired level, then place Shelves (L) and (M) into position.

Slide the Drawers (V) into position.

To level the unit, adjust the adjustable levelers on the bottom of unit. (See Figure 3)

Note: Unit must be level to work properly.

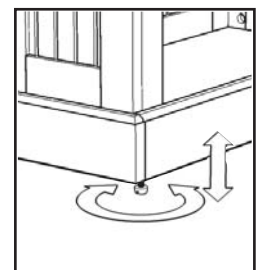

(Figure 3)

Drawer

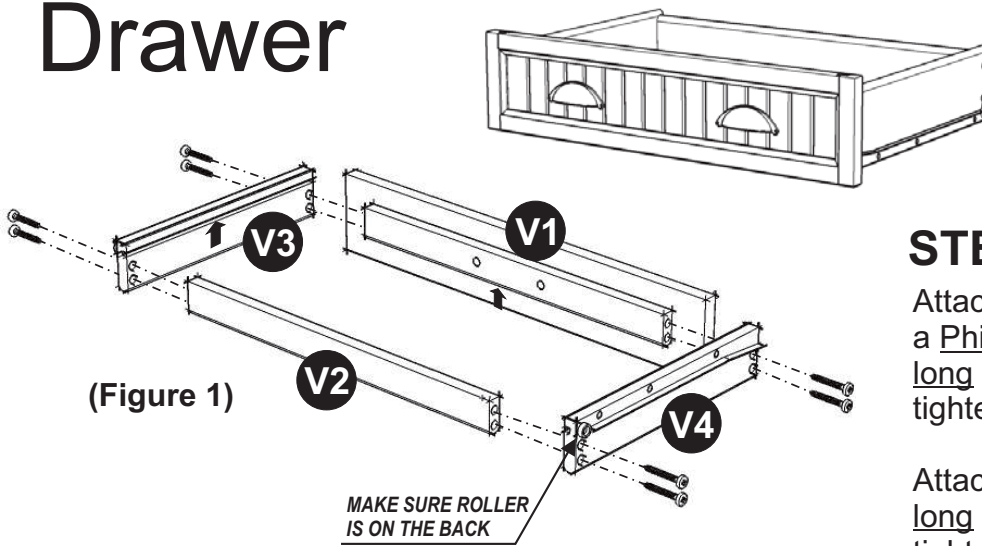

STEP 1

Attach V1 to V3 and V4, using a Phillips screwdriver and long wood screws (4X), tighten halfway.

Attach V2 to V3 and V4 using long wood screws (4X), tighten halfway. (See Figure 1)

STEP 2

Slide V5 into the grooves in V3 and V4. Be sure to push V5 all the way forward to it meets V1. (See Figure 2)

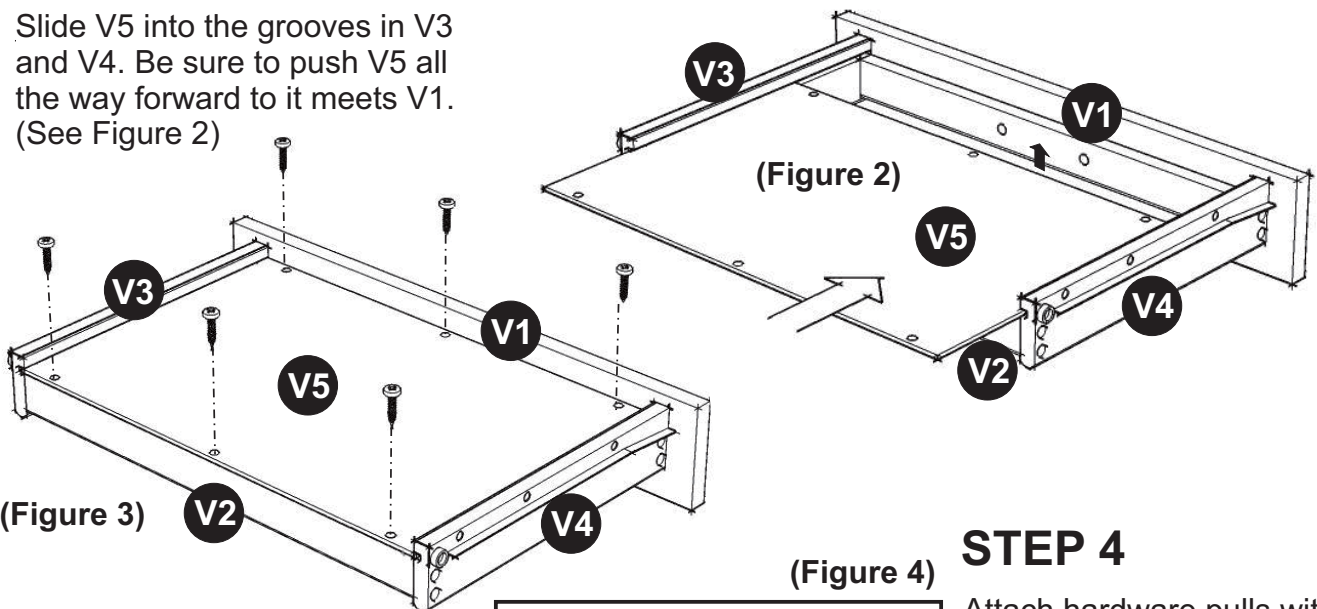

STEP 4

Attach hardware pulls with machine screws. (See Figure 4)

Tighten all screws used in drawer assembly.

STEP 3

Insert short wood screws (6X) into the pre-drilled holes in V5, tighten screws. (See Figure 3)

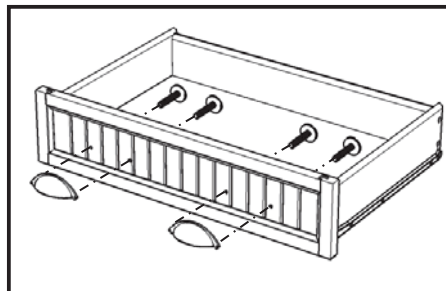

Part List



V1.
Front Part
1 pc.

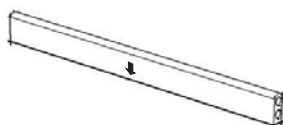

V2.
Back Part
1 pc.

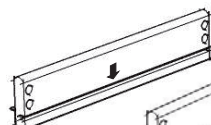

V3.
Side Part
1 pc.

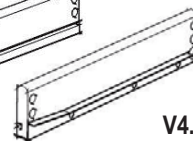

V4.
Side Part
1 pc.



V5.
Base Part
1 pc.