





Operating and Installation Instructions Freezer



To prevent accidents and machine damage, read these instructions **before** installation or use.

Contents

IMPORTANT SAFETY INSTRUCTIONS	4
Caring for the environment	13
Saving energy	14
Guide to the appliance	16
Control panel	16
Explanation of symbols	17
Switching on and off	19
Cleaning the refrigerator	19
Operating the appliance	19
Switching off for longer periods of time	20
The correct temperature	21
Temperature display	21
Setting the temperature	22
Using SuperFrost	23
Temperature and door alarm	24
Temperature alarm	24
Door alarm	25
Cancelling the door alarm	25
Selecting additional settings	26
Safety lock 	26
Audible signals 	27
Display brightness 	28
Sabbath mode 	29
Freezing and storing food	31
Maximum freezing capacity	31
What happens when you freeze fresh food?	31
Storing frozen food	31
Home freezing	32
Using accessories	35
Adjusting the interior fittings	36
Removing freezer drawers on telescopic runners	36
Removing the shelves	36
Making ice cubes	37
Ice cube maker with integrated ice cube tray	37
Turning the ice cube maker on/off	38

Making a large quantity of ice cubes	38
Changing the size of the ice cubes	39
Turning the ice cube maker on/off with the on/off button	40
Turning the ice maker off for a long time.....	40
Automatic defrosting	41
Cleaning and care	42
Cleaning agents.....	42
Rinsing the ice cube maker.....	43
Cleaning the ice cube tray.....	44
Before cleaning	46
Removing the telescopic runners.....	46
Cleaning the interior and accessories	47
Cleaning the door seal	47
Cleaning the ventilation gaps.....	47
Frequently Asked Questions	48
Causes of noises	57
Customer Service	58
Contact in the event of a fault	58
Appliance warranty and product registration	58
Information for dealers	59
Demo mode ■.....	59
Installation	61
Installation	61
Side-by-side	61
Installation location	61
Ventilation.....	62
Door panel.....	64
Before installing the appliance	64
Installation dimensions.....	66
Limiting the opening angle of the appliance door.....	67
Changing the door hinges.....	67
Building in the appliance	71
Installing the cabinet door	79
Water connection	85
Information on the fresh water connection	85
Electrical connection	87

IMPORTANT SAFETY INSTRUCTIONS

This refrigeration appliance complies with current safety requirements. Inappropriate use can, however, lead to personal injury and material damage.

Please read the operating and installation instructions carefully before using the refrigeration appliance for the first time. They contain important information on safety, installation, use, and maintenance. This is to protect yourself from injury, and from damaging your refrigeration appliance.

Miele expressly and strongly advises that you read and follow the instructions in the chapter on installing the refrigeration appliance, as well as the IMPORTANT SAFETY INSTRUCTIONS.

Miele cannot be held liable for injury or damage caused by non-compliance with these instructions.

Keep these instructions in a safe place and pass them on to any future owner.

Appropriate use

► This appliance is intended for use in the home and similar environments.

This appliance is not intended for use outdoors, in damp environments or in places exposed to rain.

► This appliance is intended exclusively for domestic use to store deep-frozen food, freeze fresh food, and make ice.

Any other usage is at the owner's risk and could be dangerous.

IMPORTANT SAFETY INSTRUCTIONS

▶ This refrigeration appliance is not suitable for storing and keeping cool medicines, blood plasma, laboratory preparations, or other similar substances or products that are subject to the Medical Device Directive. Incorrect use of the refrigeration appliance for such purposes may cause deterioration of the items stored. The refrigeration appliance is also not suitable for use in areas where there is a risk of explosion.

Miele cannot be held liable for damage resulting from incorrect or improper use or operation.

▶ This refrigeration appliance may only be used by people (including children) with reduced physical, sensory, or mental capabilities or lack of experience and knowledge if they are supervised while using it.

The refrigeration appliance may only be used by these people without supervision if they have been shown how to use it in a safe way and recognize and understand the consequences of incorrect operation.

Safety with children

▶ To reduce the risk of injury, do not allow children to play in, on or near the appliance.

▶ Ensure that any packing material is disposed of safely and kept out of the reach of children. **DANGER** of suffocation!

IMPORTANT SAFETY INSTRUCTIONS

Technical safety

▶ The coolant circuit has been checked for leaks. The refrigeration appliance complies with statutory and regulatory requirements..



▶ This refrigeration appliance contains the coolant Isobutane (R600a), a natural gas which is environmentally friendly. Although it is combustible, it does not damage the ozone layer and does not contribute to the greenhouse effect.

The use of this coolant has, however, led to a slight increase in the noise level of the appliance. In addition to the noise of the compressor, you might be able to hear the coolant flowing around the cooling circuit. Unfortunately, this cannot be avoided, but it does not affect the performance of the refrigeration appliance.

When transporting and installing the refrigeration appliance, ensure that no parts of the cooling circuit are damaged. Splashes of coolant can damage the eyes.

In the event of damage:

- Avoid open flames or anything which creates a spark.
 - Disconnect the refrigeration appliance from the power supply.
 - Ventilate the room where the refrigeration appliance is located for several minutes.
 - Contact Miele Customer Service.
- ▶ The more coolant there is in a refrigeration appliance, the larger the room it should be installed in. In the event of a leakage, if the appliance is in a small room, there is the danger of a combustible gas/air mixture building up. For every 11 g of coolant, at least 1 m³ of room space is required. The amount of coolant in the refrigeration appliance is stated on the data plate inside the appliance.

IMPORTANT SAFETY INSTRUCTIONS

- ▶ To avoid the risk of damage to the appliance, make sure that the connection data (fuse rating, frequency and voltage) on the data plate corresponds to the household supply. Check that this is the case before connecting the appliance. Consult a qualified electrician if in any doubt.
- ▶ The electrical safety of the appliance can only be guaranteed when correctly grounded. It is essential that this standard safety requirement is met. If in any doubt please have the electrical installation tested by a qualified electrician.
- ▶ Reliable and safe operation of this appliance can only be assured if it has been connected to the electricity supply.
- ▶ If the power cord is damaged, it must be replaced by a Miele authorized technician in order to protect the user from harm.
- ▶ Do not connect the appliance to the electrical supply with a power bar or extension cord. These are a fire hazard and do not guarantee the required safety of the appliance.
- ▶ If moisture gets into electrical components or into the power cord, it could cause a short circuit. Therefore, do not operate the machine in areas where there may be moisture or splashing water (e.g., garages, laundry rooms).
- ▶ This appliance must not be installed and operated in mobile installations (e.g. on a ship).
- ▶ Do not use a damaged appliance. It could be dangerous. Check the appliance for visible signs of damage.
- ▶ For safety reasons, this appliance may only be used after it has been built in.
- ▶ During installation, side-by-side heater installation, maintenance and repair work, the appliance must be disconnected from the electrical power supply. It is only completely isolated from the electricity supply when:
 - the circuit breaker has been tripped, or

IMPORTANT SAFETY INSTRUCTIONS

- the screw-type fuses on the electrical service panel have been removed or
 - the power cord has been unplugged. Pull on the plug and not on the cord when removing it from the outlet.
- ▶ Installation, repair, and maintenance work should only be performed by a Miele-authorized service technician. Work by unqualified persons could be dangerous and may void the warranty.
- ▶ Any manufacturer's warranty will be void if the appliance is not repaired by a Miele approved service technician.
- ▶ Defective components should only be replaced by Miele original parts. Only with these parts can the manufacturer guarantee the safety of the appliance.

IMPORTANT SAFETY INSTRUCTIONS

Correct use

- ▶ The appliance is designed for use within a certain climate range (ambient temperatures), and should not be used outside this range. The climate range for your appliance is stated on the data plate inside the appliance. Installing it in a room with too low an ambient temperature, e.g. a garage, will lead to the appliance switching off for longer periods so that it cannot maintain the required temperature.
- ▶ **WARNING! DANGER of overheating!** Do not cover or block the air vents. This can impair the efficiency of the appliance, increase the power consumption and cause damage to the appliance.
- ▶ If storing food which contains a lot of fat or oil in the appliance, make sure that it does not come into contact with plastic components as this could cause stress cracks or break the plastic.
- ▶ Risk of fire and explosion. Do not store any explosive materials or products containing flammable propellants (e.g., spray cans) in the appliance. Electrical components can cause flammable mixes of gases to ignite.
- ▶ Risk of explosion. Do not operate any electrical equipment (e.g., an electric ice-cream maker) inside the refrigeration appliance. Risk of sparking and explosion.
- ▶ Do not store cans or bottles containing carbonated drinks or liquids which could freeze in the freezer section. The cans or bottles could burst, causing injury or damage.
- ▶ Risk of injury. Never handle frozen food or the metal parts of the appliance with wet hands. Your hands may freeze to the frozen food or to the metal.
- ▶ Risk of injury. Do not take ice cubes out with your bare hands and never place ice cubes or ice pops in your mouth straight from the freezer section. The very low temperature of the frozen food can cause frost burn to the lips and tongue.

IMPORTANT SAFETY INSTRUCTIONS

- ▶ Do not refreeze partially or fully defrosted food. Consume defrosted food as soon as possible, as it will lose its nutritional value and spoil if left for too long. Defrosted food may only be refrozen after it has been cooked.
- ▶ When eating stored food, there is a danger of food poisoning. Storage times will depend on several factors, including the freshness and quality of the food, as well as the temperature at which it is stored. Observe the manufacturer's "use-by" dates and storage instructions.
- ▶ Use only genuine original Miele parts. If parts or accessories from other manufacturers are used, the warranty may become invalid.

Cleaning and maintenance

- ▶ Do not use any oil or grease on the door seals. They can cause the seals to deteriorate over time.
- ▶ Never use a steam cleaner to clean the appliance. The steam can reach the electrical components and cause a short circuit.
- ▶ Sharp edged or pointed objects will damage the evaporator, causing irreversible damage to the appliance. Do not use sharp edged or pointed objects to
 - remove frost or ice,
 - separate frozen foods or remove ice trays.
- ▶ Never place electric heaters or candles in the appliance to defrost it. These can damage the plastic parts.
- ▶ Do not use defrosting sprays or de-icers, as they could contain substances which could damage the plastic parts or which might cause the build-up of gases and pose a danger to health.

IMPORTANT SAFETY INSTRUCTIONS

Transport

- ▶ To avoid damage to the appliance, always transport it upright and in its packaging.
- ▶ Risk of injury and damage. The refrigeration appliance is very heavy and must be transported by 2 people.

Disposal of your old appliance

- ▶ Children could become trapped in the machine and could suffocate.
 - Remove the machine doors.
 - Remove the drawers.
 - Leave the adjustable shelves in the machine so children cannot climb inside.
- ▶ DANGER of electric shock!
 - Cut the plug off the power cord.
 - Cut the power cord off the old appliance.
- ▶ Dispose of them separately from the appliance.
- ▶ Ensure that the appliance is not stored in the vicinity of gasoline or inflammable gases and liquids during and after disposal.
- ▶ Make sure that the coolant pipework is not damaged during disposal to avoid uncontrolled leakage of oil and coolant (see data plate for coolant type).
- ▶ Splashes of coolant can cause damage to the eyes. Be careful not to damage any part of the pipework while awaiting disposal, e.g. by
 - puncturing the coolant channels in the evaporator,
 - kinking any pipework,
 - scratching the surface coating.

IMPORTANT SAFETY INSTRUCTIONS

Symbol on the compressor (depending on model)

This information is only relevant for recycling. There is no risk during normal operation.



- ▶ The oil in the compressor can be fatal if swallowed or if it penetrates the airways.

Disposal of packaging material

The packaging is designed to protect the appliance from damage during transportation. The packaging materials used are selected from materials which are environmentally friendly for disposal and should be recycled.

Ensure that any plastic wrappings, bags, etc. are disposed of safely and kept out of the reach of children. Return the packaging to your dealer.

Disposing of your old appliance

Electronic and electrical appliances contain many valuable materials. They also contain certain materials, compounds, and components which were essential for their correct functioning and safety. These could be hazardous to your health and to the environment if disposed of with general waste or if handled incorrectly. Please do not, therefore, dispose of your old appliance with general waste.

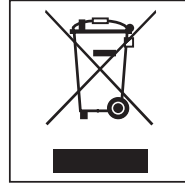

Instead, please make use of officially designated collection and disposal points to dispose of and recycle electrical and electronic appliances. By law, you are solely responsible for deleting any personal data from the appliance prior to disposal.

Take care not to damage your refrigeration appliance's pipework before or during transportation to an authorized collection depot.

This is to ensure that coolant in the cooling circuit and oil in the compressor is contained, and will not leak into the environment.

Please ensure that your old appliance poses no risk to children while being stored for disposal. For additional information, see "IMPORTANT SAFETY INSTRUCTIONS" in these operating and installation instructions.

Saving energy

	Normal energy consumption	Increased energy consumption
Installation / Maintenance	In a well-ventilated room.	In an enclosed, poorly ventilated room.
	Protected from direct sunlight.	In direct sunlight.
	Away from heat sources (radiator, range/oven).	Near a heat source (radiator, oven).
	Where the ideal room temperature is approx. 68°F (20°C).	Where the ambient room temperature is above 77°F (25°C).
	Air vents uncovered and dusted regularly.	Where the ventilation openings are blocked and full of dust.
Temperature setting	0°F (-18°C) in the freezer	The lower the temperature set for the freezer, the higher the energy consumption.

Saving energy

	Normal energy consumption	Increased energy consumption
Use	Drawers and shelves arranged as they were when the appliance was delivered.	
	Only open the door when necessary and for as short a time as possible. Store food in an organized way.	Frequent opening of the door for long periods will cause a loss of coldness. The appliance will try to cool down and the compressor will run for longer periods.
	When shopping, use a cooler bag and place the food in the appliance as soon as possible. Allow hot food and drinks to cool down before placing them in the appliance.	Hot food or food at room temperature raises the temperature inside the appliance. The appliance will try to cool down and the compressor will run for longer periods.
	Store food well packaged.	The evaporation or condensation of liquids in the Freezer Zone will cause a loss of coldness.
	Do not overfill the appliance in order to allow the air to circulate.	Poor air circulation will cause a loss of coldness.





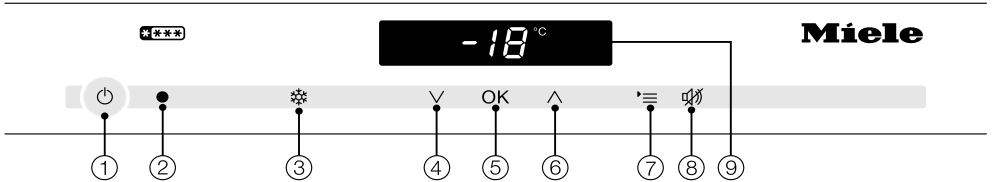



Guide to the appliance

Control panel



- ① On/Off button for the whole appliance
- ② Optical interface (for Miele Technical Service only)
- ③ For turning the SuperFrost function on and off
- ④ For setting the temperature (∇ for colder); selection button in settings mode
- ⑤ For confirming your selection (OK button)
- ⑥ For setting the temperature (^ for warmer); selection button in settings mode
- ⑦ For selecting and deselecting settings mode
- ⑧ For switching the temperature and door alarm off
- ⑨ Display with temperature and symbols (symbols only visible in settings mode, in the event of an alarm/message; see table for explanation of symbols)

Explanation of symbols

Symbol	Meaning	Function
	Safety lock	Prevents the user from unintentionally turning off the appliance, adjusting the temperature, turning on the SuperFrost function or entering settings.
	Audible signals	Selection options for the button tone and the door and temperature alarm tone
	Miele@home (if available)	Only visible when the Miele@home communication module or communication stick is used (see “Miele@home”)
	Display Brightness Settings	For adjusting the brightness of the display
	Sabbath Mode	For turning Sabbath mode on and off
	Power supply	Confirms that the appliance is connected to the electricity supply when it is not switched on, flashes when there is a power outage
	Alarm (only visible when the door or temperature alarm sounds)	Lights up when there is a door alarm; flashes when there is a temperature alarm, power outage or other fault
	Demo mode (only visible when Demo mode is active)	For turning off Demo mode

Guide to the appliance

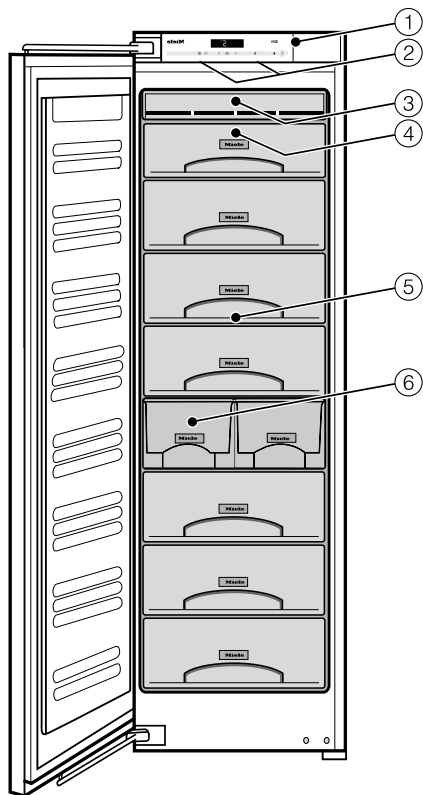

This drawing is for illustration purposes only.

- ① Control panel
- ② Interior lighting
- ③ NoFrost unit
- ④ Top freezer drawer, can also be used as a freezing tray
- ⑤ Freezer drawers (number depends on model)
- ⑥ Ice cube drawer with automatic ice maker

Before first use

Packaging material

- Remove all packaging material from the inside of the appliance.

Removing the protective film

- Carefully remove the protective film.

Cleaning the refrigerator

Please refer to the relevant instructions in “Cleaning and care”.

- Clean the inside of the appliance and the accessories.
- Clean the ice cube maker: after selecting the “Rinse ice cube maker ” setting; the ice cube maker and the water supply pipework are rinsed automatically with water.

Operating the appliance

A light touch of the finger on the sensors is all that is required to operate this appliance.

A tone will sound each time a sensor is touched. You can deactivate this if you wish (see “Selecting additional settings – Acoustic signals”).

Switching on the appliance

To enable the internal temperature to get sufficiently cold, allow the appliance to run for a few hours before placing food inside it.

Once the appliance is connected to the electricity supply, the power supply symbol  will soon appear in the display.



- Touch the On/Off button.

The appliance will start cooling. The power connection symbol  goes out and the temperature appears in the display.

The temperature display and the alarm symbol  will flash at the same time until the required temperature is reached. If the current temperature is above 32°F (0°C), two bars will flash in the display.

When the appliance door is opened, the interior lighting comes on and the LED lighting becomes brighter until it reaches its maximum brightness.

Switching on and off

Switching off the appliance



- Touch the On/Off button.
If this does not work, the safety lock is activated.

The temperature shown in the display will go out and the power connection symbol  appears.

The cooling process is now turned off.

Switching off for longer periods of time

If, during a long absence, the refrigeration appliance is switched off but not cleaned and the door(s) left shut, there is a danger of bacteria building up inside the appliance.

It is essential to clean the refrigeration appliance.

If the refrigeration appliance is not going to be used for a longer period of time, observe the following:

- Turn the appliance off.
- Unplug the appliance or trip the circuit breaker.
- Empty the ice cube drawer.

 Risk of damage to the ice cube maker.

If the water supply is cut off while the ice cube maker is still in use, the water intake pipe can freeze up.

Turn the ice cube maker off if the water supply is interrupted (e.g., while on vacation).

- Close the water supply faucet.
- Clean the refrigeration appliance and leave the door ajar to air the appliance and avoid odors building up inside.

The correct temperature

It is very important to set the correct temperature for storing food in the appliance. Bacteria will cause food which is not stored at the correct temperature to deteriorate rapidly. Temperature influences the growth rate of these bacteria. Reducing the temperature reduces their growth rate.

To freeze fresh food and to store frozen food for a long time, a temperature of **0°F (-18°C)** is required. At this temperature the growth of bacteria is generally halted. As soon as the temperature rises above 14°F (-10°C), the bacteria become active in the food again so it cannot be kept as long. For this reason, partially defrosted or defrosted food must not be re-frozen. Food may be re-frozen once it has been cooked, as the high temperatures achieved when cooking destroy most bacteria.

The temperature in the appliance will rise:

- the more often the door is opened and the longer it is kept open,
- the more food that is stored in it,
- the warmer the food is which is being put into it,
- and the higher the ambient temperature surrounding it. The appliance is designed for use within specific ambient temperatures (climate range). Do not use in ambient temperatures for which it is not designed.

Temperature display

In normal operation, the temperature display shows the **average, current temperature in the freezer zone**.

If the temperature is not within the normal temperature display range, dashes will flash in the display instead of the temperature.

Depending on the ambient temperature and the temperature setting, it can take the appliance a few hours to reach the temperature required and for this temperature to then be shown as a constant temperature in the display.

 If the temperature in the freezer remains above 0°F (-18°C) for a long time, check that the frozen food has not started to defrost.

If it has, check that the food is safe to use and if it is, then use it as soon as possible or cook it before freezing it again.

The correct temperature

Setting the temperature

- Use the two sensors below the display to set the temperature.

When you touch the sensor



- The temperature decreases.



- The temperature increases.

The temperature value flashes while the temperature is being set.

The following information appears in the display when the sensors are touched:

- With the first touch: The **last temperature set** flashes.
- Each subsequent touch: The temperature changes in 1°F increments.
- Keeping your finger on the sensor changes the temperature continuously.

Approximately 5 seconds after the last time a sensor was touched, the **actual** temperature inside the appliance will automatically be displayed.

Or

- Touch the OK button to confirm your selection.

If you have adjusted the temperature, **wait for approximately 6 hours if the appliance is not very full and for approximately 24 hours if the appliance is full** before checking the temperature display. It will take this long for an accurate reading to be given.

- If the temperature is still too high or too low at the end of this time, adjust it again.

Temperature range

The temperature can be adjusted from 5°F to -18°F (-15°C to -28°C).

SuperFrost function

For best results, turn on the SuperFrost function before putting fresh food into the freezer.

Fresh food will be frozen quickly, so that the nutritional value, vitamin content, appearance, and taste are maintained.

Exceptions:

- Placing food in the freezer that is already frozen.
- Only freezing up to 4.4 lbs (2 kg) of fresh food daily.

Turning on SuperFrost

The SuperFrost function should be turned on **6 hours before placing food in the freezer**. When freezing the **maximum amount of food**, the SuperFrost function should be switched on **24 hours beforehand**.



- Touch the SuperFrost button; it will light up in yellow.

The appliance will work at full power to lower the temperature in the freezer zone.

Turning off SuperFrost

The SuperFrost function turns off automatically after approx. 65 hours. The exact amount of time will vary according to how much fresh food is placed in the freezer. The SuperFrost ❄ symbol will go out and the appliance will run at normal power again.

To save energy, you can manually switch off the SuperFrost function once the freezer zone reaches a **constant** temperature of 0°F (-18°C) or colder. Monitor the temperature inside the freezer.



- Touch the SuperFrost button; the yellow light will go out.

The appliance will then continue running at normal power.

Temperature and door alarm

The appliance has been fitted with a warning system which ensures that the temperature in the freezer cannot rise unnoticed and to avoid energy being wasted if the door is left open.

Temperature alarm

 If the temperature in the freezer remains above 0°F (-18°C) for a long time, check that the frozen food has not started to defrost.

If it has, check that the food is safe to use and if it is, then use it as soon as possible or cook it before freezing it again.

If the freezer temperature becomes too warm, the alarm symbol  for the freezer flashes in the display and an alarm will also sound.

The temperature the appliance is set at determines the temperature the appliance recognizes as being too warm.

The acoustic and visual signals are triggered, for example:

- when the appliance is switched on and the temperature in the appliance differs significantly from the set temperature,
- if a lot of warm room air enters the freezer when food is being loaded, rearranged, or taken out,
- when freezing large amounts of food at once,
- when freezing fresh food which is still warm,
- after a power outage,
- if the appliance has a fault.

The alarm will stop sounding and the alarm symbol  will go out as soon as the temperature has dropped to the correct level again.

Cancelling the temperature alarm

If the alarm is disturbing you, it can be switched off.



- Touch the button to turn off the temperature alarm.

The alarm will stop.

The alarm symbol  will remain on until the set temperature has been reached.

Door alarm

An alarm will sound if the door is left open for too long. The alarm symbol  will light up.

The amount of time until the door alarm is triggered depends on the setting selected and can be either 2 minutes (factory default) or 4 minutes. However, the door alarm can also be turned off (see “Selecting additional settings – Acoustic signals”).

As soon as the door is closed, the alarm stops sounding and the alarm symbol  disappears from the display.

If no alarm sounds even though there is a door alarm, the alarm has been turned off in settings mode (see “Selecting additional settings – Acoustic signals”).

Cancelling the door alarm

If the alarm is disturbing you, it can be switched off.



- Touch the sensor to turn off the door alarm.

The alarm will stop.





The alarm symbol  will continue to be displayed until the door is closed.

Selecting additional settings

Certain settings for the appliance can only be selected in settings mode.

While you are in settings mode, the door alarm and any other fault messages are suppressed automatically, but the alarm symbol  lights up on the display.

Available settings

	Activate and deactivate the safety lock
	Turn the ice maker on/off (set the amount of water; rinse the ice maker; set the cleaning position for the ice cube tray)
	Switch acoustic signals on/off
	Change the brightness of the display
	Switch Sabbath mode on/off

All available settings for the **ice maker** are described in “Making ice cubes” and “Cleaning and maintenance”.

All other available settings are described below.

Safety lock

The safety lock can be activated to prevent:

- the appliance being switched off by mistake,
- the temperature being changed by mistake,
- selection of the SuperFrost function,
- settings being adjusted by mistake (it is only possible to deactivate the safety lock).

This prevents the appliance being switched off or settings adjusted without your knowledge; for example, by children.

Activating and deactivating the safety lock



- Touch the settings sensor.

All symbols available for selection will appear in the display and the  symbol flashes.



- Touch the OK sensor to confirm your selection.

The last selected setting flashes and the  symbol lights up in the display.

Selecting additional settings



- By touching the \wedge or \vee sensor, you can now select whether the safety lock is activated or deactivated:
□: the safety lock is deactivated
⌚: the safety lock is activated.



- Touch the OK sensor to confirm your selection.

The selected setting will be adopted and the  symbol will flash.



- Touch the settings sensor to leave the settings mode. Otherwise the appliance will exit the settings mode automatically after approximately one minute.

The  symbol will appear in the display when the safety lock is activated.

Audible signals

The appliance has audible signals such as the button tone and the door and temperature alarms.

You can turn the button tone and the door alarm on and off, but you cannot turn off the temperature alarm.

There are 4 settings to choose from. Option 3 is set at the factory; this means that the button tone and the door alarm are switched on.

Switching acoustic signals on/off



- Touch the settings sensor.

All symbols available for selection will appear on the display and the  symbol will flash.



- Touch the sensors for setting the temperature (\wedge or \vee) repeatedly until the  symbol flashes on the display.



- Touch the OK sensor to confirm the selection.

The most recently selected setting flashes and the  symbol lights up on the display.

Selecting additional settings



- Now touch the \wedge or \vee sensors to select:

\emptyset : keypad tone off; door alarm off

1 : keypad tone off; door alarm on (after 4 minutes)

2 : keypad tone off; door alarm on (after 2 minutes)

3 : keypad tone on; door alarm on (after 2 minutes)



- Touch the OK sensor to confirm the selection.

The selected setting is applied; the ♪ symbol flashes.



- Touch the settings sensor to exit settings mode.

If you do not do this, the appliance electronics will exit settings mode automatically after approximately 1 minute.

Display brightness

You can adjust the brightness of the display to suit the ambient light conditions in the room.

The display brightness can be adjusted incrementally from 1 to 3 . The factory default setting is 3 (maximum brightness).

Changing the brightness of the display



- Touch the settings sensor.

All symbols available for selection will appear in the display and the  symbol flashes.



- Touch the sensors for setting the temperature (\wedge or \vee) repeatedly until the  symbol flashes in the display.



- Touch the OK sensor to confirm your selection.

The last selected setting flashes and the  symbol lights up in the display.

Selecting additional settings



- By touching the \wedge or \vee sensor, you can now alter the brightness of the display:
1 : Dimmest setting
2 : Medium setting
3 : Brightest setting.



- Touch the OK sensor to confirm your selection.

The selected setting will be adopted and the \odot symbol will flash.



- Touch the settings sensor to leave the settings mode. Otherwise the appliance will exit the settings mode automatically after approximately one minute.

Sabbath mode

The appliance offers a Sabbath mode for the purposes of religious observance.

The following are switched off:

- the interior lighting when the appliance door is opened,
- all acoustic and visual signals,
- the temperature display,
- SuperFrost (if previously selected).

The following can be selected:

- the settings button for turning off Sabbath mode
- and the On/Off button.

The Sabbath mode function will turn itself off automatically after approximately 120 hours.

Ensure that the appliance door is properly closed, as visual and acoustic alarms are switched off.

Danger of food poisoning!

Any power outage during Sabbath mode will not be shown on the display. After a power outage, the appliance will restart in Sabbath mode. When power is restored, no notification of the power outage will appear on the display.

If there is a power outage during Sabbath mode, check the quality of the food. Do not consume any defrosted food.

Selecting additional settings

Turning on Sabbath mode



- Touch the Settings sensor.

All symbols available for selection will appear in the display and the  symbol flashes.



- Touch the sensors for setting the temperature (\wedge or \vee) repeatedly until the  symbol flashes in the display.



- Touch the OK sensor to confirm your selection.

The last selected setting flashes and the  symbol lights up in the display.



- By touching the \wedge or \vee sensor you can now switch on Sabbath mode. To do this, select the 7 setting.



- Touch the OK sensor to confirm your selection.

The selected setting is applied, the  symbol lights up.

As soon as the  symbol goes out in the display after 3 seconds, Sabbath mode is switched on.

- Turn off Sabbath mode after the Sabbath has passed.

Turning off Sabbath mode



- Touch the Settings sensor to leave Sabbath mode.

The temperature will appear in the display and the interior lighting will come on.

Freezing and storing food

Always observe USDA food safety guidelines.

 Risk of fire from electrical appliances.

Operating electrical devices in the appliance can cause sparks to form. Do not operate any electrical devices inside the appliance.

reabsorb it during the defrosting process, and very little water collects around the defrosted food.

Storing frozen food

Never re-freeze partially or fully defrosted food. Defrosted food must only be re-frozen after it has been cooked.

When buying frozen food to store in your freezer, make sure to check:

- that the packaging is not damaged
- the expiration date
- the temperature at which the frozen food is being stored in the store

The length of time food can be kept is reduced if it has been stored at a temperature warmer than 0°F (-18°C).

- Buy frozen food at the very end of your shopping trip.
- Store it in the freezer compartment as soon as possible.

Maximum freezing capacity

To ensure that fresh food placed in the freezer freezes through to the core as quickly as possible, the maximum freezing capacity must not be exceeded. The maximum freezing capacity for freezing within a 24-hour period is given on the data plate: "Freezing capacitylbs/24 hrs."

What happens when you freeze fresh food?

Fresh food should be frozen as quickly as possible so that the nutritional value of the food, its vitamin content, appearance and flavor are maintained.

Food which takes a long time to freeze will lose more water from its cells, which then shrink. During the defrosting process, only some of this water is re-absorbed by the cells. What this means in practice is that the food loses more moisture. You can see this in the large amount of water that collects around the food when it defrosts.

If food is frozen quickly, the cells have less time to lose moisture, so they shrink less. As there is not so much moisture loss, it is easier for the food to

Freezing and storing food

Home freezing

Only freeze food that is fresh and in good condition.

Tips for home freezing

- The following types of food are **suitable for home freezing**: fresh meat, poultry, game, fish, vegetables, herbs, fresh fruit, dairy products, baked goods, leftovers, egg yolks, egg whites, and a range of pre-cooked meals.
- The following types of food **are not suitable for freezing**: lettuce, radishes, sour cream, mayonnaise, whole eggs in their shells, onions, whole raw apples and pears.
- To retain color, taste, aroma, and vitamin C, vegetables should be blanched before they are frozen. To do so, place them portion by portion into boiling water for 2–3 minutes. Then, remove and plunge the vegetables into ice-cold water to cool quickly. Leave the vegetables to drain.
- Lean meat freezes better than fatty meat and can be stored for considerably longer.
- Separate chops, steaks, cutlets, etc. with a sheet of plastic freezer film. to prevent them from freezing together in a block.
- Do not season raw food or blanched vegetables with herbs or salt before freezing. Cooked food should only be lightly seasoned. The flavor of some herbs intensifies when frozen.

- Placing hot food or drink in the freezer causes food that is already frozen to partially thaw and increases energy consumption. Allow hot food and drink to cool down before placing it in the freezer.

Packaging food for freezing

- Freeze food in portions.
 - **Suitable packaging**
 - Plastic films
 - Freezer bags
 - Aluminum foil
 - Freezer containers
 - **Unsuitable packaging**
 - Packing paper
 - Parchment paper
 - Cellophane
 - Garbage bags
 - Plastic shopping bags
 - Remove as much air as possible from the packaging before sealing.
 - Close the packaging tightly with
 - rubber bands,
 - bag clips,
 - string or bag ties, or
 - freezer tape.
- Tip:** Freezer bags and poly tubing may also be sealed using home heat sealing kits.
- Label the packaging with the contents and the date of freezing.

Before placing food in the freezer

- When freezing more than 4.4 lb (2 kg) of fresh food, switch on the Super-Frost function some time before placing the food in the freezer (see “SuperFrost”).

This helps food which is already stored in the freezer to stay frozen.

Placing food in the freezer zone

 The following maximum loading weights must not be exceeded:

- Top freezer drawer = 11 lb (5 kg)
- Freezer drawer = 55 lb (25 kg)
- Glass shelf = 77 lb (35 kg)

Unfrozen food should not touch frozen food, as this will cause the frozen food to begin to thaw.

- When placing items in the freezer zone, ensure that the packaging and containers are dry to prevent them from freezing together or to the walls.

- Freezing small amounts of food

Place the food in the lower freezer drawers.

- Place the food flat in the bottom of the freezer drawer so that it freezes through to the middle as quickly as possible.

When placing food on the glass shelf make sure that you do not block the ventilation slits in the back wall of the appliance. They are important for ensuring trouble-free operation and normal energy consumption.

- Freezing the maximum amount (see data plate)

- Remove the freezer drawers.
- Place the food flat on the glass shelves so that it freezes through to the middle as quickly as possible.

Once the food has frozen:

- Place the frozen food in the freezer drawer and push it back in.

- Large items

If you wish to freeze large items, such as turkey or game, you can remove the glass shelves between the freezer drawers.

- Remove the freezer drawers. Remove the glass shelves by lifting them slightly and pulling them forward and out.

Freezing and storing food

Storage time for frozen food

The storage life of food is very variable, even at a constant temperature of 0°F (-18°C). Decomposition processes also take place in frozen food, albeit at a very reduced speed. Fat can become rancid from contact with oxygen in the air, for example. This is why lean meat can be stored approx. twice as long as fatty meat.

The storage times quoted are guide values for the storage life of different food groups in the Freezer Zone.

Food group	Storage time (Months)
Ice cream	2 to 6
Bread, baked goods	2 to 6
Cheese	2 to 4
Fish, oily	1 to 2
Fish, lean	1 to 5
Sausage, ham	1 to 3
Game, pork	1 to 12
Poultry, beef	2 to 10
Vegetables, fruit	6 to 18
Herbs	6 to 10

Where the storage time given on the packaging differs, follow the advice on the packaging.

Defrosting frozen goods

Never re-freeze partially or fully defrosted food. Defrosted food may only be re-frozen after it has been cooked.

Frozen food can be defrosted in different ways:

- In a microwave
- In an oven using “Convection” or the “Defrost” setting
- At room temperature
- In the Fridge Zone (the cold given off by the frozen food helps to keep the other food cold)
- In a steam oven

Flat pieces of partially thawed meat or fish can be placed directly into a hot skillet.

Meat and poultry (e.g., hamburgers, chicken, fish) should not come into contact with other foods while defrosting. Catch the defrosting liquid and dispose of it carefully.

Fruit can be thawed at room temperature, either in the packaging or in a covered bowl.

Most vegetables can be cooked while still frozen. Just put straight into boiling water or hot grease. The cooking time is slightly less than that of fresh vegetables due to changes in the cell structure.

Freezing and storing food

Cooling drinks quickly

 Risk of injury from broken glass! Bottles and cans of drinks, particularly carbonated drinks, can burst when frozen. Do not freeze any drinks in bottles or cans.

Using accessories

 **WARNING! DANGER** of injury and damage!
Do not use any mechanical or other types of aids which are not recommended by the manufacturer to accelerate the defrosting process.

Using the cool pack

The cool pack prevents the temperature in the freezer zone from rising too quickly in the event of a power outage. This can help prolong the storage life.

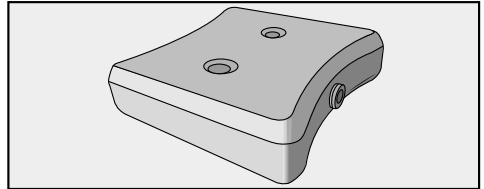

- Place the cool pack in the top drawer of the freezer zone.

The cool pack will be at its most effective after it has been in the freezer for approx. 24 hours.

– In the event of a power outage

- Place the frozen cool pack directly on top of the frozen food in the front of the top drawer.

Tip: When placing fresh food in the freezer, use the cool pack to separate the fresh food from the food which is already frozen so that the frozen food does not begin to thaw.

Tip: The cool pack can also be used to keep food or drink cool for a short period of time in a cool box or bag.

Adjusting the interior fittings

Removing freezer drawers on telescopic runners

Some of the freezer drawers are on telescopic runners and can be removed for filling, emptying, or cleaning purposes.

- Pull the drawers out as far as they will go.

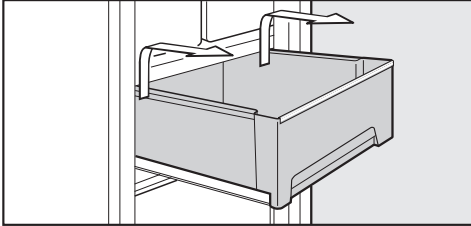

- Holding the sides of the drawer at the back, lift it up and then forward and out.

Push the runners back in again to avoid damaging them.

Be careful not to wash away the special lubricant in the telescopic runners during cleaning.
Wipe the telescopic runners with a damp cloth to clean them.

- To replace the drawer, push the runners back in completely and then place the drawer on them.
- Push the drawer into the appliance until it clicks into position.

Removing the shelves

The shelves can be removed.

- Lift the shelf slightly at the front and then pull it forward and out.

Making ice cubes

For the automatic ice maker to operate, it must be connected to a water supply (see “Water supply”).

Danger to health!

Rinse out the ice maker and water supply line:

- before using for the first time,
- if the ice maker has not been used for a long time,
- regularly when in continuous use (at least once a month) to remove residual ice from the system (to avoid blocking the water supply line) and
- before switching the ice maker off for a long time. See “Cleaning and care – Rinsing the ice maker” for details of how to enable this function.

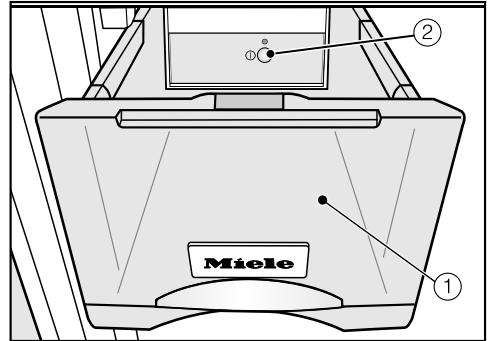

The ice cube drawer ① contains an automatic ice cube maker ②.

When the ice cube maker is switched on, the indicator light on it lights up.

Ice cubes can only be made when the ice cube drawer is completely closed.

Ice cube maker with integrated ice cube tray

Only make normal domestic quantities of ice cubes with the ice cube maker.

After the initial commissioning of the machine, it can take up to 24 hours for the first ice cubes to drop out of the ice cube maker and collect in the drawer.

After the ice cube maker has been turned off and on again, it can take up to 6 hours for this process to be completed.

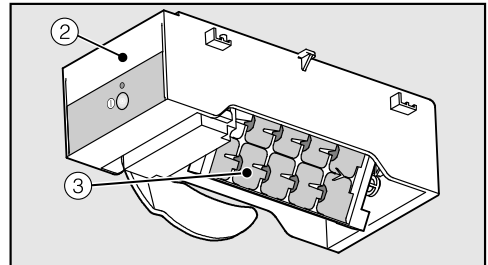

An ice cube tray ③ where ice cubes are produced is integrated into the ice cube maker ②.

The ice cube tray automatically empties into the drawer as soon as the ice cubes are ready. The ice cube maker automatically stops making ice cubes when the ice cube drawer is full. The drawer will not fill up to the top edge.

Making ice cubes

The ice cube maker can be turned off independently of the freezer if you do not want to make any ice cubes.

If the ice cube maker is turned off, the ice cube drawer can be used as an extra drawer for freezing fresh food and storing frozen food.

Turning the ice cube maker on/off

Check that the ice cube drawer is empty before turning the ice cube maker on.



- Touch the settings sensor button.

All symbols available for selection will appear on the display and the  symbol will flash.

- Touch the sensor button for setting the temperature (∇ or ▲) repeatedly until the symbol for the ice cube maker  flashes on the display.
- Touch the OK sensor button to confirm the selection.
- Touch the ∇ and ▲ sensor buttons to make the settings for the ice cube maker:
 - ∇: Ice cube maker is turned off
 - ▲: Ice cube maker is turned on
- Touch the OK sensor button to confirm the selection.

The selected setting is saved.

- Touch the settings sensor button to exit Settings mode or

- close the appliance door.

The electronics will otherwise switch to normal operation after approx. one minute.

Making a large quantity of ice cubes

The amount of ice cubes made by the machine depends on the temperature in the Freezer Zone. The lower the temperature, the more ice cubes are produced within a given time. At a temperature of 0°F (-18°C), approx. 2 lb (1 kg) of ice cubes will be produced within 24 hours.

Tip: If you require a large quantity of ice cubes, replace the full ice cube drawer with the drawer to the right of it.

The ice cube maker will start making ice cubes again as soon as this drawer is closed.

Changing the size of the ice cubes

The size of the ice cubes depends on the quantity of water being taken in. You are able to set this quantity according to your wishes. To make larger ice cubes, increase the amount of water being taken in by the ice cube maker. The amount of water is set to medium (E3) at the factory.

Setting the water quantity

This setting can only be selected if the ice cube maker is on.



- Touch the settings button.

All symbols available for selection will appear on the display and the  symbol will flash.

- Touch the buttons for setting the temperature (∨ or ∧) repeatedly until the symbol for the ice cube maker  flashes on the display.

- Touch the OK button to confirm your selection.

- By touching the ∨ and ∧ buttons, you can now select the water quantity settings:

0: the ice cube maker is off

1: the ice cube maker is on

2: **set the water quantity**

3: select the ice cube tray cleaning position

4: rinse the ice cube maker

- Touch the OK button to confirm your selection.

- By touching the ∨ or ∧ button, you can now set the water volume you require (E1 to E8):

E1: low

E8: high

- Touch the OK button to confirm your selection.

The selected setting will be saved.

- Touch the settings button to exit settings mode or

- close the appliance door.



The electronics will otherwise switch to normal operation after approx. one minute.

Making ice cubes

Turning the ice cube maker on/off with the on/off button

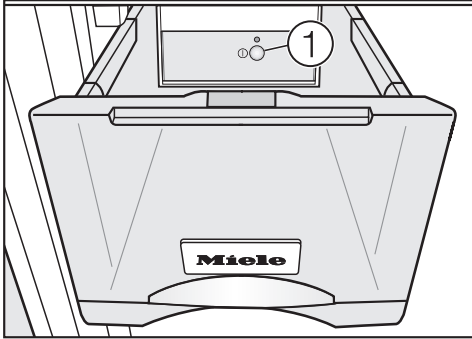
- Open the ice cube drawer slightly.



- Press the on/off button ① on the ice cube maker
 - until the indicator light comes on. The symbol for the ice cube maker  will appear on the display. The ice cube maker is now on.
 - until the indicator light goes out. The symbol for the ice cube maker  will disappear from the display. The ice cube maker is now off.
- Close the ice cube drawer.

Turning the ice maker off for a long time.

 Risk of damage!

If the water supply is cut off while the ice maker is still in use, the water intake pipe can freeze up.

Turn the ice maker off if the water supply is interrupted (e.g., while on vacation).

- Close the faucet in the water supply line.

If  begins to flash in the display, it means that there is still some water remaining in the ice maker.

- Leave the ice maker turned on for another day so that the remaining ice cubes can be produced.
- Turn the ice maker off as soon as the remaining ice cubes have been produced.
- Take the remaining ice cubes out of the ice cube container and dispose of them.

The appliance is equipped with a “NoFrost” system. The freezer defrosts automatically.

The moisture generated in the appliance collects on the condenser and is automatically defrosted and evaporates periodically.

This automatic defrosting system enables the Freezer Zone to remain permanently ice-free. However, the food stored in the freezer will not defrost.

Cleaning and care

 **WARNING! DANGER** of electric shock!

Unplug the appliance or trip the circuit breaker.

 **WARNING! Fire hazard!**

Do not damage the coolant pipework.

 Do not let water get into the electronic unit.

 Steam from a steam cleaning appliance could reach the electrical components and cause a short circuit.

Do not use a steam cleaner.

The data plate located inside the appliance must not be removed. It contains information which is required in the event of a service call.

Cleaning agents

Cleaning and conditioning agents used inside the appliance must be food safe.

To avoid damaging the surfaces of your appliance, **do not** use

- cleaning products containing soda, ammonia, acid, or chloride,
- lime scale removers,
- abrasive cleaning products, such as scouring powder, scouring liquid, or pumice stones,
- cleaners containing solvents,
- stainless steel cleaners,
- dishwasher detergent,
- oven sprays,
- glass cleaning agents,
- hard, abrasive sponges and brushes, such as pot scrubbers,
- eraser sponges,
- sharp metal scrapers.

We recommend using a clean sponge, lukewarm water with a little liquid dish soap to clean the surfaces of the appliance.

The following pages contain important information on cleaning.

Rinsing the ice cube maker

 Risk to health due to contaminated water.

Bacteria can develop in water which has been sitting in the water supply lines for several days. This poses a risk to your health.

Rinse out the ice cube maker and water supply line:

- before using for the first time,
- if the ice cube maker has not been used for a long time (more than 5 days),
- regularly when in continuous use (at least once a month) to remove residual ice from the system (to avoid blocking the water supply line),
- before switching the ice cube maker off for a long time.

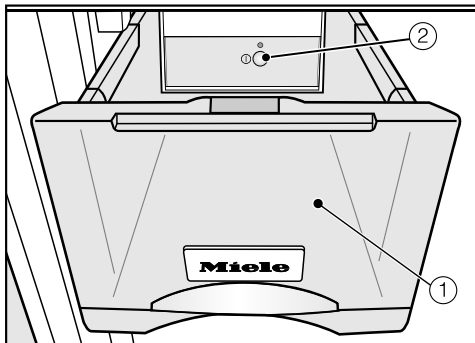

After selecting the “Rinse the ice cube maker” setting, the ice cube maker  and the water supply pipework will be rinsed automatically with water.

The ice cube tray then moves to the cleaning position so that it can be dried by hand.

The water collects in the ice cube drawer .

Check that the ice cube drawer is empty before selecting “Rinse the ice cube maker”. Otherwise, the water will empty onto the contents of the drawer.

“Rinse the ice cube maker” can only be selected when the ice cube maker is on.



- Touch the settings button.

All symbols available for selection will appear on the display and the  symbol will flash.

- Touch the buttons for setting the temperature (∇ and \wedge) repeatedly until the symbol for the ice cube maker  flashes on the display.

- Touch the OK button to confirm your selection.

- By touching the ∇ and \wedge buttons, you can now select the setting you want:

: The ice cube maker is switched off

: The ice cube maker is switched on

: Set the water volume

: Select the ice cube tray cleaning position

: **Rinse the ice cube maker**

- Touch the OK button to confirm your selection.

The selected setting is saved. The ice cube maker symbol  in the display and the indicator light on the ice cube maker will flash while the ice cube maker is being rinsed.

Cleaning and care

You will hear the ice cube tray turning to a slanted position.

- Wait until the ice cube tray has stopped moving before continuing.

The ice cube maker will then switch off.

- Carefully remove the ice cube drawer, which is now full of water. Empty and clean it.

The ice cube tray **cannot be removed** and must be cleaned in situ.

- Dry the ice cube tray ② with a cloth.

As soon as the ice cube maker is switched on, the ice cube tray rotates back to its original position.

Cleaning the ice cube tray

Clean the ice cube tray:

- Before switching off the ice cube maker for a long period of time
- Regularly, to remove ice and water residues.

If you have already selected the setting “Rinse the ice cube maker” (see “Rinsing the ice cube maker”), the ice cube tray will already be in the cleaning position.

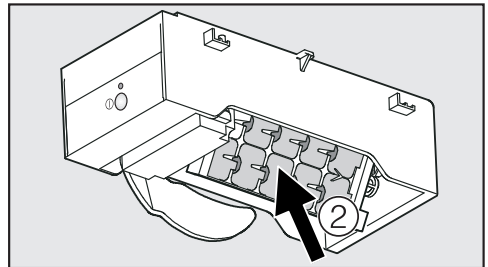

The ice cube tray ② **cannot be removed** and must be cleaned in situ. For this reason the ice cube tray must be set to the cleaning position.

Setting the cleaning position

This setting can only be selected if the ice cube maker is on.

- Empty the ice cube drawer.



- Touch the settings button.

All symbols available for selection will appear on the display and the  symbol will flash.

- Touch the buttons for setting the temperature (∇ and \wedge) repeatedly until the symbol for the ice cube maker  flashes on the display.

- Touch the OK button to confirm your selection.

- By touching the ∇ and \wedge buttons, you can now select the setting you want:

0: The ice cube maker is switched off

1: The ice cube maker is switched on

2: Set the water volume

3: **Select the ice cube tray cleaning position**

4: Rinse the ice cube maker

- Touch the OK button to confirm your selection.

The selected setting is saved and you will hear the ice cube tray moving into a slanted position.

- Wait until the ice cube tray has stopped moving before continuing.

The ice cube maker will then switch off. The symbol for the ice cube maker  will disappear from the display.

- Remove the ice cube drawer.

The ice cube tray cannot be removed and must be cleaned in place.

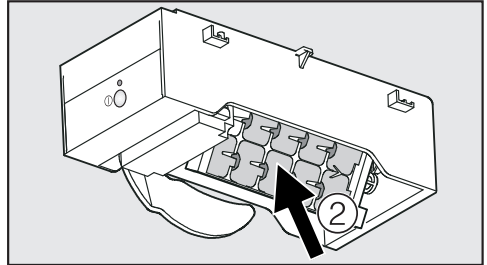

- Clean the ice cube tray  and the ice cube drawer with lukewarm water and liquid dish soap. Wipe thoroughly with clean water and dry with a cloth.

As soon as the ice cube maker is switched on, the ice cube tray rotates back to its original position.

Cleaning and care

Before cleaning

- Turn the appliance off.

The display goes out and the cooling function is turned off.

If this does not work, the safety lock is activated (see “Selecting additional settings – Activating and deactivating the safety lock”).

- Unplug the appliance or flick the circuit breaker to off.
- Take any food out of the appliance and store it in a cool place.
- Remove the shelves:
Lift them up at the front slightly and then pull them forward and out.

The telescopic runners on the shelves are **not** dishwasher safe.

Removing the telescopic runners

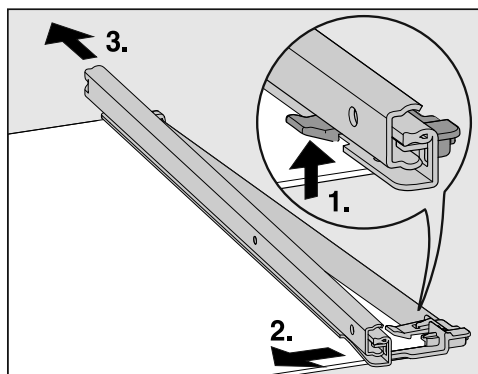

- To remove the telescopic runners:
 1. Push the catch upward.
 2. Push the telescopic runner to the side.
 3. Then pull the telescopic runner off to the rear.

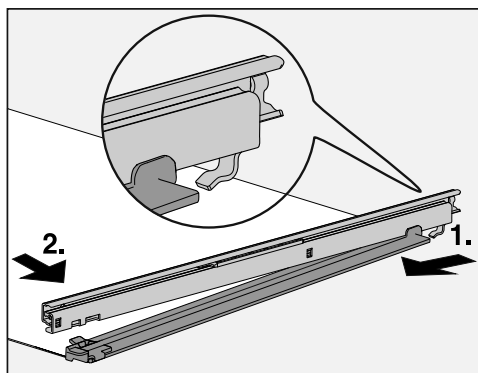

- To reattach the telescopic runners to the shelf after cleaning:
 1. Hook the telescopic runner on at the rear.
 2. Then clip the catches into position at the front.

Cleaning the interior and accessories

The appliance should be cleaned regularly (at least once a month).

Clean up any spills, stains, or food immediately. Do not allow them to dry and stick to the appliance.

- Clean the **interior** with a clean sponge, lukewarm water, and a little liquid dish soap.
- After cleaning, wipe with clean water and dry with a soft cloth.

The following parts **cannot be cleaned in a dishwasher**:

- the freezer drawers
- the trims
- the shelves
- the telescopic runners on the shelves
- the cool packs
- Clean these accessories by hand.
- Wipe the telescopic runners with a damp cloth to clean them.

Be careful not to wash out the special lubricant in the telescopic runners during cleaning.

- Leave the door open for a short while to air the appliance sufficiently and prevent odor buildup.

Cleaning the door seal

 Risk of damage as a result of incorrect cleaning.

If you treat the door seal with oils or grease, it can become porous.

Do not use any oils or grease on the door seal.

- The door seals should be cleaned regularly with clean water, and then wiped dry with a soft cloth.

Cleaning the ventilation gaps

A build-up of dust will increase the energy consumption of the appliance.

- The ventilation gaps should be cleaned on a regular basis with a brush or vacuum cleaner (you could use a Miele Vacuum Cleaner dusting brush, for example).

After cleaning



- Slide all shelves back into the appliance.
- Close the appliance door.
- Reconnect to the power supply and switch the appliance back on.
- Switch on the SuperFrost function for a while so that the freezer zone can cool down quickly.
- Once the temperature in the freezer zone is cold enough, you can place the food in the freezer drawers and return the drawers to the freezer.
- As soon as the freezer zone reaches a constant temperature of at least 0°F (-18°C), press the SuperFrost button to turn off the function.

Frequently Asked Questions

With the help of the following guide minor faults in the performance of the machine, some of which may result from incorrect operation, can be remedied without contacting the Service Department.

This guide may help you to find the reason for the fault, and how to correct it.

To prevent cold from escaping, open the appliance doors as little as possible until the fault has been corrected.

Problem	Possible cause and solution
The appliance is not getting cold, the interior lighting does not come on when the door is opened, and the display is not lit up.	The appliance is not switched on and the power supply symbol  is lit up in the display. ■ Switch the appliance on.
	The plug is not properly plugged into the electrical outlet. ■ Insert the plug correctly into the socket. The power supply symbol  appears in the display when the appliance is switched off.
	Check whether the fuse has tripped. There could be a fault with the appliance, the household electrical wiring or another electrical appliance. ■ Contact a qualified electrician or Miele Technical Service for assistance.
The compressor runs continuously.	Not a fault. To save energy, the compressor runs at a lower speed when less cooling is required. This increases the compressor run time.

Frequently Asked Questions







Problem	Possible cause and solution
<p>The compressor is turning on more frequently and for longer periods of time; the temperature in the appliance is too low.</p>	<p>The ventilation gaps in the cabinetry have been covered or become too dusty.</p> <ul style="list-style-type: none"> ■ Do not block the ventilation gaps. ■ Clean the ventilation gaps on a regular basis to remove any dust.
	<p>The door has been opened too frequently, or a large amount of fresh food has been placed inside and/or frozen at the same time.</p> <ul style="list-style-type: none"> ■ Only open the door when necessary and for as short a time as possible. <p>After a while, the temperature will return to normal by itself.</p>
	<p>The appliance door is not properly closed. A thick layer of ice may have already formed in the freezer.</p> <ul style="list-style-type: none"> ■ Close the appliance door. <p>After a while, the temperature will return to normal by itself.</p> <p>If a thick layer of ice has already formed, this will affect cooling and increase energy consumption.</p> <ul style="list-style-type: none"> ■ Defrost the appliance and clean it.
	<p>The ambient temperature is too high. The higher the ambient temperature, the longer the compressor has to run.</p> <ul style="list-style-type: none"> ■ See the “Installation location” section in the “Installation information”.
	<p>The appliance was not properly installed in the niche.</p> <ul style="list-style-type: none"> ■ See the “Installation information” and “Building in the appliance” sections.

Frequently Asked Questions





Problem	Possible cause and solution
<p>The compressor is turning on more frequently and for longer periods of time; the temperature in the appliance is too low.</p>	<p>The temperature setting is too low.</p> <ul style="list-style-type: none"> ■ Correct the temperature setting.
	<p>A large amount of food was put in for freezing at once.</p> <ul style="list-style-type: none"> ■ See the information in the section on “Freezing and storing food”.
	<p>The SuperFrost function is still turned on.</p> <ul style="list-style-type: none"> ■ To save energy, you can switch the SuperFrost function off early yourself.
<p>The compressor comes on less and less often and for shorter periods of time. The temperature in the appliance rises.</p>	<p>This is not a fault. The temperature setting is too high.</p> <ul style="list-style-type: none"> ■ Correct the temperature setting. ■ Check the temperature again after 24 hours.
	<p>The food begins to thaw. The ambient temperature is too low for this appliance. If the ambient temperature is too low, the compressor will run less frequently. This may cause the freezer to become too warm.</p> <ul style="list-style-type: none"> ■ See the information in the section on “Installation – Installation location”. ■ Increase the ambient temperature.
<p>An LED indicator light is flashing at the back of the refrigerator at the bottom near the compressor (depending on model). The electronic for the compressor is equipped with an operation and fault diagnosis LED indicator light.</p>	<p>The indicator light flashes several times every 5 seconds. A fault has occurred.</p> <ul style="list-style-type: none"> ■ Contact Customer Service.
	<p>The indicator light flashes regularly every 15 seconds. This is not a fault. This flashing is normal.</p>

Frequently Asked Questions

Messages in the display

Message	Possible cause and solution
The  symbol lights up in the display. You cannot switch the appliance off.	The safety lock has been activated. <ul style="list-style-type: none"> ■ Completely deactivate the safety lock (see “Selecting additional settings”, section “Activating and deactivating the safety lock”).
“F0 to F9” appears in the display.	There is a fault. <ul style="list-style-type: none"> ■ Contact Miele Technical Service.
“FE” appears on the display.	There is a fault. <ul style="list-style-type: none"> ■ Contact Miele Service.
The alarm symbol  lights up in the display. An alarm also sounds.	The door alarm has been activated. <ul style="list-style-type: none"> ■ Close the appliance door. The alarm symbol  will go out, and the alarm will stop sounding.
The alarm symbol  flashes in the display.	The temperature in the freezer zone has risen higher or fallen lower than the set temperature. This could be due to, for example: <ul style="list-style-type: none"> – the appliance door being opened too often, or being left open, – a large quantity of fresh food being placed in the freezer all at once without the SuperFrost function being turned on, or – a prolonged power outage. <ul style="list-style-type: none"> ■ Rectify the cause of the alarm. The alarm symbol  will go out, and the alarm will stop sounding. Depending on the temperature displayed, you should check whether food in the freezer has started to thaw or has defrosted. If it has, cook it before freezing it again.
The  symbol flashes on the display and the indicator light on the ice cube maker flashes when the ice cube maker is switched on.	The water supply line is not open. <ul style="list-style-type: none"> ■ Open the water supply line.

Frequently Asked Questions

Message	Possible cause and solution
<p>The ice cube maker  and alarm  symbols are flashing on the display. The indicator light on the ice cube maker is also flashing.</p>	<p>There is a fault with the ice cube maker.</p> <ul style="list-style-type: none"> ■ Contact Miele Service.
<p>The power failure symbol , appears in the display and the alarm sounds.</p> <p>The temperature display will show the warmest temperature recorded in the freezer during a power failure or an interruption to the power supply.</p>	<p>There is a power failure: The temperature in the appliance over the last few days or hours has risen too high because of a power failure or interruption to the power supply.</p> <p>The appliance will go back to the last temperature setting when the power is restored.</p> <ul style="list-style-type: none"> ■ Press the OK button. <p>The warmest temperature displayed will disappear. The display will then revert to showing the current temperature in the freezer section.</p> <ul style="list-style-type: none"> ■ Depending on the temperature displayed, you should check whether food in the freezer has started to thaw or has defrosted. If it has, cook it before freezing it again.
<p>The  symbol has lit up on the display and the appliance is not cooling although the controls and the interior lighting are working.</p>	<p>Demo mode is on. This allows the appliance to be presented in the showroom without the cooling system being switched on. Do not activate this setting for domestic use.</p> <ul style="list-style-type: none"> ■ Turn off demo mode (see “Information for dealers - Demo mode”).

Frequently Asked Questions



Problems with the ice cube maker

Problem	Possible cause and solution
You cannot turn the ice cube maker on.	The appliance is not connected to the power supply or is not switched on. <ul style="list-style-type: none">■ Reconnect to the power supply and switch the appliance back on.
The ice maker is not producing any ice cubes.	The appliance and/or the ice maker is not turned on. <ul style="list-style-type: none">■ Turn on the appliance and/or the ice maker.
	The water intake is not open or has not been vented. <ul style="list-style-type: none">■ Open the water intake.■ Check that the water supply has been vented.
	The ice maker drawer is not closed properly. <ul style="list-style-type: none">■ Push the drawer all the way in.
	The appliance door has been opened too frequently, causing the compressor to turn on more frequently and the ice maker to ice up. <ul style="list-style-type: none">■ Only open the door when necessary and for as short a time as possible.
	The temperature in the freezer zone is too high. <ul style="list-style-type: none">■ Select a lower temperature.
	The water pressure is too low. <ul style="list-style-type: none">■ The water pressure must be between 121 and 87 psi (1.5 and 6 bar). Remember that it can take up to 24 hours for the production of ice cubes to commence.
The ice cube maker is only producing small ice cubes.	The size of the ice cubes depends on the quantity of water supplied. You are able to set this quantity as required. <ul style="list-style-type: none">■ To make larger ice cubes, increase the amount of water supplied to the ice cube maker.

Frequently Asked Questions

Problem	Possible cause and solution
<p>The ice cubes have an unpleasant odor or flavor.</p>	<p>The ice cube maker is in constant use and needs to be cleaned regularly.</p> <ul style="list-style-type: none"> ■ Rinse the ice cube maker and water supply line regularly (see “Cleaning and care - Rinsing the ice cube maker”).
	<p>The ice cube maker is seldom used. If you do not use it very often, ice cubes that are stored for a long period can absorb the taste and smell of other items.</p> <ul style="list-style-type: none"> ■ Empty the ice cube drawer if you are not going to use the ice cube maker for a long time. ■ Rinse the ice cube maker and water supply line regularly (see “Cleaning and care - Rinsing the ice cube maker”).
	<p>There is unpackaged/unwrapped food in the freezer section. Ice can absorb the taste and smell of unwrapped food.</p> <ul style="list-style-type: none"> ■ All food in the freezer section must be wrapped.
	<p>The ice cube drawer is dirty.</p> <ul style="list-style-type: none"> ■ If necessary, clean the ice cube drawer.

The interior lighting is not working.

Problem	Possible cause and solution
<p>The interior lighting is not working.</p>	<p>The refrigeration appliance has not been turned on.</p> <ul style="list-style-type: none"> ■ Turn the refrigeration appliance on. <p>To avoid overheating, the interior lighting switches itself off automatically after approximately 15 minutes if the appliance door is left open. If this is not the cause, there is a fault.</p> <div style="border: 1px solid gray; padding: 5px; margin: 5px 0;"> <p> Risk of electric shock due to exposed, live electrical components.</p> <p>When removing the lighting cover, there is a risk of coming into contact with live electrical components.</p> <p>Do not remove the lighting cover. The LED lighting may only be repaired or replaced by Customer Service.</p> </div> <div style="border: 1px solid gray; padding: 5px; margin: 5px 0;"> <p> Risk of injury from LED lighting.</p> <p>This lighting corresponds to risk group RG 2. If the cover is defective, there is a risk of eye injury.</p> <p>If the lighting cover is defective, do not look from a close range directly into the lighting with optical instruments (e.g., magnifying glass or similar).</p> </div> <ul style="list-style-type: none"> ■ Contact Customer Service.

Frequently Asked Questions

Other problems

Problem	Possible cause and solution
The door to the Freezer Zone will not open because it has been opened and closed too many times in succession.	This is not a fault. The suction caused by opening and closing the door is preventing the door from opening. Wait approx. 1 minute and then try again. It should now open without force.
Food has frozen together or to the wall.	The food packaging was not dry when loaded in the freezer. ■ Use a blunt instrument (such as a spoon handle) to carefully pry them apart.
An alarm does not sound even though the appliance door has been open for a long time.	This is not a fault. The alarm tone has been switched off in settings mode (see “Acoustic signals 🎵” under “Selecting additional settings”).
The external walls of the appliance feel warm.	This is not a fault. The warmth created by the evaporator is used to prevent condensation.

Causes of noises

Normal noises	Cause
Brrrrr...	A humming noise is made by the motor (compressor). This noise can get louder for brief periods when the motor switches on.
Blub, blub...	A gurgling noise can be heard when the coolant circulates through the pipes.
Click...	Clicking sounds occur whenever the thermostat switches the motor on or off.
Sssrrrrr...	You can sometimes just hear the sound of the fan inside the appliance.
Crack...	A cracking sound can be heard when materials expand inside the appliance.
Please bear in mind that a certain amount of noise is unavoidable (from the compressor and the coolant circulating through the system).	

Noises	Possible cause and solution
Rattling, clinking	The appliance is uneven. Realign the appliance using a spirit level, by raising or lowering the screw feet underneath the appliance or place something underneath it.
	The appliance is touching another appliance or piece of furniture. Move it away.
	Drawers, baskets or shelves are unstable or sticking. Check all removable items and refit them correctly.
	Bottles or containers are touching each other. Separate them.
	The transport cable clips are hanging loose at the back of the appliance. Remove the cable clips.

Customer Service

Contact in the event of a fault

In the event of a fault which you cannot remedy yourself, please contact your Miele dealer or Miele Customer Service.

You can book a Miele Service Call online at www.miele.com/service.

Contact information for Miele Customer Service can be found at the end of this document.

Please quote the model identifier and serial number of your appliance (SN) when contacting Miele Customer Service. Both pieces of information can be found on the data plate.

You will find the data plate inside your appliance.

Appliance warranty and product registration

You can register your product and/or view the manufacturer's warranty terms and conditions for Miele appliances and vacuum cleaners at www.mieleusa.com.

Demo mode

The appliance can be demonstrated in the showroom or at exhibitions in “Demo mode”. In this mode, the control panel and interior lighting are active but the compressor remains off.

Turning on demo mode



- Switch the appliance off by touching the On/Off button.
If this does not work, the safety lock is activated.

The temperature shown on the display will go out and the power connection symbol  appears.







- Touch and hold the  button.



- At the same time, briefly touch the on/off button (without letting go of the  button!).



- Keep your finger on the  button until the  symbol appears on the display.
- Release the  button.

Demo mode is on and the  symbol is illuminated on the display.

Information for dealers

Turning off Demo mode



The  symbol is illuminated in the display.



- Touch the settings sensor.



All symbols available for selection will appear in the display and the  symbol flashes.





- Touch the sensors for setting the temperature ( or ) repeatedly until the  symbol flashes in the display.



- Touch the OK sensor to confirm your selection.

The  symbol flashes in the display (meaning: Demo mode is active) and the  symbol is illuminated.



- Touch the  or  sensor so that the symbol  appears in the display (meaning: Demo mode is inactive).



- Touch the OK sensor to confirm your selection.

The selected setting will be adopted and the  symbol will flash.



- Touch the settings sensor to leave the settings mode. Otherwise the appliance will exit the settings mode automatically after approximately one minute.

Demo mode is turned off and the  symbol disappears.

Installation

Side-by-side

The appliance has two side-wall heaters encased in foam and can be installed side-by-side with other appliances. Each appliance must be installed in its own niche.

Please contact your dealer for specific information about which combinations will work with your appliance.

 **WARNING!** This appliance must be built in, otherwise it could tip over!

Install the appliance in accordance with the installation instructions.

 **Fire hazard and risk of damage!** The appliance must not be installed underneath a cooktop.

Installation location

This appliance should be installed in a dry, well-ventilated room.

When deciding where to install your appliance, please bear in mind that the energy consumption will increase if installed near to a heater, a cooker, or other appliance that gives off heat. Direct sunlight should also be avoided. The higher the room temperature, the longer the compressor has to run and the higher the energy consumption is.

When installing the appliance, please note:

- The electrical socket must be easily accessible in an emergency and not concealed behind the appliance.

- The plug and power cord must not touch the back of the appliance as they could be damaged by vibrations from the appliance.
- Do not plug other appliances into electrical sockets behind this appliance.

 **Risk of damage due to high humidity.**

In environments with high humidity, condensation can build up on external refrigeration appliance panels, which can cause corrosion.

Install the refrigeration appliance in a dry and/or air-conditioned room with sufficient ventilation.

After installation, make sure that the appliance doors close properly, the ventilation gaps are not covered, and the refrigeration appliance has been installed in accordance with these operating and installation instructions.

Installation

Climate class

The appliance is designed for use within specific ambient temperatures (climate range). Do not use in ambient temperatures for which it is not designed.

If the room is too cold, the compressor will turn off for too long, causing the internal temperature in the appliance to rise. In turn, this can result in food deteriorating and going off.

The climate class is stated on the data plate inside the appliance.

Climate class	Room temperature
SN	50°F to 90°F / 10°C to 32°C
N	60°F to 90°F / +16°C to +32°C
ST	60°F to 100°F / +16 to +38°C
T	60°F to 109°F / +16 to +43°C

A freezer from the SN climate class can operate without any difficulties in rooms with a cooler ambient temperature (down to +41°F/5°C).

Ventilation

 **WARNING! Fire hazard!**
Operation of the appliance is limited. Keep the ventilation slits free from obstruction.

 If the ventilation slits are not kept free and unobstructed the compressor will switch on more often and will run for longer.

This can cause higher energy consumption and to an increased compressor operating temperature, which can result in damage to the compressor.

Do not block the ventilation slits.

The air at the back wall of the appliance warms up. Therefore the cabinet must be constructed in such a way that ensures unhindered ventilation (see “Built-in dimensions”).

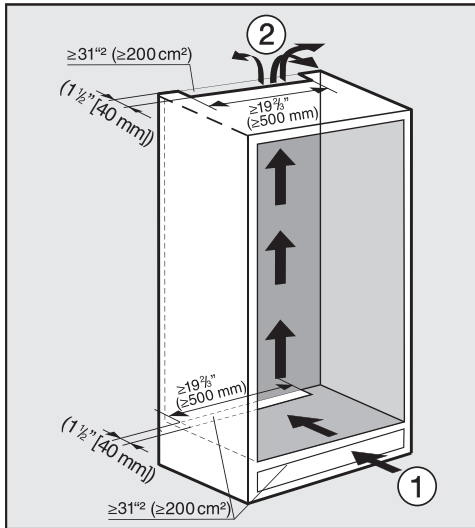

- The air influx ① enters via the toe-kick and the air outlet ② is at the top at the rear of the cabinet.
- To ensure ventilation an air channel of a minimum 9/16" (40 mm) depth must be provided at the back of the appliance.
- The ventilation slits in the toe-kick, in the cabinet and under the top of the cabinet must provide a total passage volume of at least 31 square inches to allow the warm air to dissipate unimpeded.

If you wish to fit a grille in the ventilation openings, the ventilation openings must be larger than 31 square inches. The passage volume of 31 square inches is the total area of the opening slits in the grille.

- Important! The larger the ventilation slits, the more economically the appliance will work.

The ventilation slits must not be blocked or obstructed in any way. Clean the ventilation slits on a regular basis.

Top ventilation gap

The ventilation gap at the top of the appliance can be constructed in different ways:

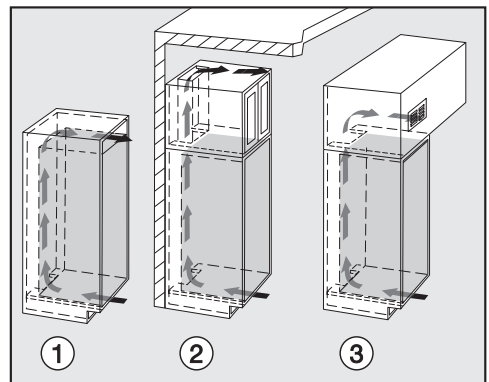

- ① Directly above the appliance with a ventilation grille (free airflow of at least 31 sq inches (200 cm²))
- ② Between the kitchen cabinetry and the ceiling
- ③ In a suspended ceiling

Installation

Door panel

The required door panel must be min. 5/8" (16 mm) and max. 3/4" (19 mm) thick.

- Weight of the door panel

⚠ If the door panel is too heavy damage can occur.

Installing a door panel which is heavier than the maximum permitted weight could damage the hinges. This can cause subsequent functional problems.

Before installing the door panel, ensure that the weight of the door panel does not exceed the maximum permitted weight.

Before installing the cabinet door, ensure that the weight of the door does not exceed the maximum permitted weight.

Appliance	Maximum weight of cabinet door in lbs (kg)
FNS 37492 iE	57 (26)

Before installing the appliance

- Before installation, remove the bag of installation and other accessories from the appliance and remove the profile strip from the outer appliance door.
- **Do not remove** the following from the back of the appliance

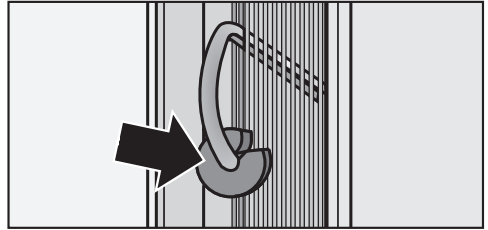

- the spacers (depending on the model). They ensure the distance required between the back of the appliance and the wall.
- the bags located in the metal grille (heat exchanger, depending on model). These are required for the functioning of the appliance. Their contents are not toxic or hazardous.
- Remove the cable clips from the back of the appliance.

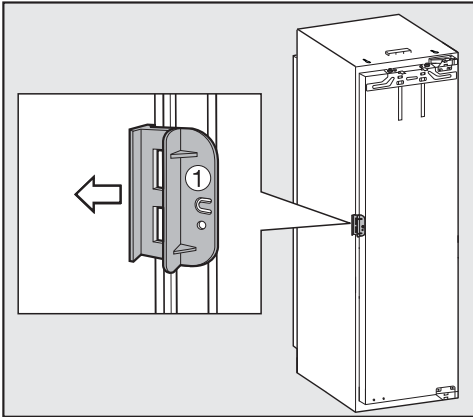

- Open the appliance door and remove the red transport clips ① (depending on model).

Wall spacer at the back

At a furniture depth of less than 21 3/4" (553 mm), you can remove the wall spacer from the back of the appliance so that you can push the appliance right into the niche.

Removing the wall spacer can increase energy consumption as there is then a smaller ventilation area.

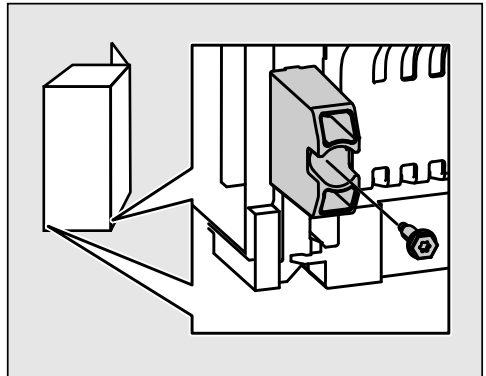

- Loosen the screw and remove the wall spacer.

Installation

Installation dimensions

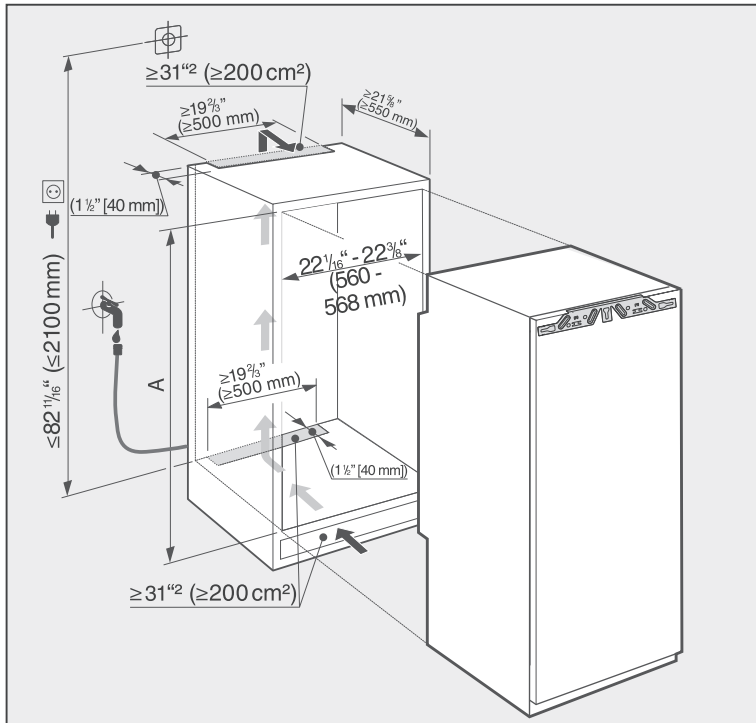

* The declared energy consumption was achieved with a niche depth of $22\frac{1}{16}''$ (560 mm). The appliance is fully capable of functioning at a niche depth of $21\frac{5}{8}''$ (550 mm), but will consume slightly more energy.

If the appliance is suitable for installation in a niche, ensure before installation that it has precisely the correct dimensions. The specified ventilation grille dimensions must be observed to ensure that the appliance functions correctly.

Limiting the opening angle of the appliance door

The door hinges are set at the factory to enable the appliance door to be opened wide.

However, if the opening angle of the door needs to be limited for any reason, the hinge can be adjusted to accommodate this.

If the appliance door hits an adjacent wall when opened, for example, the opening angle can be limited to approx. 90°:

The locking pins for limiting the door opening must be installed before the appliance is installed.

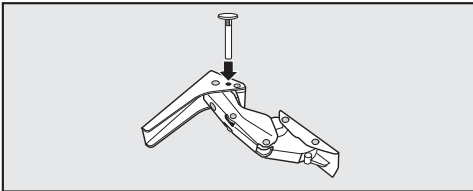

- Insert the locking pins supplied for limiting the door opening into the hinges from above.

The appliance door opening angle is now limited to approximately 90°.

Changing the door hinges

Always change the door hinging with the assistance of another person.

The appliance is supplied with right-hand hinging. If left-hand hinging is required, the hinges must be changed:

To change the door hinging, you will need the following tools:

- Open the appliance door.

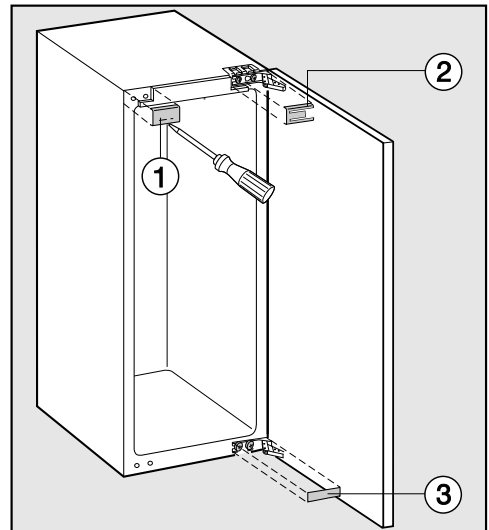

- Lift off the covers: ①, ②, and ③.

Installation

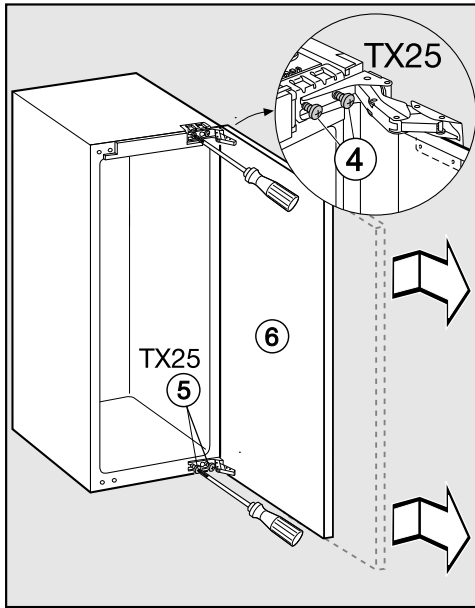

- Slightly loosen the hinge screws: ④ and ⑤.
- Push the appliance door ⑥ outward, take it off its hinges and place it to one side.

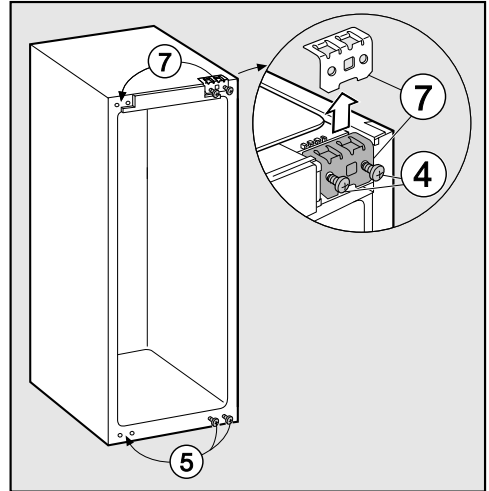

- Undo the screws ④ completely.
- Install the bracket ⑦ on the opposite side and attach the screws ④ loosely.
- Undo the screws ⑤ completely and loosely screw them in on the opposite side.

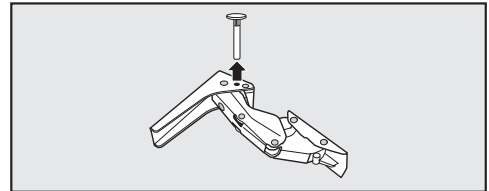

- If you have inserted pins into the hinges to limit the opening angle of the door, lift the pins up and out of the hinges.

Removing the soft-close mechanism

⚠ Warning! The soft-close mechanism folds in when dismantled!
Danger of injury!

- Place the door on a stable surface with the front facing down.

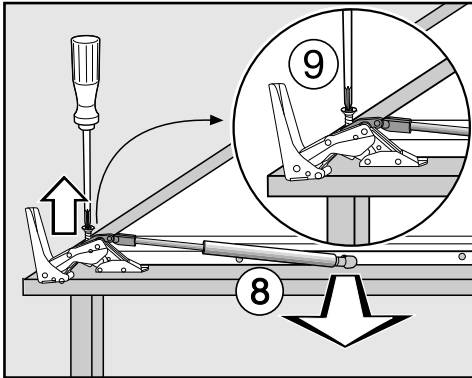

- Remove the soft-close mechanism (8) from the ball joint.
- Unscrew the mount (9) and pull the soft-close mechanism (8) toward you and off.

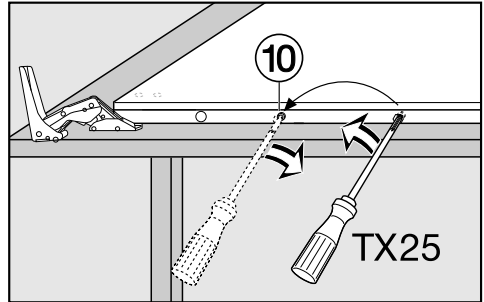

- Using a screwdriver, remove the ball joint (10) and screw it into the adjacent hole.
- Now turn over the appliance door so that the front is facing up (hinges remain open).

Danger of injury!
Do **not** close the hinges.

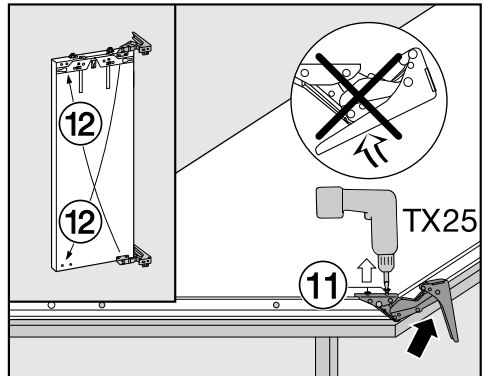

- Remove the screws (11).
- Replace the hinges in their diagonally opposite corners (12).

Installation

Fastening the soft-close mechanism

- Now turn over the appliance door so that the outer side faces downward.

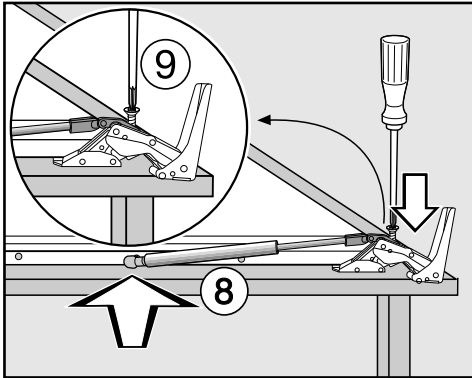

- Screw the mount (9) onto the hinge and firmly tighten.
- Open out the soft-close mechanism (8), and hook it onto the ball joint.

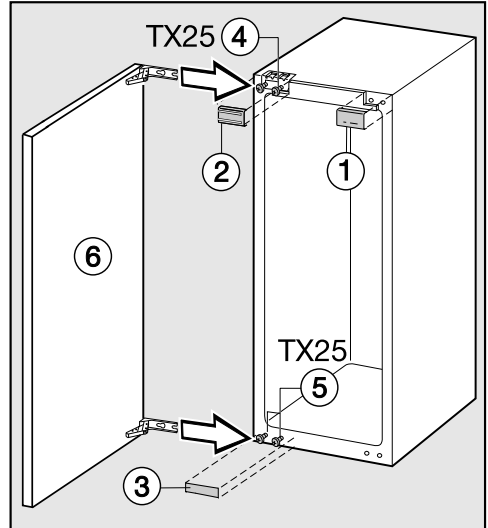

- Hang the appliance door (6) onto the pre-fitted screws (4) and (5), and securely tighten the screws (4) and (5).
- Replace the covers: (1), (2), and (3).

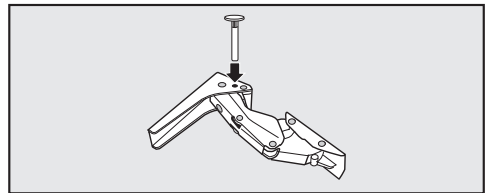

- Refit the locking pins into the top of the hinges to prevent the door from opening too far.

Building in the appliance

Two people are required to install the appliance.

- Install the appliance in a stable, solid cabinet, positioned on an even and level floor.
- Secure the cabinetry against tipping.

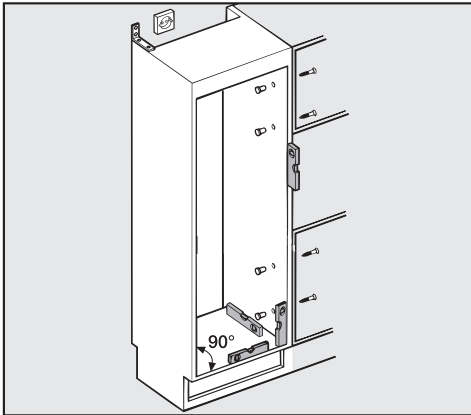

- Use a spirit level to align the cabinet. The cabinet corners must be at 90° angles to each other, otherwise the cabinet door will not sit straight on all 4 corners.
- The required ventilation gaps must be provided (see “Installation – Installation notes”).

To install the appliance, you will need the following tools:

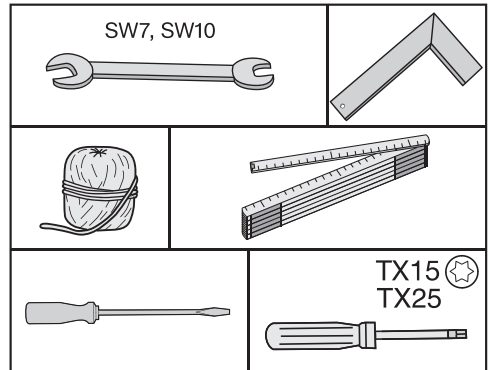





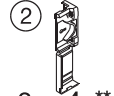

Installation

Parts required for installation:

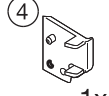
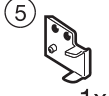
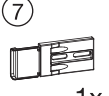
All installation parts are number-coded. This coding is also used in the installation instructions.

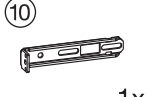
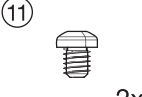
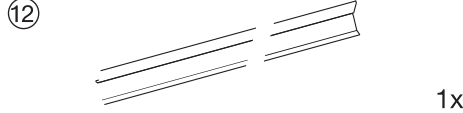
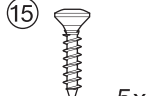
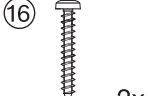
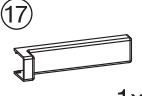
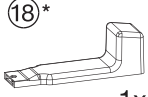



- For building the appliance into the niche:

 1x	 2x+4x**	 2x+4x**	
 1x	 1x	 1x	 2x
 1x	 1x	 2x	
 1x			
 5x	 2x	 1x	
 1x	 2x		

* These parts are only supplied with appliances with a niche height of 55" (140 cm) or more.

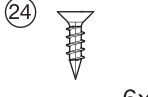
** Number depends on niche height; maximum number applies to appliances requiring a niche height of 55" (140 cm) or more (also contains additional installation parts for fitting large or divided cabinet doors).

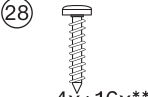
- For installing the cabinet door:

 6x	 1x	 4x+16x**
 1x		

** Number depends on niche height. Also contains additional installation parts for fitting large or divided cabinet doors.

All installation instructions given are for a **right-hand hinged appliance**. If you have converted the appliance to left-hand hinging, you will need to adapt these instructions accordingly.

Preparing the appliance

- Position the appliance directly in front of the cabinet niche.

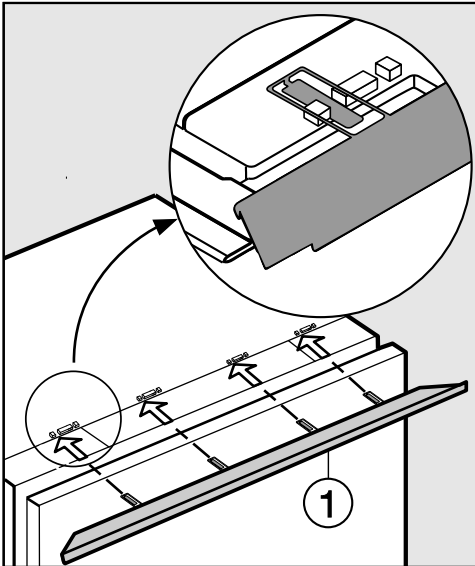

- Push the filler strip lugs ① into the holders from the front.

If the appliance is hinged on the left, slide the lugs into the right-hand opening of the holder.

 Risk of damage to the securing bracket and cover.

The cover on the securing bracket can easily become detached. Always close the cover as soon as you have finished working on the bracket.

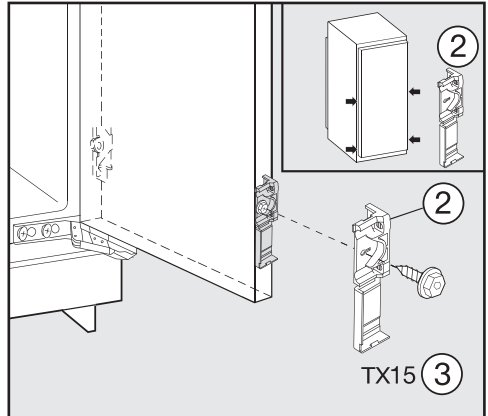

- Loosely screw the securing brackets ② into the pre-drilled holes in the appliance door using the hex screws ③.

Tip: Secure a pair of brackets in the handle area of the door.

Installation

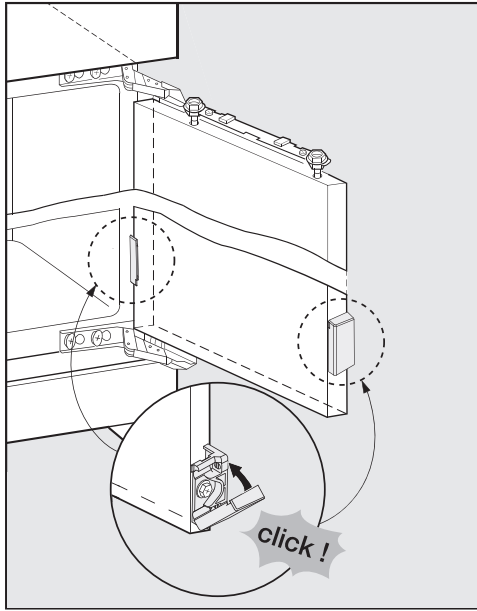

- Close the covers.
- Push the appliance two-thirds of the way into the built-in niche. Take care not to trap the power cord when pushing the appliance into its niche.

Tip: Tie a piece of string to the plug to “lengthen” the power cord; this will help you to push the appliance into position. Pull the power cord through the cabinet by the other end of the string so that the appliance can be connected to the power supply easily after installation.

With 5/8" (16 mm) thick cabinet walls only:

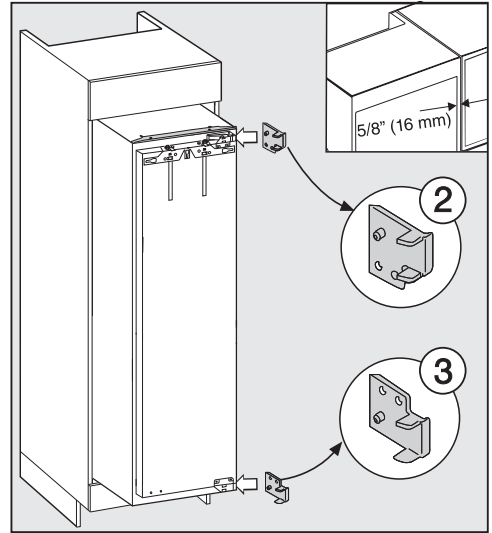

- Clip the spacers ④ and ⑤ onto the right of the hinges.
- Open the appliance door.

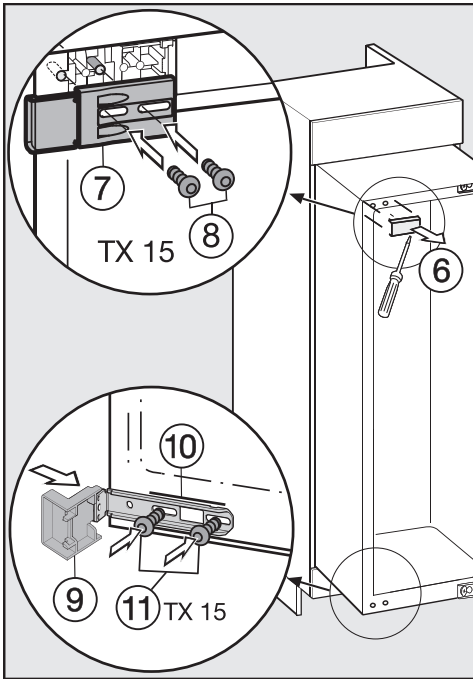

- Remove the cover ⑥.
- Loosely fit the connecting bracket ⑦ using the screws ⑧.

Tip: Do not tighten the screws, to allow for the position of the connecting bracket to be adjusted.

- Push the contact component ⑨ onto the fixing bracket ⑩.
- Loosely fit the securing bracket ⑩ using the screws ⑪.

Tip: Do not tighten the screws, to allow for the position of the connecting bracket to be adjusted.

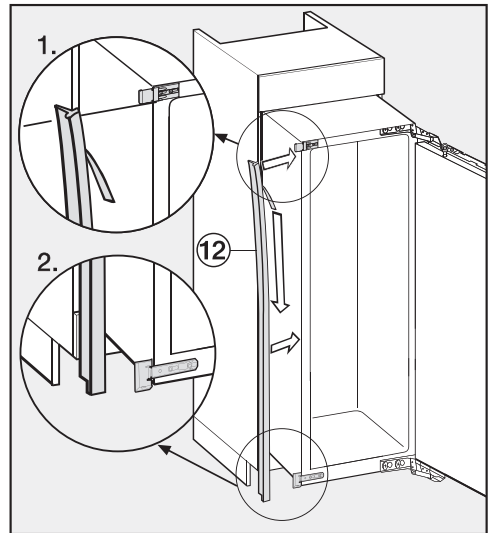

- Carefully remove the protective film from the sealing strip ⑫.

- Stick the sealing strip ⑫ onto the side of the appliance on which the door will open, flush with the front.

1. Align the sealing strip with the bottom edge of the top fixing bracket.
2. Stick it down along its entire length.

Installation

Building in the appliance

If the appliance is pushed too far into the niche, the appliance door may not close properly once the cabinet door has been fitted. This can cause ice to build up, condensate to accumulate, and cause the appliance to malfunction. These can all lead to increased energy consumption.

Push the appliance into the built-in niche, making sure a gap of **1 5/8" (42 mm)** is maintained all around between the appliance casing and the front of the cabinet side walls.

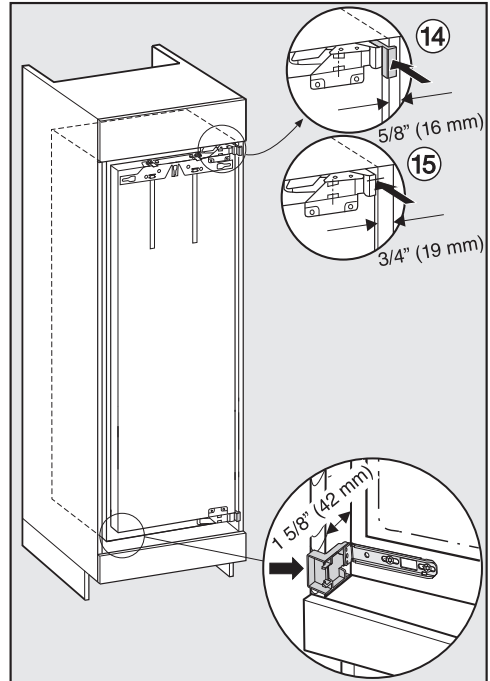

- Now push the appliance into the niche until all fixing brackets at the top and bottom are touching the front edge of the cabinet side wall.
- ⑬ **5/8" (16 mm) thick walls:**
The spacers should touch the front edge of the cabinet side walls at the top and bottom.
- ⑭ **3/4" (19 mm) thick walls:**
The front edges of the top and bottom hinges should be flush with the front edge of the cabinet side wall.

This ensures a distance of **1 5/8" (42 mm)** to the front edges of the cabinet unit side walls all the way round.

Important for cabinetry with door fittings (such as stubs and seals).

Take the dimensions of the fittings into account.

Check to make sure there is a gap all round of **1 5/8" (42 mm)** to the front edges of the door fittings.

- Pull the appliance forward by the appropriate dimension.

Tip: If possible, remove the door fittings and push the appliance into the niche until all securing brackets at the top and bottom are touching the front edge of the cabinet side wall.

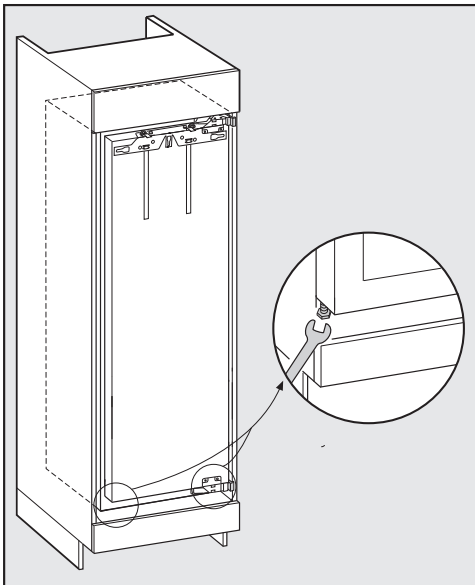

- Align the appliance on both sides via the adjustable feet so that it stands level.

Securing the appliance in the niche

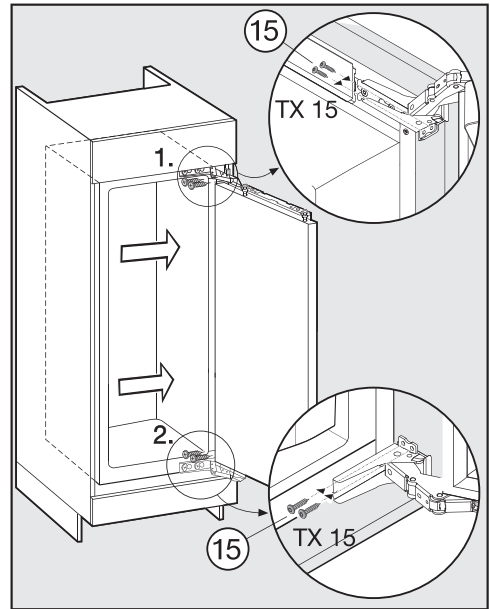

- Push the appliance onto the cabinet wall on the hinge side.
- Screw the particle board screws (15) through the hinge plates at the top and bottom to secure the appliance to the housing unit.

Installation

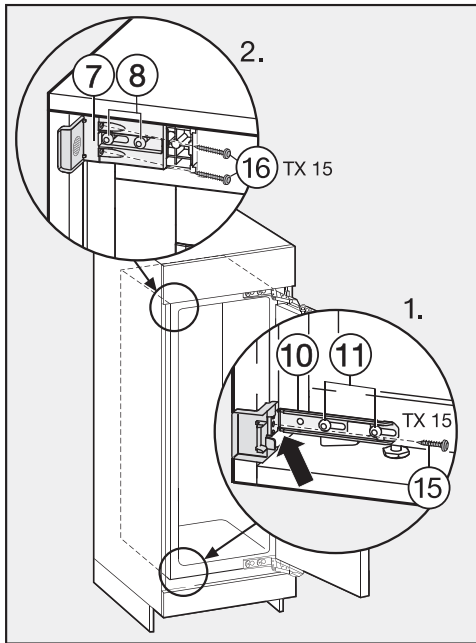

- Push the loose securing bracket against the cabinet wall.
- Fix the securing bracket (10) to the cabinet wall with the screw (15).

Tip: Pre-drill the hole.

The appliance must not pull back into the unit, as otherwise the gap of 1 5/8" (42 mm) will not be maintained all the way round.

Push the protruding bracket toward the cabinet wall using your thumb while tightening the screws.

- Fix the securing bracket (7) to the cabinet wall with the screws (8) and (16).

Tip: Pre-drill the holes.

- Re-tighten screws (8) and (11).

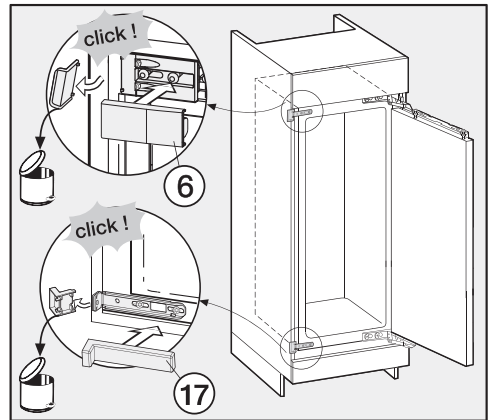

- Snap off any protruding ends from the securing bracket. They are no longer required and can be disposed of.
- Place the covers (6) and (17) on the securing bracket.

Only for an appliance with a niche height greater than 55" (140 cm)

To give the appliance additional security in the niche, push the rods supplied between the appliance and the cabinet base:

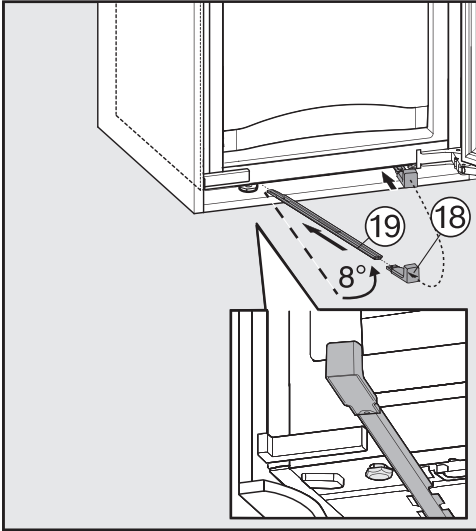

- First secure the handle (18) to one of the stabilizing rods (19).
- Use the handle to push the stabilizing rod (19) into the guide as far as it will go. Remove the handle (18) and fit it to the other stabilizing rod supplied and push this into its guide as far as it will go.

Tip: Keep the handle somewhere safe in case you ever need to fit the appliance into a new housing unit.

- Close the appliance doors.

Installing the cabinet door

If installed in a run of units, make sure that the top edge of the cabinet door is at the same height as neighboring unit doors.

The cabinet door must be installed level, and not under tension.

The next section gives instructions on how to install a cabinet door that is at least 5/8" - 3/4" (16 - 19 mm) thick.

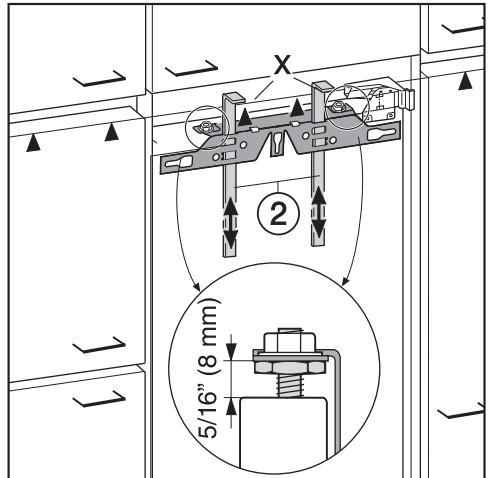

- The distance between the appliance door and the mounting frame is set to 5/16" (8 mm) at the factory. Check this distance and adjust it if necessary.
- Push the installation aids (2) to the height of the cabinet door. The lower contact edge X of the installation aids must be at the same height as the upper edge of the cabinet door to be installed (▲ symbol).

Installation

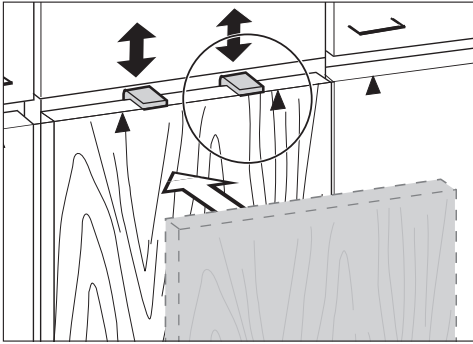

Tip: Push up the installation aids ② together with the cabinet front until they are at the same height as the neighboring unit doors.

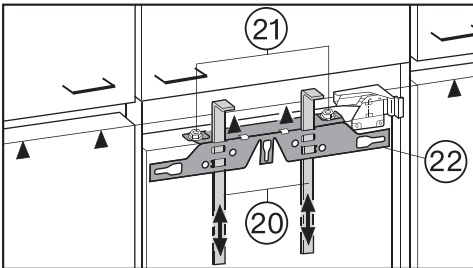

■ Unscrew the nuts ③ and remove the mounting frame ④ together with the installation aids ②.

■ Place the cabinet door on a stable surface with the outer side facing downward.

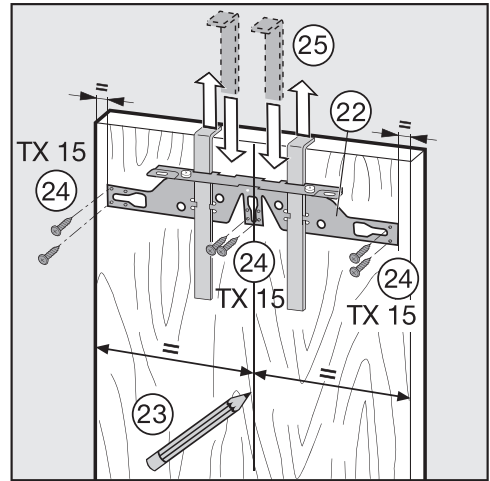

■ Draw a faint central line with a pencil on the inside of the cabinet door ⑤.

■ Hang the mounting frame ④ with the installation aids on the **inside** of the cabinet door. Align the mounting frame centrally.

■ Attach the mounting frame securely using at least 6 short chipboard screws ⑥. (On raised paneled doors, only use 4 screws on the edges.) Pre-drill holes into the cabinet door if necessary.

■ Pull the installation aids upward to remove them ⑦.

Turn them around and push them all the way into the middle slots on the mounting frame for safekeeping.

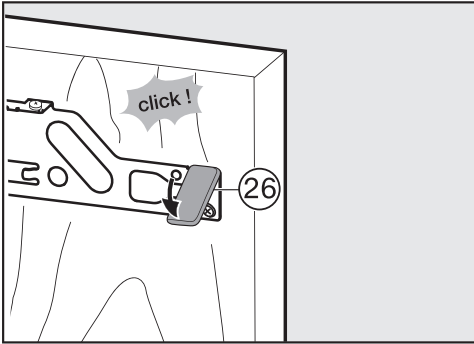

- Attach the side cover (17) to the mounting frame on the side opposite the hinge.
- Turn the cabinet door over and attach the handle (if required).

- Open the appliance door.

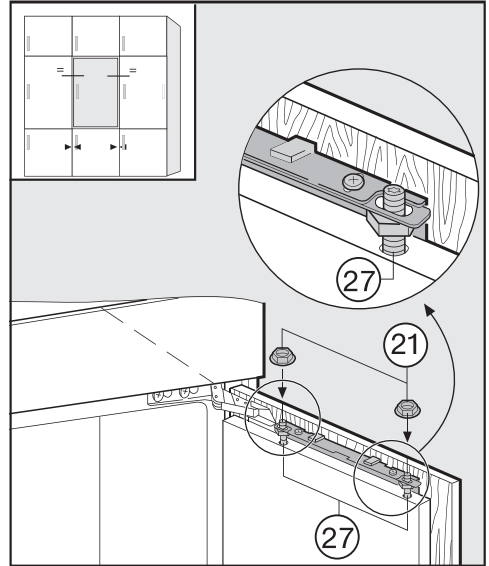

- Hang the cabinet door on the adjusting bolts (8).
- Screw the nuts (3) loosely onto the adjusting bolts.
- Close the door and check the distance between the door and adjacent cabinet doors. The distance should be the same.

Adjusting the position of the door

Check the distance between the door and adjacent cabinet doors. The distance should be the same.

Installation

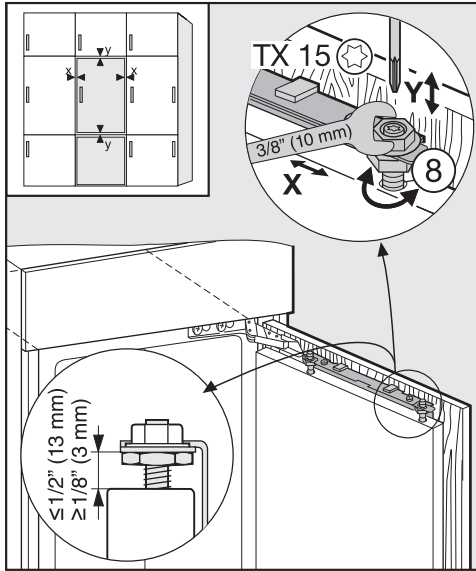

X: side adjustments

- Move the cabinet door.

Y: height adjustment

The distance between the appliance door and the mounting frame is set to 5/16" (8 mm). Only adjust the distance within the specified range.

- Turn the adjusting bolts ⑳ with a screwdriver.

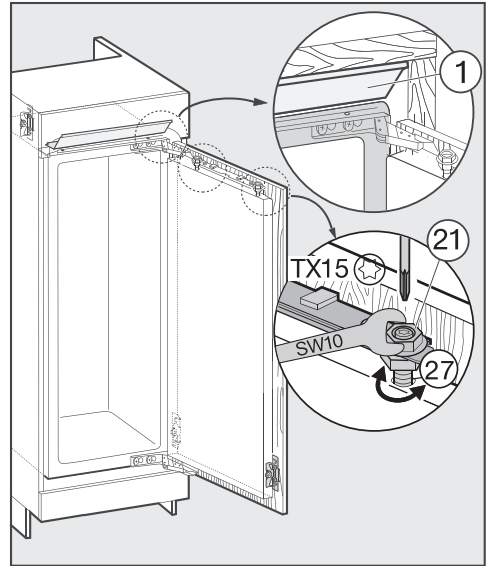

- While counterholding the adjusting bolts ⑳ with a screwdriver, tighten the nuts ㉑ with a wrench.
- The filler strip ① must not protrude; it must completely disappear into the niche.

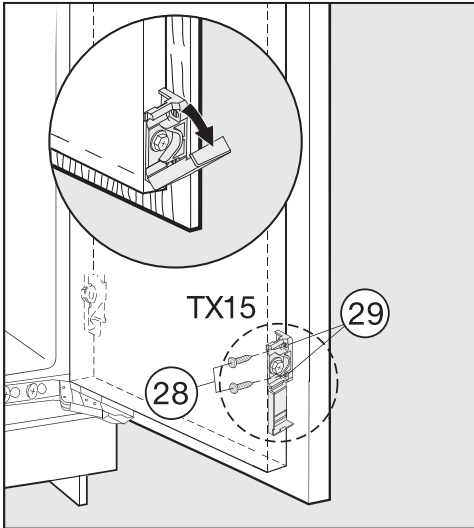

- Open the cover.
- Fit the screws ②⑧ into the holes ②⑨.

Tip: Pre-drill the holes.

⚠ Risk of damage to the securing bracket and cover.

The cover on the securing bracket can easily become detached.

Always close the cover as soon as you have finished working on the bracket.

- Close the cover and close the door.

Z: depth adjustment

Check the distance between the cabinet door and the housing unit. A distance of approximately 1/16" (2 mm) is required.

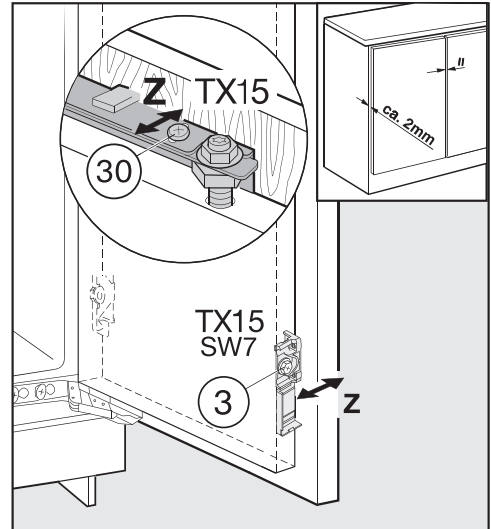

- Loosen screws ③⑩ and ③.
- Tighten all the screws again.

Installation

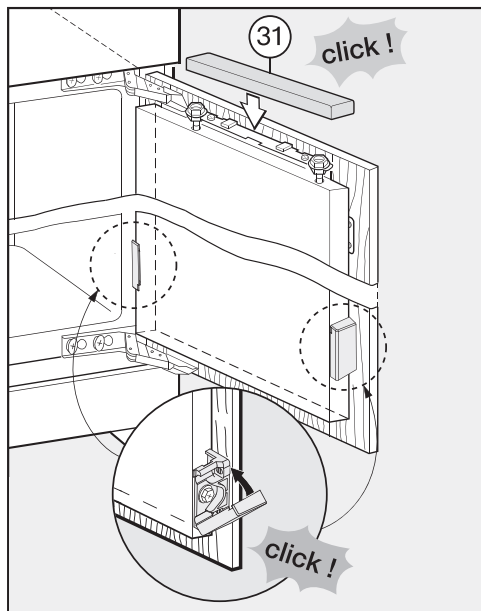

The appliance is properly installed in the niche if:

- the door closes properly
- the door does not touch the housing unit
- the seal on the top corner of the handle side is firmly seated
- To double check place a flashlight in the appliance and close the door. Turn the lights out in the room. If you can see any light shining out from the sides, double check the individual installation steps.

- Replace the cover ③① and click it into place.
- Close the covers on the securing brackets.

Water connection

Information on the fresh water connection

 Risk of injury and appliance damage if appliance is not connected properly.

Failing to connect the appliance properly can result in personal injury and/or material damage.

The appliance may only be connected to the fresh water connection by qualified technicians.

 Disconnect the refrigeration appliance from the power supply before connecting it to the water supply.

Close the faucet before connecting the refrigeration appliance to the water supply.

 Risk to health and risk of damage due to contaminated water.

The quality of the incoming water must conform to the requirements for drinking water in the country where the refrigeration appliance is being used.

Connect the refrigeration appliance to the drinking water supply.

Connection to the water supply must comply with the applicable regulations in the country where the appliance is being installed. All appliances and systems used to supply water to the refrigeration appliance must also comply with the applicable regulations in the respective country.

The appliance is only suitable for connection to a cold water supply, which

- is directly connected to the water supply in order to ensure a circulation of the water in the cold water line.

Avoid using a water line in which the water is allowed to pool. This can affect the taste of water and ice cubes.

- withstands the operating pressure.
- fulfills the hygiene regulations.

Water pressure on-site:

- Minimum: 21.76 psi (1.5 bar)
- Maximum: 87.02 psi (6 bar)

A shut-off valve must be provided between the water line and the water supply of the building to ensure that the water supply can be cut off if necessary.

Make sure that the shut-off valve is still accessible after the appliance has been installed.

 Risk of damage!

If the water supply is cut off while the ice cube maker is still in use the water intake pipe can freeze up.

Turn the ice cube maker off if the water supply is interrupted (e.g. while on vacation).

Installation

Before establishing the fresh water connection, ensure that the appliance is disconnected from the power supply.

The fresh water connection is at the back of the appliance, at the bottom.

The connection parts included with the appliance permit the connection of various water lines (water line not supplied). Do not connect old water lines that have been used before.

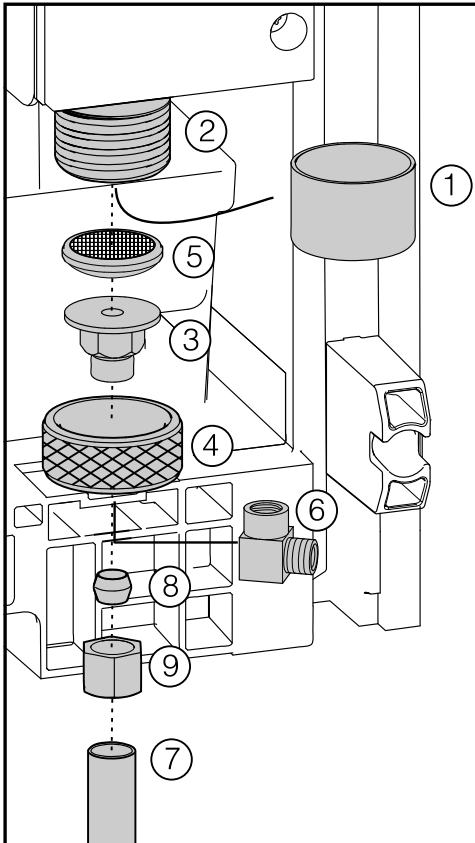

The solenoid valve ② has a metric R 3/4 connection thread.

- Remove the cap ① from the solenoid valve ②.
- Insert the adapter ③ into the union nut ④.

⚠ Risk of damage!
Do not insert the water filter the wrong way around, as this can cause damage.

- Insert the water filter ⑤ with the depression facing downward toward the adapter ③.

⚠ Risk of damage!
Do not overtighten the union nut, as this can cause damage.

- Connect the union nut ④ to the solenoid valve ②, and tighten it.
- If you want to divert the water line by 90°, screw on the elbow ⑥.

In case of a water line with a 1/4" thread:

- Connect the water line ⑦ (e.g., copper) to the adapter ③ or elbow ⑥ using the clamping ring ⑧ and nut ⑨.

In case of a water line with a 7/16"-24 UNS thread:

- Connect the water line ⑦ directly to the adapter ③ or elbow ⑥ (a clamping ring ⑧ and nut ⑨ are not required).

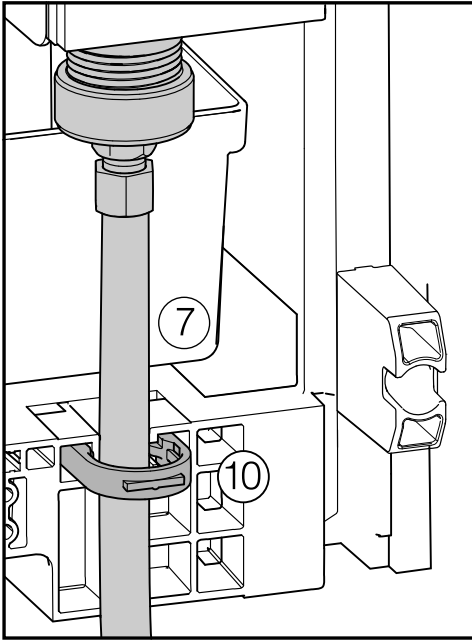

- Secure the water line ⑦ to the casing using the retaining clip ⑩.
- Slowly open the faucet in the water supply line and check the whole water system for leaks.
- The appliance can now be connected to the power supply (see “Electrical connection”).

When pushing the appliance into the niche, do not bend or damage the water line.

- Push the appliance into its final position.

Electrical connection

⚠ Danger of electric shock!
The appliance must only be switched on when it has been installed in accordance with the installation instructions.

Ground the appliance.

The appliance must not be grounded via a gas pipe.

If in doubt, have a suitably qualified and experienced electrician check that the installation complies with relevant regulations.

Do not install a fuse into neutral current or grounding electrical circuit.

Do not use extension cords or ungrounded (two prong) adapters.

Do not use a frayed or damaged power cord.

⚠ Danger of electric shock!
For protection against electric shock this appliance is equipped with a pole-free plug which is protected against reverse polarity. The plug must be grounded in the usual way. Do not remove the round grounding connector pin from the plug.

Use only a grounded plug adapter.

Installation

Wait for 1 hour after installation before plugging the appliance into the power supply. This allows coolant and refrigerant oil to settle in accordance with regulations.

Ensure that the voltage of the main power supply corresponds with the connection voltage of the appliance. A power supply of 110 - 120 V, 60 Hz and 15 Amp (20 Amp for side-by-side installation) with a NEMA 5-15 molded plug, which is protected by a main switch or a fuse, is required to operate the appliance.

The manufacturer recommends operating the appliance on a separate circuit to avoid overloading the electrical circuit.

All relevant legal electrical, fire and building regulations must be observed when installing the socket and/or the appliance.

In certain countries appliances are required to be connected to the electrical supply via a wall-mounted ON/OFF switch.

To avoid the risk of fire, electric shock or other injuries installation and connection of the appliance must be carried out by a suitably qualified electrician in accordance with all relevant local and national regulations and standards, including fire prevention.

The outlet must be easily accessible in an emergency so that the appliance can be quickly disconnected from the electrical supply in case of an emergency.

The socket must be located so that the upper edge is a maximum 82" (2100 mm) distance from the upper edge of the base of the kitchen cabinet.

If the outlet is no longer accessible once the appliance has been installed, an all-pole disconnect device with a contact opening of at least 1/8" (3 mm) must be present on site. The disconnect device may be circuit breaker, a fuse, or a contactor (compliant with local regulations).

The plug and power cord must not come into contact with the back of the appliance as vibrations can cause damage to these components. This, in turn, could result in a short circuit.

Do not plug in other devices behind this appliance.

Do not connect the appliance to an inverter such as those used with an autonomous energy source e.g. **solar power**. When switched on, peak loads in the system can cause the safety switch-off mechanism to be triggered. This can damage the electronic unit. The appliance must not be used with so-called **energy-saving devices** either. These reduce the amount of energy supplied to the appliance, causing it to overheat.

If the power cord needs to be replaced, this must be done by a qualified technician.

**Please have the model and serial number
of your appliance available when
contacting Customer Service.**

The Miele logo consists of the word "Miele" in a bold, white, serif font, set against a solid black rectangular background.

U.S.A.

Miele, Inc.

National Headquarters

9 Independence Way
Princeton, NJ 08540
Phone: 800-843-7231
Fax: 609-419-4298
www.mieleusa.com

Customer Service & Support

Phone: 888-99-MIELE(64353)
Fax: 888-586-8056
service@mieleusa.com

International Headquarters

Miele & Cie. KG
Carl-Miele-Straße 29
33332 Gütersloh
Germany

Canada

**Importer
Miele Limited**

Headquarters and Miele Centre

161 Four Valley Drive
Vaughan, ON L4K 4V8
www.miele.ca

Customer Care Centre

Phone: 800-565-6435
905-532-2272
customercare@miele.ca

