

Diagrams

◀30"▶

Unit Dimensions

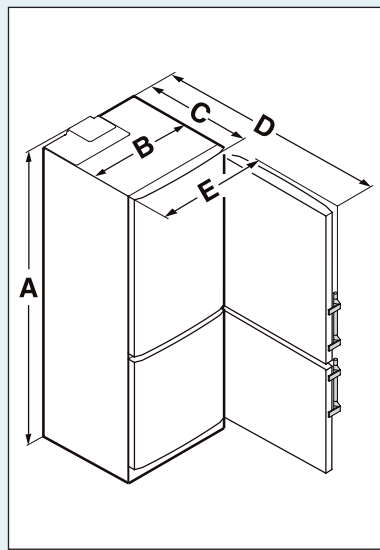

- A. 79-1/2" (2020 mm)
- B. 29-3/8" (747 mm)
- C. 24-13/16" (630 mm)
- D. 52-3/8" (1330 mm)
- E. 31-1/8" (791 mm)

Ventilation Requirements

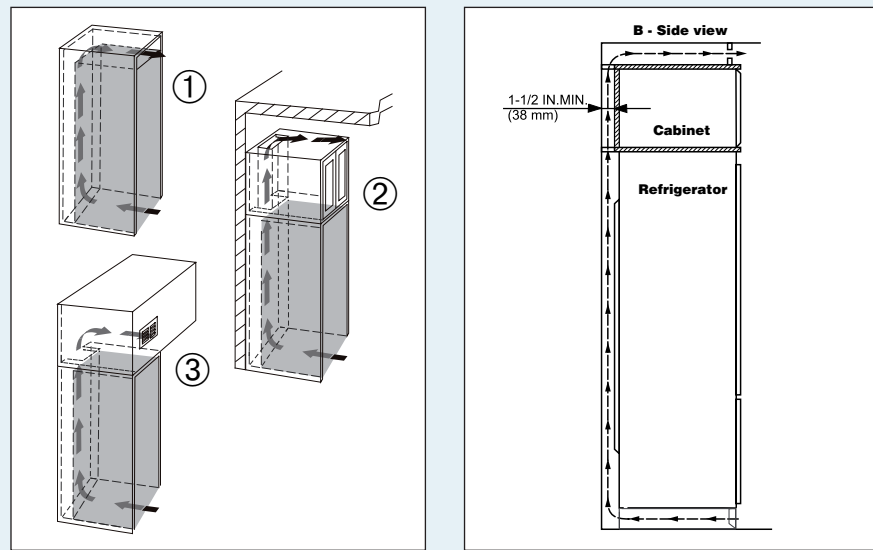

Do not restrict the air flow. The opening can either be directly over the appliance ①, above the cabinet and below the ceiling ② or through a vent installed in a soffit ③. The cabinet height as specified at 80" (2032 mm) will create a 1-5/16" (33 mm) gap above the appliance providing optimal air flow over the top of the appliance for its efficient operation. Be sure to consider the possibility of having to raise some of the leveling legs in order to level the appliance when installing. If you adjust the height of the appliance - it will effectively reduce air flow. Therefore leave yourself some room for adjustment.

IMPORTANT

The section between the freezer door and the floor must not be covered.

The refrigerator is designed to allow proper air flow when the appliance is installed up against the wall. A minimum space of 1 1/2" is required behind the cabinet when venting above an upper cabinet which is installed flush to the top of the appliance.

Cabinet Opening Dimensions

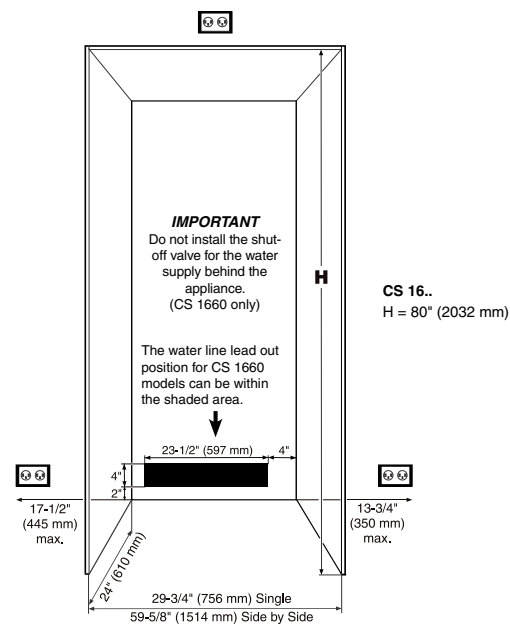

The appliance can be used freestanding or semi built-in. If semi built-in, consider the cabinet opening dimensions.

The power cord comes out of the appliance top. The location of the electrical outlet can be within a radius of 90 inch from the appliance top center.



Liebherr CS 1640B

Freestanding/Semi Built-in



LIEBHERR

Quality, Design and Innovation

Freestanding/Semi Built-in

◀30"▶

The urban design of the **CS 1640B** is the perfect choice for apartment living. The CS 1640B includes smart interior design features like a beverage rack, foldable glass shelf, and a stainless back wall which prevents ice build-up and dripping. Liebherr's SmartSteel material on the door is scratch resistant and makes fingerprints virtually disappear. Liebherr's DuoCooling system for the refrigerator and the freezer provides superior performance and efficiency, as well as advanced food preservation. DuoCooling creates optimal conditions in both the refrigerator and freezer compartments, which lengthens the shelf life of food items for a healthier lifestyle. Advantageously, this model eliminates the need for a water hook up as it has a convenient 50oz internal water tank for the IceMaker. Simply fill the tank with filtered water to produce perfect half-moon crescent ice cubes.



Freestanding/Semi Built-in

Energy consumption

in 365 days kWh
Estimated Yearly Energy Cost in US \$

Capacity

Total capacity cu.ft. (l)
Refrigerator comp. cu.ft. (l)
NoFrost Freezer comp. cu.ft. (l)

Shipping weight lbs. (kg)

Climate rating

Sound rating dB(A)

Ice cube output lbs. (kg) / 24h

Ice cube stock lbs. (kg)

Door hinges

Outside dimensions

in inches (cm) H/W/D

Cut out dimensions

in inches (cm) H /W/D

Energy supply

Voltage V/Hz

CS 1640B Comfort



496

60*

15.9 (452)

11.6 (331)

4.3 (121)

266.8 (121)

SN-T

40**

3.1 (1.4)

4.4 (2.0)

right, reversible

79 9/16"/29 9/16"/24 13/16" (202/75/63)

80"/29 3/4"/24" (203.2/75.6/61)

115/60

* Energy Cost will depend on utility rates and use. Estimated energy cost based on a national average electricity cost of 12 cents per kWh.

** Noise output – according to EN 60704-3

Features

◀30"▶



German Engineering: Our superior products offer premium quality, cutting edge design and innovative features that fit your busy lifestyle. Exclusive components and materials, along with the latest production processes, ensure energy efficiency and performance for years to come.



SuperCool/SuperFrost: Simply quick chill and/or freeze fresh groceries to preserve optimum freshness and seal in flavors, textures as well as maintain essential vitamins and minerals.



SmartSteel: Available on select freestanding/semi built-in models, SmartSteel significantly reduces the visibility of fingerprints and is very easy to clean and scratch resistant. All that is required to maintain this beautiful exterior is the wipe of a clean dry or damp cloth.



Energy Star: Liebherr refrigerators help produce less energy waste and greenhouse gas emissions with the goal of having the least damaging effect on the environment, while offering solutions that help consumers conserve energy.

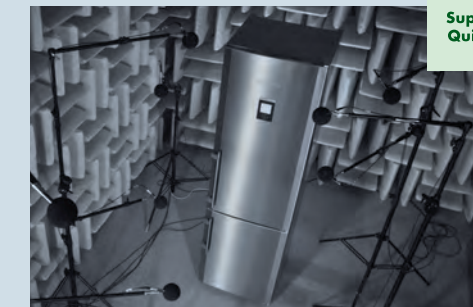

SuperQuiet: Noise is kept to a minimum with virtually silent, speed controlled compressors and a low-noise cooling circuit; while also ensuring exact performance, energy efficiency and SuperQuiet operation.



Stainless back wall: The high-quality, stainless back wall is both eye-catching and highly functional. The stainless wall prevents foods from freezing up against the evaporator, ensuring that the back of the refrigerator is always drip and ice-free. Ventilation slits also help guarantee optimum temperature distribution.



DuoCooling: The dual refrigeration system creates optimal conditions in both the refrigerator and freezer which lengthens the shelf life of food items for a healthier lifestyle. This technology also preserves the flavor and texture of foods since there is no transfer of unwanted air, moisture or food aroma between the two compartments.



SoftSystem: Unique to Liebherr is our patented SoftSystem, often used in high-end cabinetry, ensures that the door closes gently, even when fully loaded. Plus the door opening angle can be reduced to 90 degrees allowing for more design options within kitchen décor.

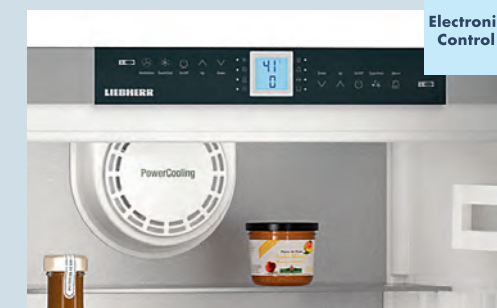

Electronic Display: Our intuitive electronic touch control panel ensures all functions are easy and convenient to use as well as guarantees that the settings selected remain accurate and constant.