

Combination Steam Oven, 24", 9 Function

Series 9 | Minimal

Black



Get more flexibility in the kitchen with both convection cooking and steam cooking, which reduces the need for oils and fats.

- Cooking flexibility with nine oven functions, including five Steam functions, Broil and Convection
- Steam cooking allows you to cook a food in its own juices, to retain nutrients and flavour
- Part of our suite of companion products, designed to match aesthetically for flexible configurations
- 1.3 cu ft total capacity

DIMENSIONS

Height	18 ¹ / ₁₆ "
Width	23 ¹ / ₂ "
Depth	22 ¹ / ₈ "

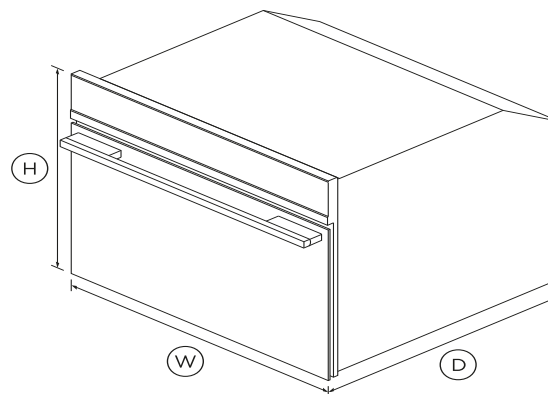

FEATURES & BENEFITS

Sized to suit

This compact 24" Combination Steam Oven can be placed almost anywhere in the kitchen. Companion products share the same dimensions and can be installed in multiple configurations to suit your kitchen design and preference.

Cooking flexibility

The Combination Steam Oven allows ingredients to retain their nutrients, moisture content and coloration. With nine oven modes, it doesn't just steam, but also has Broil and Fan functions.

Easy to use

An easy to use, intuitive display shows the time and provides useful information about functions along with a refill alert.

Beauty of choice

With the choice of a stylish stainless steel or elegant black trim, our Companion products help you achieve a coherent kitchen aesthetic that suits your design style.

Easy cleaning

Cleaning and care of the Combination Steam Oven is simple. After each use, just wipe the smooth stainless steel interior with a dry cloth.

Safe and convenient

The CoolTouch door is safe to touch from the outside, protecting your hands and the surrounding cabinetry. The water tank slides in easily, with no plumbing required.

SKU

81927

TEST The product dimensions and specifications in this page apply to the specific product and model. Under our policy of continuous improvement, these dimensions and specifications may change at any time. You should therefore check with Fisher & Paykel's Customer Care Centre to ensure this page correctly describes the model currently available. ? Fisher & Paykel Appliances Ltd 2020

Other product downloads available at fisherpaykel.com

- [↓](#) User Guide
- [↓](#) Service & Warranty Booklet
- [↓](#) Guide D'Utilisation
- [↓](#) Installation Guide
- [↓](#) Guide D'Installation
- [↓](#) Resources (zip)



A PEACE OF MIND SALE

24 Hours 7 Days a Week Customer Support

T 1.888.936.7872 W www.fisherpaykel.com