

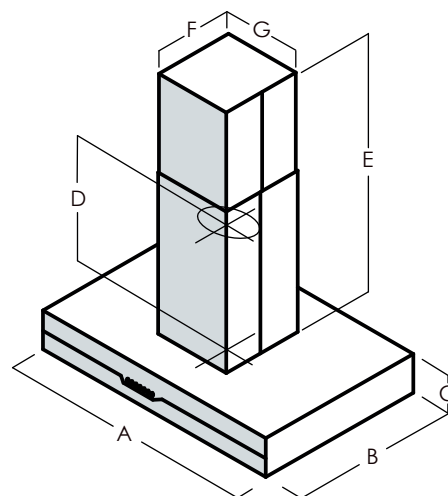

ELICA'S EXCLUSIVE PLUS FEATURES

Black glass and polished stainless steel in its island version, like all of the hoods in the Elica Stream line, also Meteorite is meant for anyone who loves high-technological solutions, where Elica hoods and cooktops, automatically communicate with one another, recognizing quality and quantity of cooking vapors, thus accordingly adjusting performance levels. With Perimeter Aspiration technology helps achieve Top Performance by delivering more powerful and efficient fume extraction plus it reduces noise. Meteorite includes a powerful 550 CFM blower, Strip LED lighting and a tunable white with glass capacitive touch controls.



EMI648SS

A	47 ¹¹ / ₆₄ " (119.8 cm)
B	62 ⁶³ / ₆₄ " (60 cm)
C	2 ²³ / ₆₄ " (6 cm)
D	13 ³ / ₁₆ " (33.5 cm)
E	Min: 28 ¹ / ₃₂ " (71.2 cm) Max: 37 ⁷ / ₈ " (129 cm)
F	12 ¹³ / ₆₄ " (31 cm)
G	12 ¹³ / ₆₄ " (31 cm)



SPECIFICATIONS



	48" UNIT
Model:	EMI648SS
Dimensions:	48" W x 24" D x 28" H
Blower Type(internal):	550 CFM (4-speed)
Blower Performance:	
Speed 1	192 CFM
Speed 2	310 CFM
Speed 3	450 CFM
Speed 4	550 CFM
Noise (sones): Working Speed	Min: 1.7, Max: 7
Finish:	Stainless Steel with Black Glass
Controls:	Touch Control 3 Speeds + Booster (sensor)
Illumination: (replaceable lamps 1 intensity)	Strip LED 7 Watts 2700 - 6000K
Filter Type:	Aluminum Mesh Filter + Perimeter Aspiration
Number of filters:	2
Duct Transition:	Top Round 6"
Installation Type:	Ducted
Electrical:	120 Volts, 60 Hertz, 460 Watt at 3.8 Amp
KITS:	
Optional Recirculating Kit	KIT0120949
CONSUMABLE PARTS:	
Charcoal Filter Replacement:	KIT0121493
Grease Filter Replacement:	GRI0120150A

*Consumable parts are sold in units of one (1). Order accordingly

PLUS FEATURES



WIRELESS CONNECTIVITY - Wireless technology allows the transmission of real time information about cooking (active zones, pots, temperature), to your hood. Elica hoods with STREAM technology will process data and function totally automatically.



AMBIENT LIGHT - Elica studies on hood lighting leaves no stone unturned. Here we have thought about products not only able to light the cooktop, but the entire kitchen space. And so the hood is transformed: from a kitchen appliance to a true lighting element. Considering the design of Elica hoods, it is not hard to imagine how this option is quite unique, and represents one extraordinary point of strength for us.



TOUCH CONTROL - Enjoy effortless cooking, and fully control each cooking zone with the tip of a single finger.



PERIMETER ASPIRATION - This technology draws air through a narrowed channel around a face plate, which increases suction, without increasing blower speed or energy consumption.



LONG LIFE FILTER - One of a kind odour filter, capable of regenerating itself and of lasting up to 3 years. To maintain these characteristics, the filter only requires simple maintenance: wash every 2 or 3 months with hot water and mild soap (also in dishwasher at 65 degrees) and dry in the oven for ten minutes at 100 degrees.



TOP PERFORMANCE - Excellent performance for models equipped with this plus. High fume capturing capacity with an average aspiration range of 600 CFM's. with low noise levels, 1.2 - 1.7 sones at working speed.