

## FAB5ULNE

### 50's Retro style

50's Retro Style Mini Refrigerator,  
Black, Left hand hinge

EAN13: 8017709182267

Capacity 1.5 Cu. Ft.

Absorption cooling = ultra low noise level

Automatic defrost

LED Internal light

2 adjustable shelves

Door storage: 1 balcony shelf, 1 bottle shelf

Ice cube tray

Voltage: 115 V

Current: 10Amps

Frequency: 60Hz

Dimensions: (H x W x D) 28 9/64" x 15 57/64" x 22 3/64"

Gross Weight: 65lbs.

Net Weight: 51.2 lbs.



### Versions

---

- **FAB5URNE** - Black, hinges on the right
- **FAB5URO** - Orange, hinges on the right
- **FAB5ULO** - Orange, hinges on the left
- **FAB5URP** - Cream, hinges on the right
- **FAB5ULP** - Cream, hinges on the left
- **FAB5URR** - Red, hinges on the right
- **FAB5ULR** - Red, hinges on the left



## FAB5ULNE

50's Retro style  
fridge  
free standing  
50's style  
black

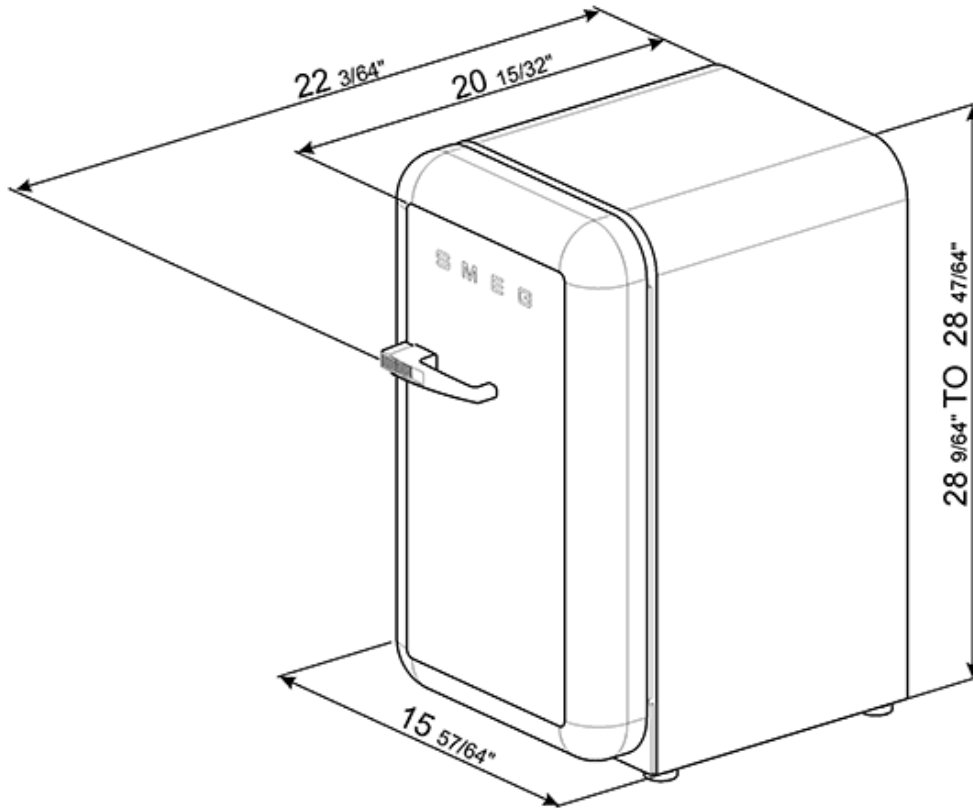

SMEG U.S.A. INC.  
A&D BUILDING  
150 EAST 58th STREET, 7th FLOOR  
NEW YORK, NY, 10155  
Tel. +1 212 265 5378  
Fax +1 212 265 5945