

ASSEMBLY INSTRUCTIONS



aspenhome®

Distributed by Furniture Values International, LLC

ITEM NO: I56-400/403/402 Queen Sleigh LP Bed
 I56-492/403/402 Queen Panel With Mirror LP Bed

COMPONENTS LIST -400/492		HARDWARE PACK For -400/492	
Headboard	1 Pc	A Bolt (Ø5/16"*1-3/4")	8 Pcs
Left Leg	1 Pc	B Bolt (Ø1/4"*2-3/8")	4 Pcs
Right Leg	1 Pc	C Bolt (Ø1/4"*1-9/16")	4 Pcs
Wood Stretcher	1 Pc	D Lock Washer (Ø5/16")	16 Pcs
Center Support Leg	1 Pc	E Flat Washer (Ø5/16"*3/4")	16 Pcs
COMPONENTS LIST -403		F Allen Wrench (4mm)	1 Pc
Footboard	1 Pc	HARDWARE PACK For -402	
Support legs (for slats)	4 Set	G Bolt (Ø5/16"* 4")	8 Pcs
COMPONENTS LIST -402		H Half Moon Washer (Ø5/16")	8 Pcs
Bed rails	2 Pcs	I Lock Washer (Ø5/16")	8 Pcs
Slats	4 Pcs	J Hex Nut (Ø5/16"*1/2")	8 Pcs
		K Hex Wrench	1 Pc
		L Wood Screw (#8*1-1/4")	8 Pcs
		M Allen Wrench (4mm)	1 Pc

SAFETY WARNING:

ALL beds need to be set up in the exact final location so that after full assembly it will not need to be moved. Moving the bed will cause the support legs to move out of the perpendicular (90 degree) and weaken the support system and may allow the bed to collapse.

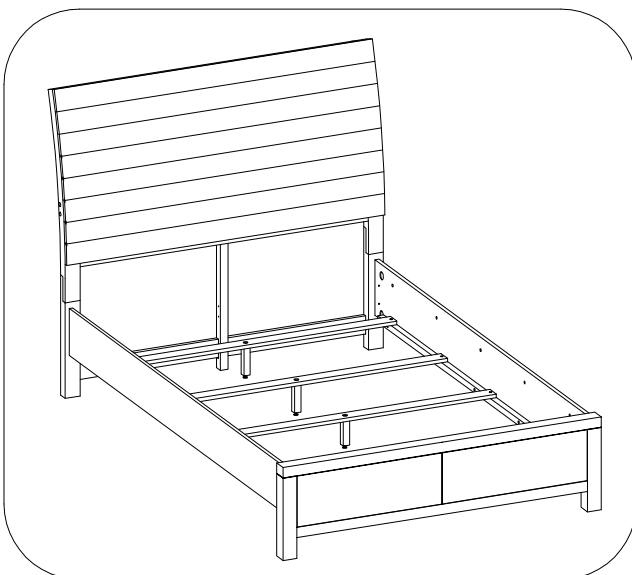

Queen Sleigh LP Bed

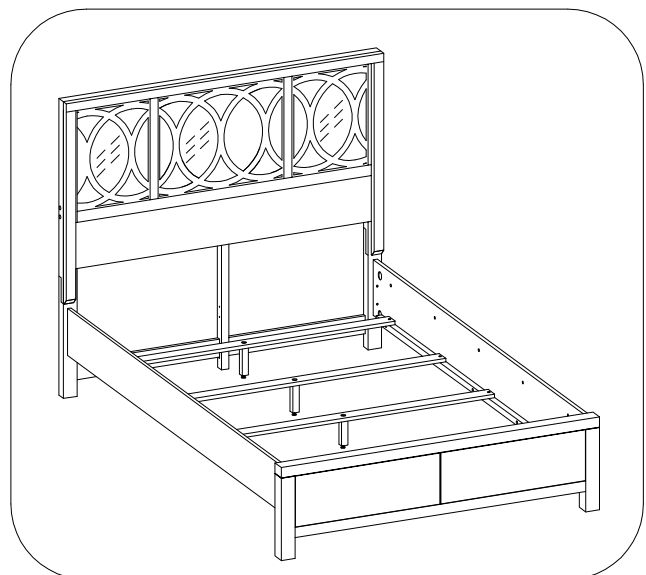

Queen Panel With Mirror LP Bed

ASSEMBLY INSTRUCTIONS



aspenhome®

Distributed by Furniture Values International, LLC

ITEM NO: I56-400/403/402 Queen Sleigh LP Bed
I56-492/403/402 Queen Panel With Mirror LP Bed

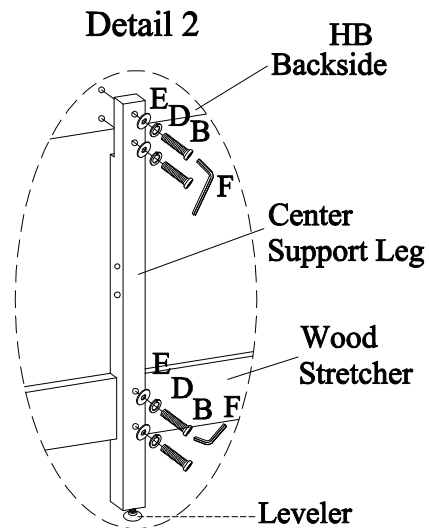
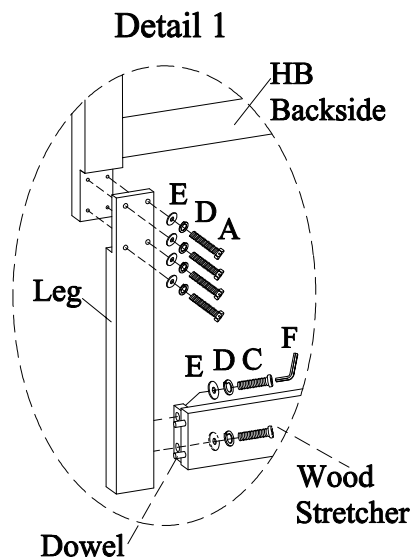
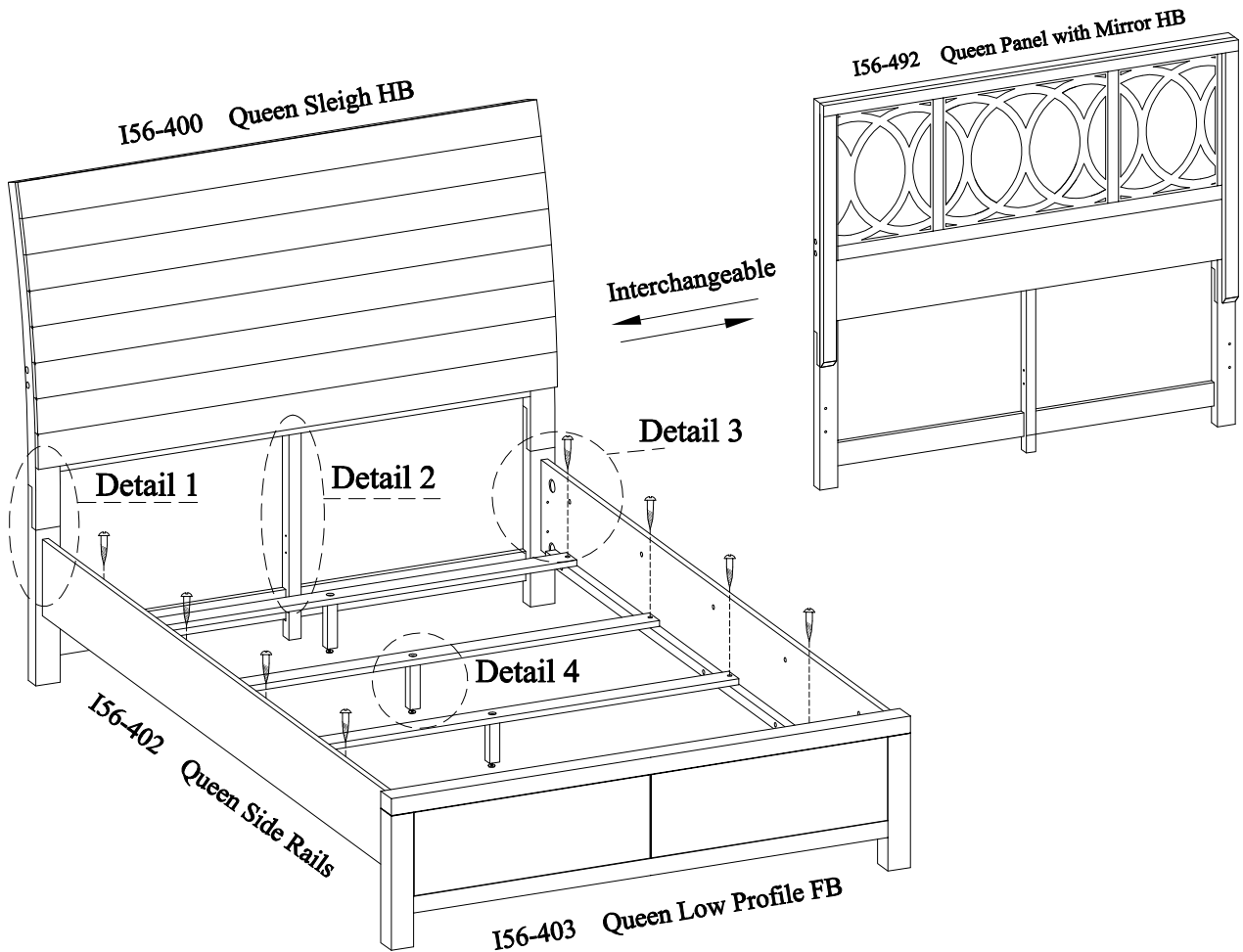

MADE IN VIETNAM



aspenhome®

Distributed by Furniture Values International, LLC

ITEM NO: I56-400/403/402 Queen Sleigh LP Bed
 I56-492/403/402 Queen Panel With Mirror LP Bed

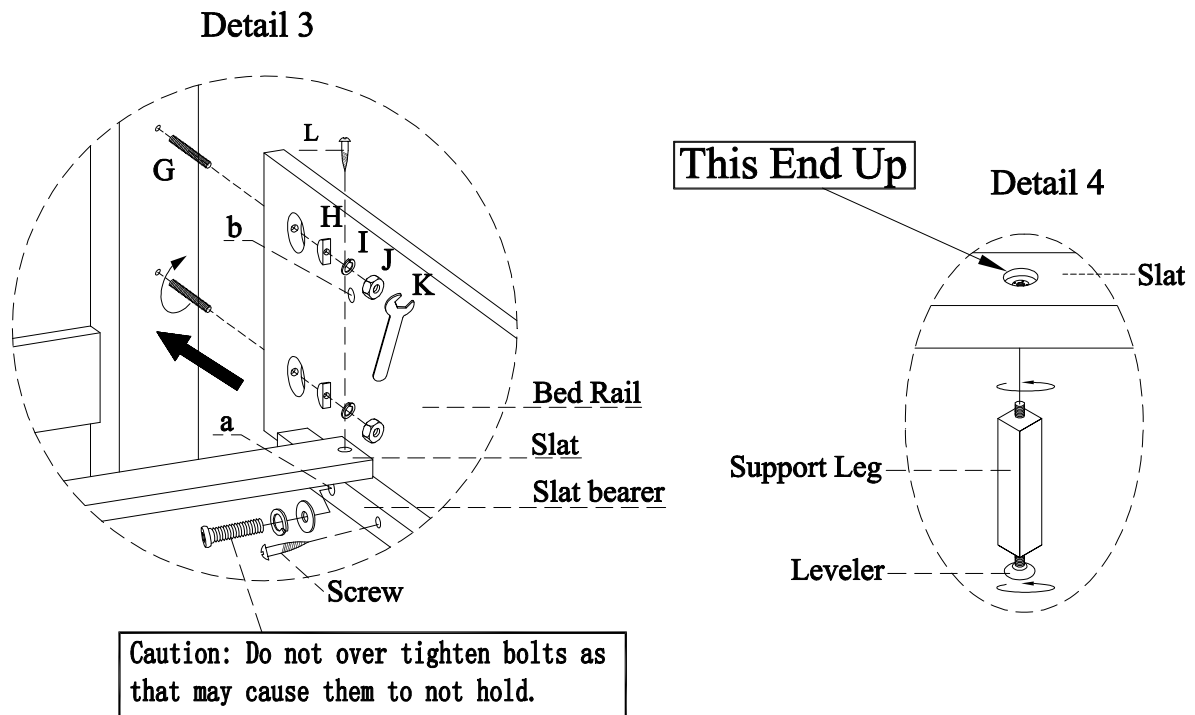

Assembly Steps:

1. Attach legs to headboard using bolts A, and attach wood stretcher to the legs using bolts C as shown in detail 1. Then attach center support leg to the headboard using bolts B and to the wood stretcher using bolts B. See detail 2. Use an Allen Wrench to tighten all the bolts.
2. The slat bearers have been attached in the position b. You have to move your slat bearers in to position a. Remove the bolts (10pcs) and screws (8pcs) from the slat bearers to the side rails. Then re-attach the slat bearers to the side rails with bolts, lock washers, flat washers and screws. See detail 3.
3. Screw the bolts(G) onto HB & FB. Align the bolts with the holes in the end of side rails and attach the side rails to HB & FB using half wood washers(H), lock washers(I) and nuts (J). Then use a hex wrench to tighten all the nuts. See detail 3.
4. Assemble the support legs with leveler to the slats as shown in detail 4, and attach the slats to the slat bearer equally with wood screws (L), as shown in detail 3. Adjust the levelers on bottom of support legs when necessary.

ASSEMBLY INSTRUCTIONS



aspenhome

Distributed by Furniture Values International, LLC

ITEM NO: I56-400/403D/402 Queen Sleigh Storage Bed
 I56-492/403D/402 Queen Panel With Mirror Storage Bed

COMPONENTS LIST -400/492		HARDWARE PACK For -400/492	
Headboard	1 Pc	A Bolt (Ø5/16"*1-3/4")	8 Pcs
Left Leg	1 Pc	B Bolt (Ø1/4"*2-3/8")	4 Pcs
Right Leg	1 Pc	C Bolt (Ø1/4"*1-9/16")	4 Pcs
Wood Stretcher	1 Pc	D Lock Washer (Ø5/16")	16 Pcs
Center Support Leg	1 Pc	E Flat Washer (Ø5/16"*3/4")	16 Pcs
HARDWARE PACK For -402		F Allen Wrench (4mm)	1 Pc
COMPONENTS LIST -402		HARDWARE PACK For -402	
Bed rails	2 Pcs	G Bolt (Ø5/16"* 4")	8 Pcs
Slats	4 Pcs	H Half Moon Washer (Ø5/16")	8 Pcs
COMPONENTS LIST -403D		I Lock Washer (Ø5/16)	8 Pcs
Footboard	1 Pc	J Hex Nut (Ø5/16"*1/2")	8 Pcs
Support legs (for center rail)	2 Pcs	K Hex Wrench	1 Pc
Support leg (for pedestal)	2 Pcs	L Wood Screw (#8*1-1/4")	8 Pcs
Decking	4 Pcs	M Allen Wrench (4mm)	1 Pc
Center Rail	1 Pc	HARDWARE PACK For -403D	
		N Bolt (Ø1/4"*1-1/4")	4 Pcs
		O Bolt (Ø1/4"*1-9/16")	8 Pcs
		P Lock Washer (Ø5/16")	12 Pcs
		Q Flat Washer (Ø5/16"*3/4")	12 Pcs
		R Wood Screw (#8*3/4")	8 Pcs
		S Allen Wrench (4 mm)	1 Pc

SAFETY WARNING:

ALL beds need to be set up in the exact final location so that after full assembly it will not need to be moved. Moving the bed will cause the support legs to move out of the perpendicular (90 degree) and weaken the support system and may allow the bed to collapse.

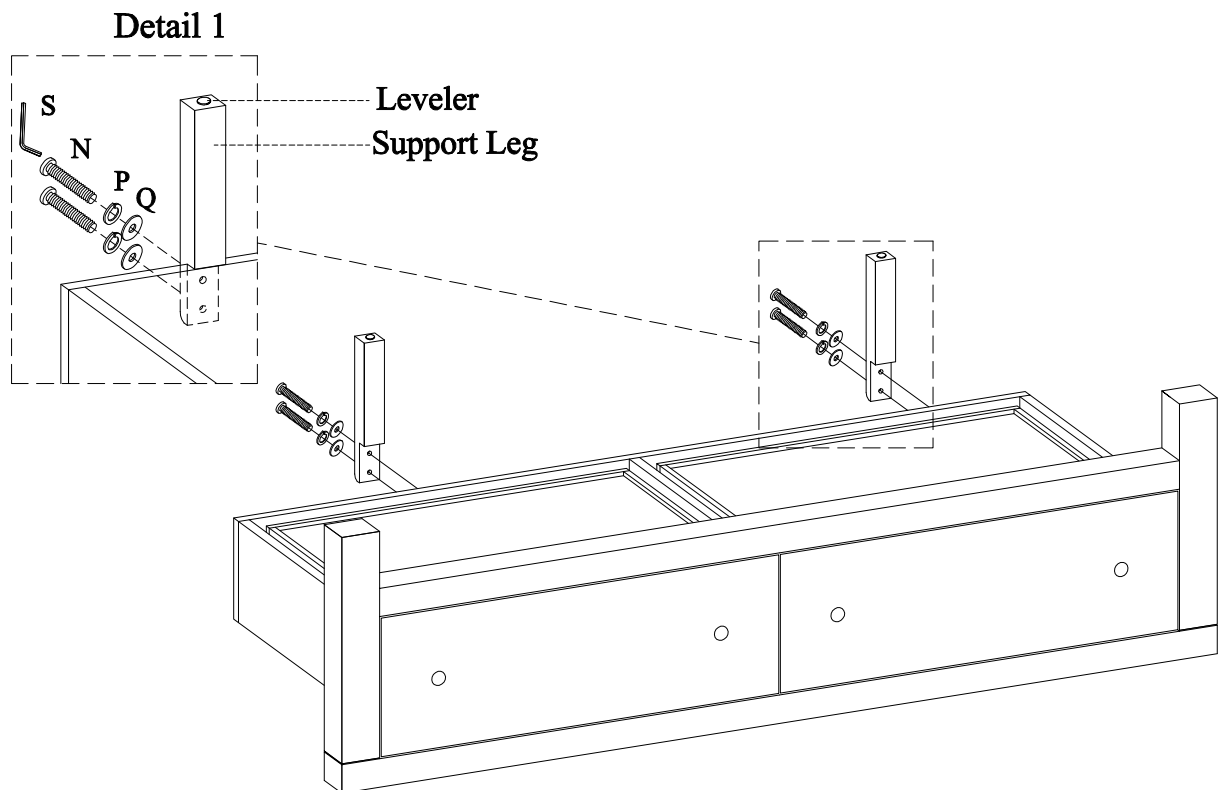

ASSEMBLY INSTRUCTIONS



aspenhome®

Distributed by Furniture Values International, LLC

ITEM NO: I56-400/403D/402 Queen Sleigh Storage Bed
I56-492/403D/402 Queen Panel With Mirror Storage Bed

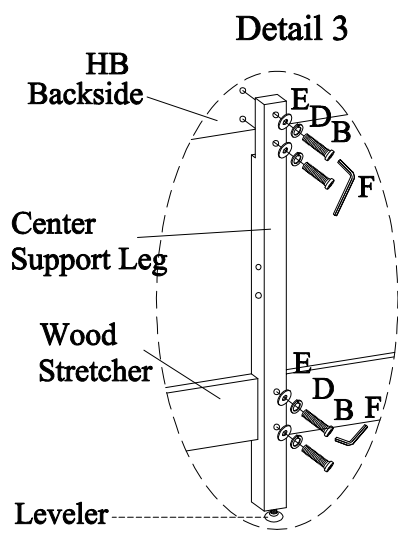
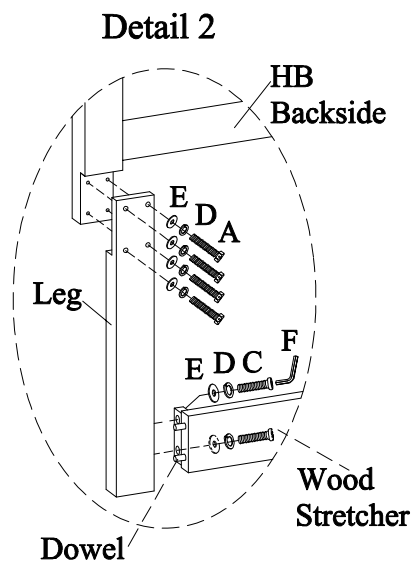
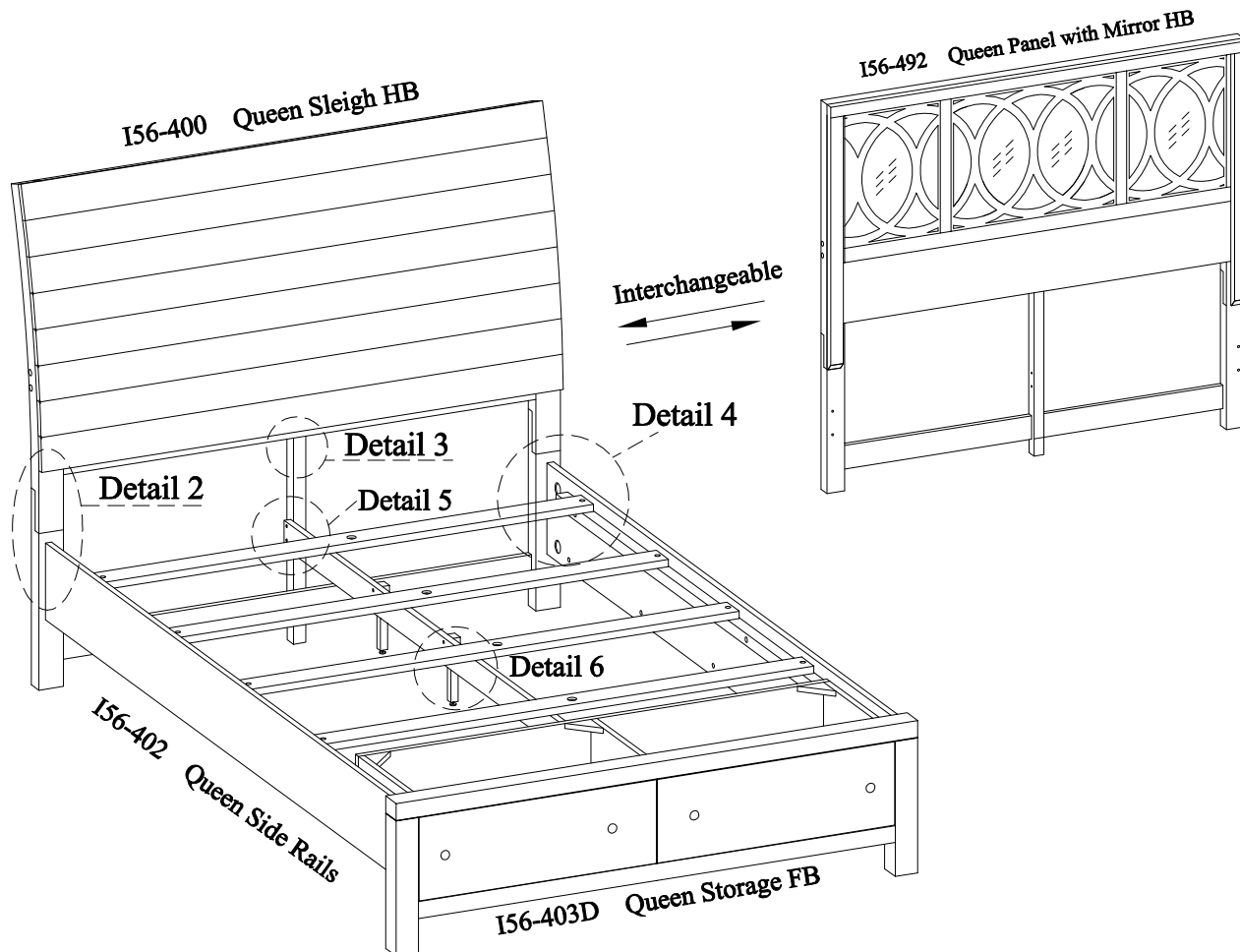

MADE IN VIETNAM

ASSEMBLY INSTRUCTIONS

ah

aspenhome®

Distributed by Furniture Values International, LLC

ITEM NO: I56-400/403D/402 Queen Sleigh Storage Bed
I56-492/403D/402 Queen Panel With Mirror Storage Bed

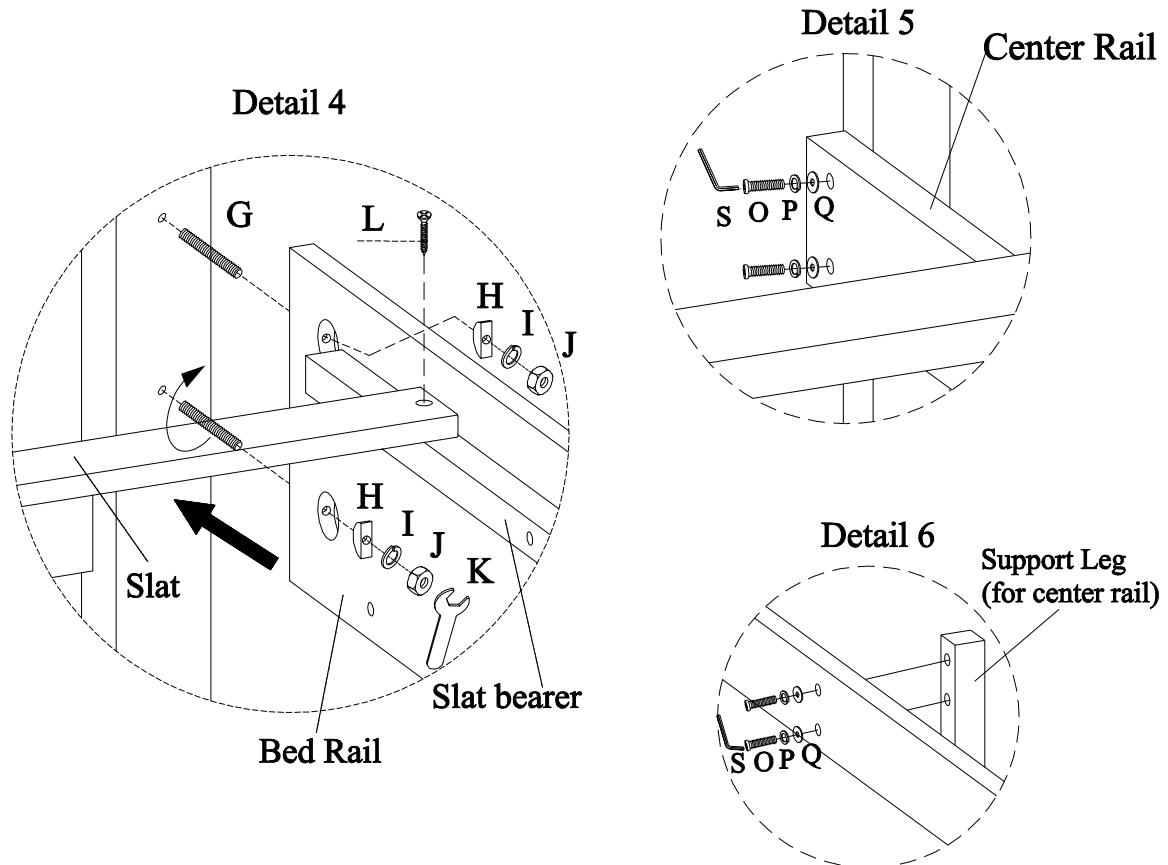

Assembly Steps:

1. Assemble support legs (for pedestal) to footboard. See detail 1.
2. Attach legs to headboard using bolts A, and attach wood stretcher to the legs using bolts C as shown in detail 2. Then attach center support leg to the headboard using bolts B and to the wood stretcher using bolts B. See detail 3. Use an Allen Wrench to tighten all the bolts.
3. Screw the bolts(G) onto HB & FB. Align the bolts with the holes in the end of side rails and attach the side rails to HB & FB using half woon washers(H),lock washers(I) and nuts (J).Then use a hex wrench to tighten all the nuts.See detail 4.
4. Assemble center rail to the headboard center support leg and footboard using 4 bolts O, see detail 5.
5. Assemble 2 support legs (for center rail) to the center rail using 4 bolts O, see detail 6.
6. Locate the slats on the slat bearers with proper distance. Then attach the slats to the slat bearers with wood screws (L), as shown in detail 4.
7. Adjust the levelers on bottom of support legs when necessary.
8. Put the decking on the bed, secure decking to the slats with wood screws (R) through the pre-drilled holes in the decking as shown next page.

MADE IN VIETNAM

ASSEMBLY INSTRUCTIONS

ah

aspenhome®

Distributed by Furniture Values International, LLC

ITEM NO: I56-400/403D/402 Queen Sleigh Storage Bed
I56-492/403D/402 Queen Panel With Mirror Storage Bed

The slat should support both pieces of decking.

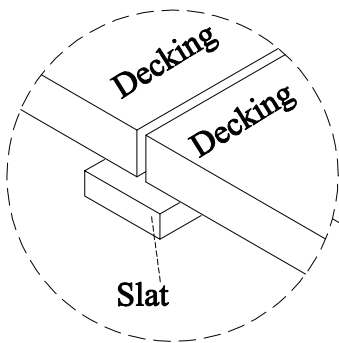

Queen Sleigh Storage Bed

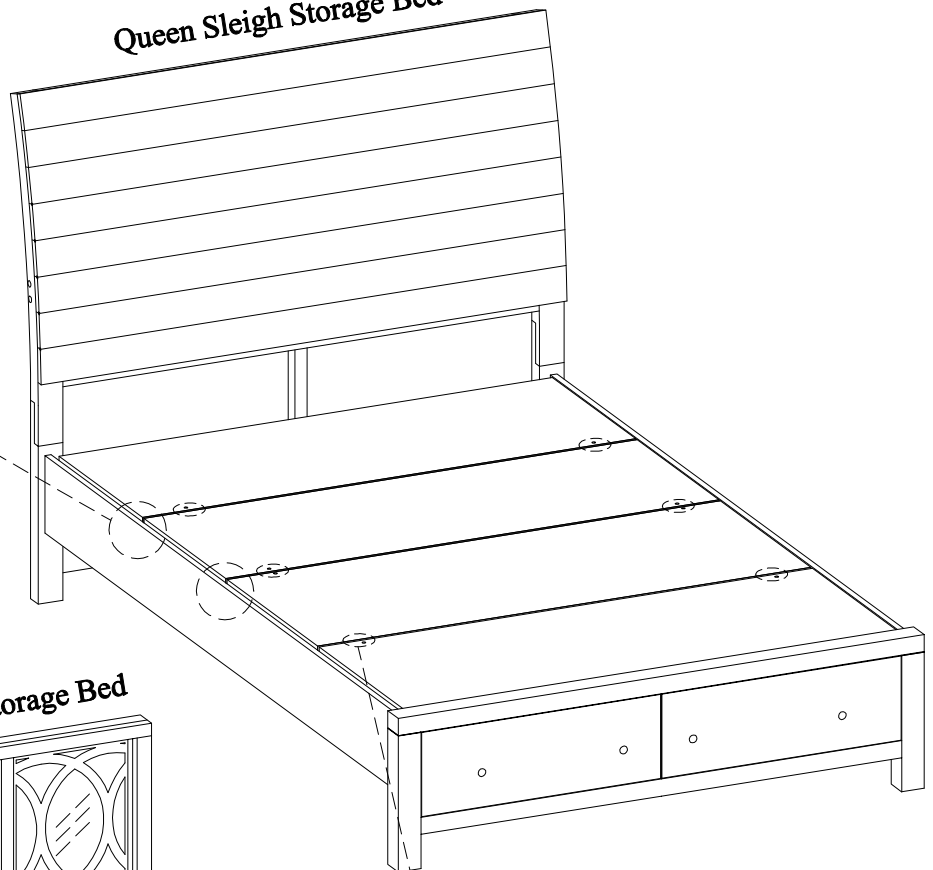

Queen Panel With Mirror Storage Bed

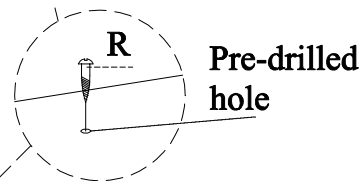
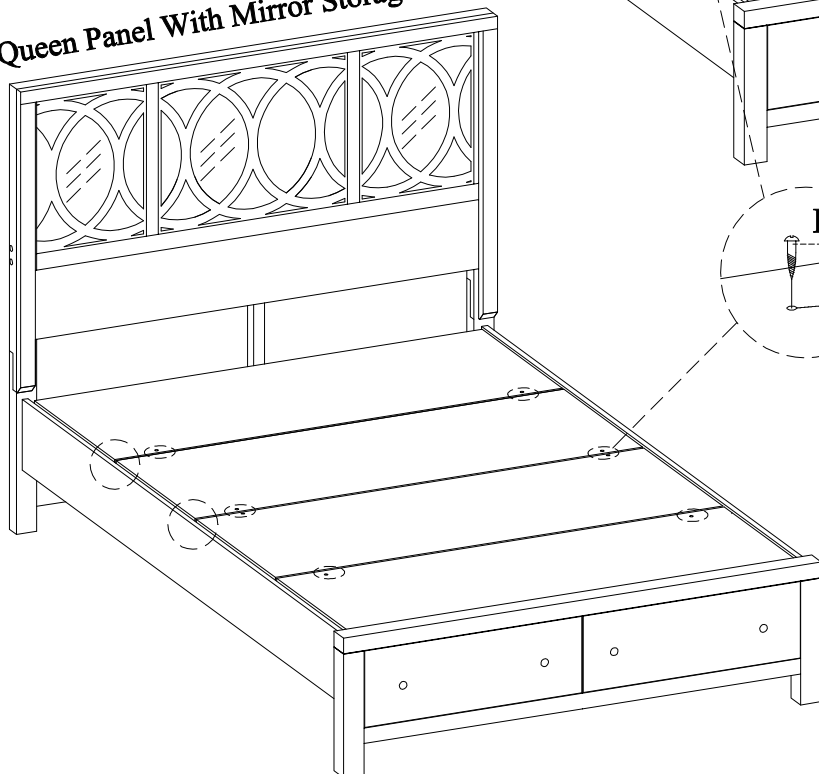

Make sure that there is a slat under the pre-drilled hole.

ASSEMBLY INSTRUCTIONS



aspenhome[®]

Distributed by Furniture Values International, LLC

ITEM NO: I56-404/407/406 & 404/407/410 King/Cal King Sleigh LP Bed
 I56-495/407/406 & 495/407/410 King/Cal King Panel With Mirror LP Bed

COMPONENTS LIST -404/495		HARDWARE PACK For -404/495	
Headboard	1 Pc	A Bolt (Ø5/16"*1-3/4")	8 Pcs
Left Leg	1 Pc	B Bolt (Ø1/4"*2-3/8")	4 Pcs
Right Leg	1 Pc	C Bolt (Ø1/4"*1-9/16")	4 Pcs
Wood Stretcher	1 Pc	D Lock Washer (Ø5/16")	16 Pcs
Center Support Leg	1 Pc	E Flat Washer (Ø5/16"*3/4")	16 Pcs
COMPONENTS LIST -407		F Allen Wrench (4mm)	1 Pc
Footboard	1 Pc	HARDWARE PACK For -406/410	
Support legs (for slats)	5 Set	G Bolt (Ø5/16"* 4")	8 Pcs
COMPONENTS LIST -406		H Half Moon Washer (Ø5/16")	8 Pcs
Bed rails	2 Pcs	I Lock Washer (Ø5/16")	8 Pcs
Slats	5 Pcs	J Hex Nut (Ø5/16"*1/2")	8 Pcs
COMPONENTS LIST -410		K Hex Wrench	1 Pc
Bed rails	2 Pcs	L Wood Screw (#8*1-1/4")	10 Pcs
Slats	5 Pcs	M Allen Wrench (4mm)	1 Pc
Center Rail (long)	1 Pc		

SAFETY WARNING:

ALL beds need to be set up in the exact final location so that after full assembly it will not need to be moved. Moving the bed will cause the support legs to move out of the perpendicular (90 degree) and weaken the support system and may allow the bed to collapse.

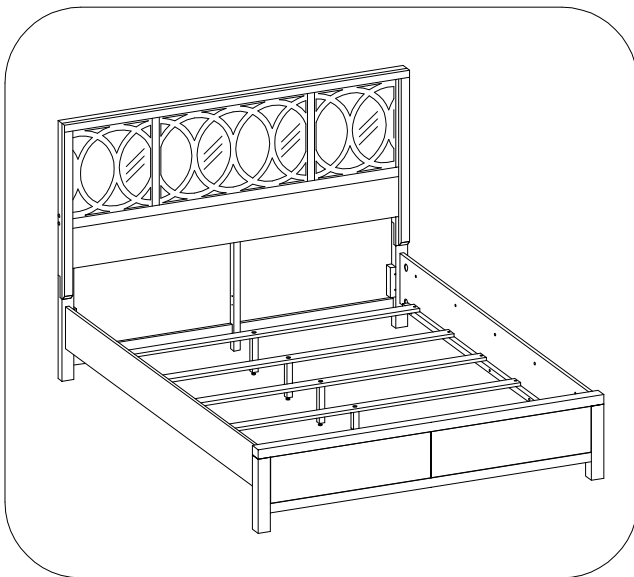

King/Cal King Panel With Mirror LP Bed

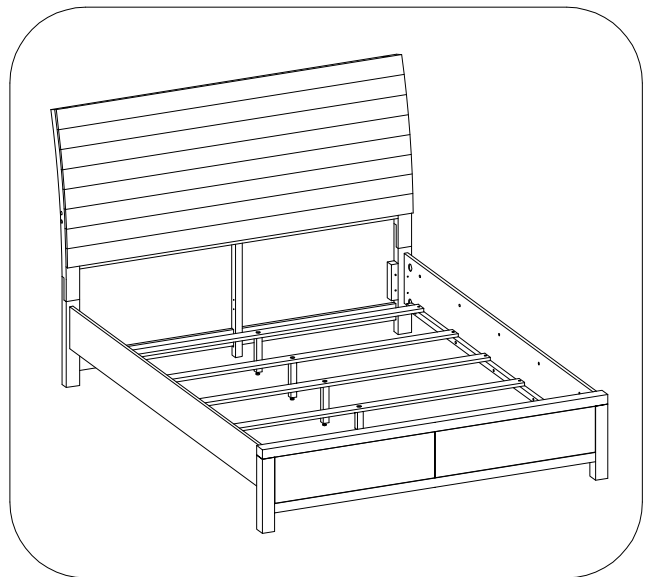

King/Cal King Sleigh LP Bed

ASSEMBLY INSTRUCTIONS



aspenhome®

Distributed by Furniture Values International, LLC

ITEM NO: I56-404/407/406 & 404/407/410 King/Cal King Sleigh LP Bed
I56-495/407/406 & 495/407/410 King/Cal King Panel With Mirror LP Bed

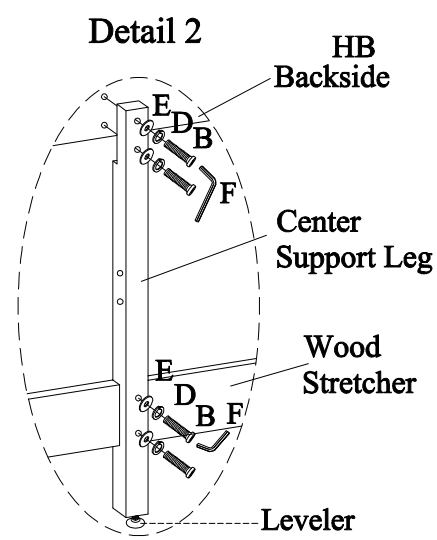
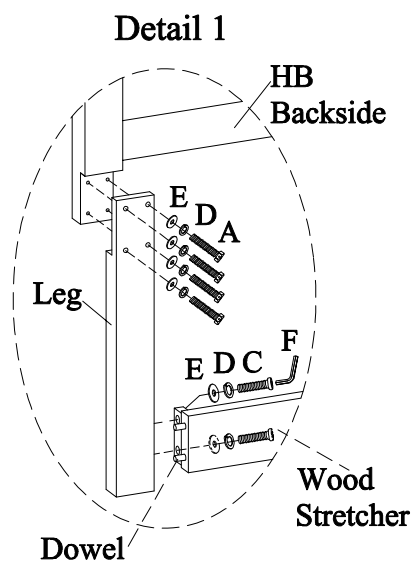
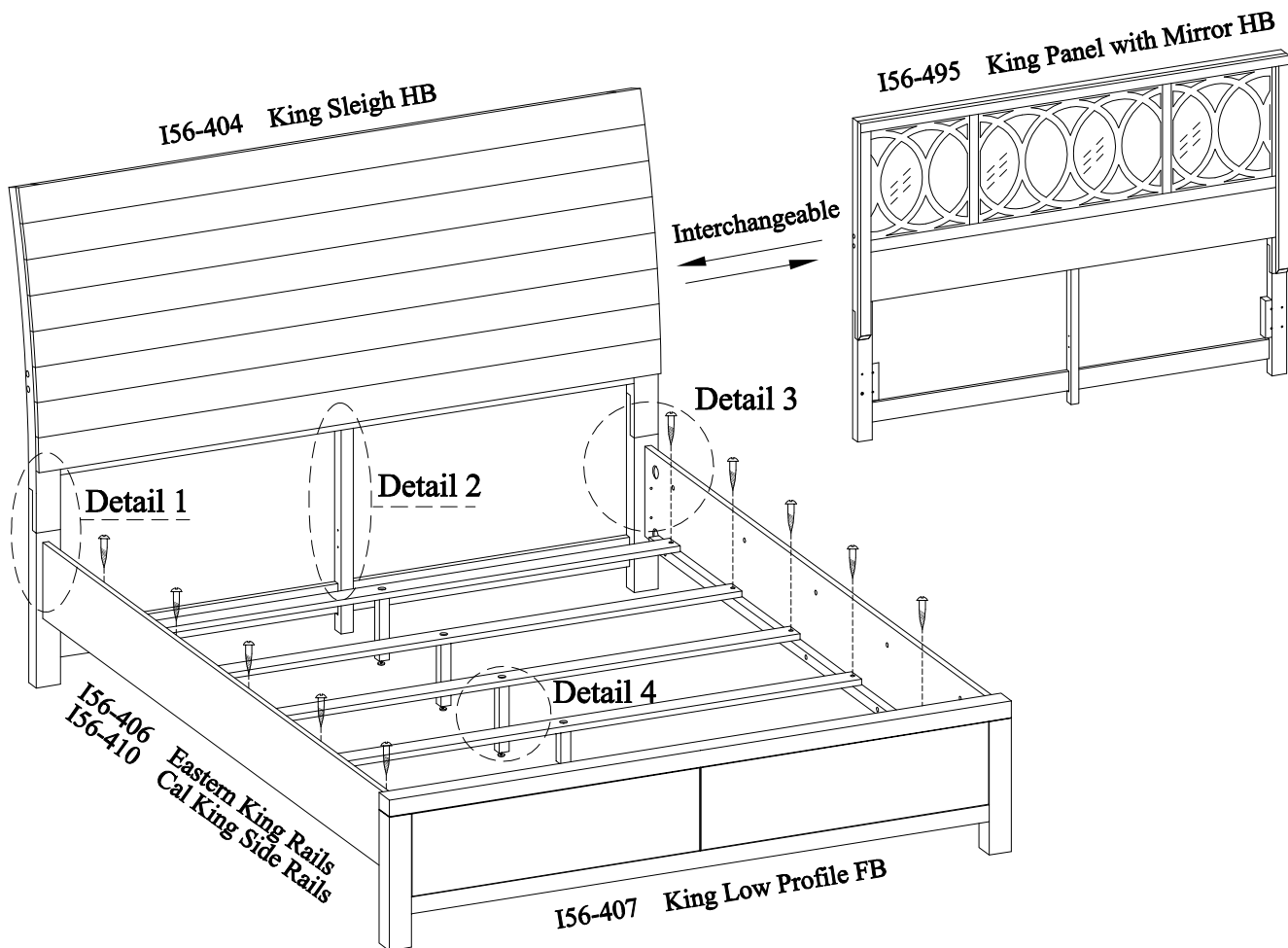

MADE IN VIETNAM

ASSEMBLY INSTRUCTIONS

ah

aspenhome®

Distributed by Furniture Values International, LLC

ITEM NO: I56-404/407/406 & 404/407/410 King/Cal King Sleigh LP Bed
I56-495/407/406 & 495/407/410 King/Cal King Panel With Mirror LP Bed

The outside slots match to 6/6 bed rails,
the inside slots match to 6/0 bed rails.

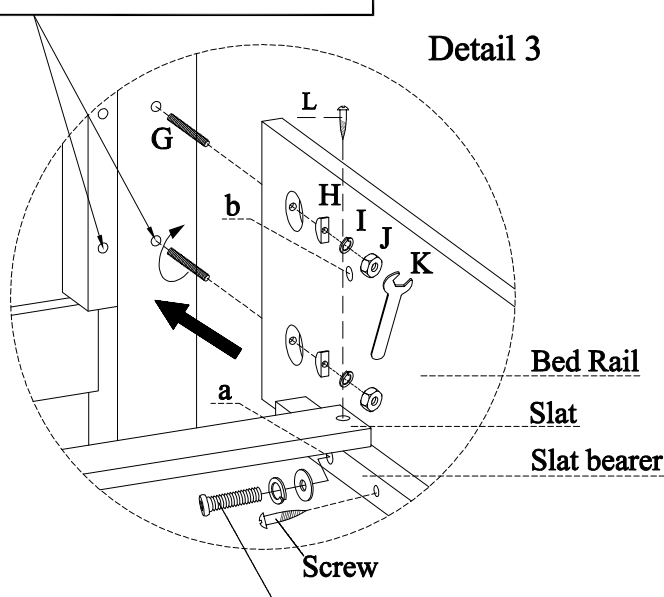

Detail 4

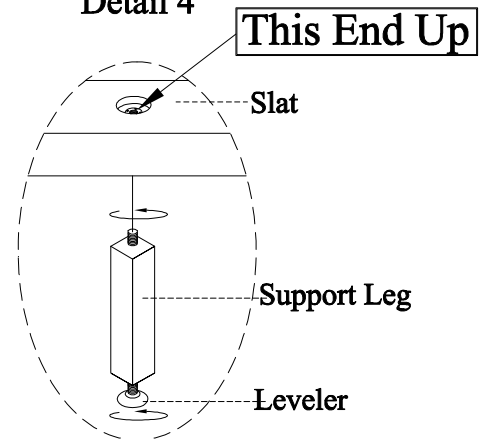

Caution: Do not over tighten bolts as
that may cause them to not hold.

Assembly Steps:

1. Attach legs to headboard using bolts A, and attach wood stretcher to the legs using bolts C as shown in detail 1. Then attach center support leg to the headboard using bolts B and to the wood stretcher using bolts B. See detail 2. Use an Allen Wrench to tighten all the bolts.
2. The slat bearers have been attached in the position b. You have to move your slat bearers in to position a. Remove the bolts (10pcs) and screws (8pcs) from the slat bearers to the side rails. Then re-attach the slat bearers to the side rails with bolts, lock washers, flat washers and screws. See detail 3.
3. Screw the bolts(G) onto HB & FB. Align the bolts with the holes in the end of side rails and attach the side rails to HB & FB using half wood washers(H), lock washers(I) and nuts (J). Then use a hex wrench to tighten all the nuts. See detail 3.
4. Assemble the support legs with leveler to the slats as shown in detail 4, and attach the slats to the slat bearer equally with wood screws (L), as shown in detail 3. Adjust the levelers on bottom of support legs when necessary.

MADE IN VIETNAM

ASSEMBLY INSTRUCTIONS



aspenhome[®]

Distributed by Furniture Values International, LLC

ITEM NO: I56-404/407/406 & 404/407/410 King/Cal King Sleigh Storage Bed
 I56-495/407/406 & 495/407/410 King/Cal King Panel With Mirror Storage Bed

COMPONENTS LIST -404/495		HARDWARE PACK For -404/495	
Headboard	1 Pc	A Bolt (Ø5/16"*1-3/4")	8 Pcs
Left Leg	1 Pc	B Bolt (Ø1/4"*2-3/8")	4 Pcs
Right Leg	1 Pc	C Bolt (Ø1/4"*1-9/16")	4 Pcs
Wood Stretcher	1 Pc	D Lock Washer (Ø5/16")	16 Pcs
Center Support Leg	1 Pc	E Flat Washer (Ø5/16"*3/4")	16 Pcs
COMPONENTS LIST -406		F Allen Wrench (4mm)	1 Pc
Bed rails	2 Pcs	HARDWARE PACK For -407D	
Slats	5 Pcs	N Bolt (Ø1/4"*1-1/4")	4 Pcs
COMPONENTS LIST -410		O Bolt (Ø1/4"*1-9/16")	8 Pcs
Bed rails	2 Pcs	P Lock Washer (Ø5/16")	12 Pcs
Slats	5 Pcs	Q Flat Washer (Ø5/16"*3/4")	12 Pcs
Center Rail (long)	1 Pc	R Wood Screw (#8*3/4")	6 Pcs
COMPONENTS LIST -407D		S Allen Wrench (4 mm)	1 Pc
Footboard	1 Pc	HARDWARE PACK For -406/410	
Support legs (for center rail)	2 Pcs	G Bolt (Ø5/16"* 4")	8 Pcs
Support leg (for pedestal)	2 Pcs	H Half Moon Washer (Ø5/16")	8 Pcs
Decking	3 Pcs	I Lock Washer (Ø5/16")	8 Pcs
Decking (Filler)	2 Pcs	J Hex Nut (Ø5/16"*1/2")	8 Pcs
Center Rail (short)	1 Pc	K Hex Wrench	1 Pc
		L Wood Screw (#8*1-1/4")	10 Pcs
		M Allen Wrench (4mm)	1 Pc

SAFETY WARNING:

ALL beds need to be set up in the exact final location so that after full assembly it will not need to be moved. Moving the bed will cause the support legs to move out of the perpendicular (90 degree) and weaken the support system and may allow the bed to collapse.

Detail 1

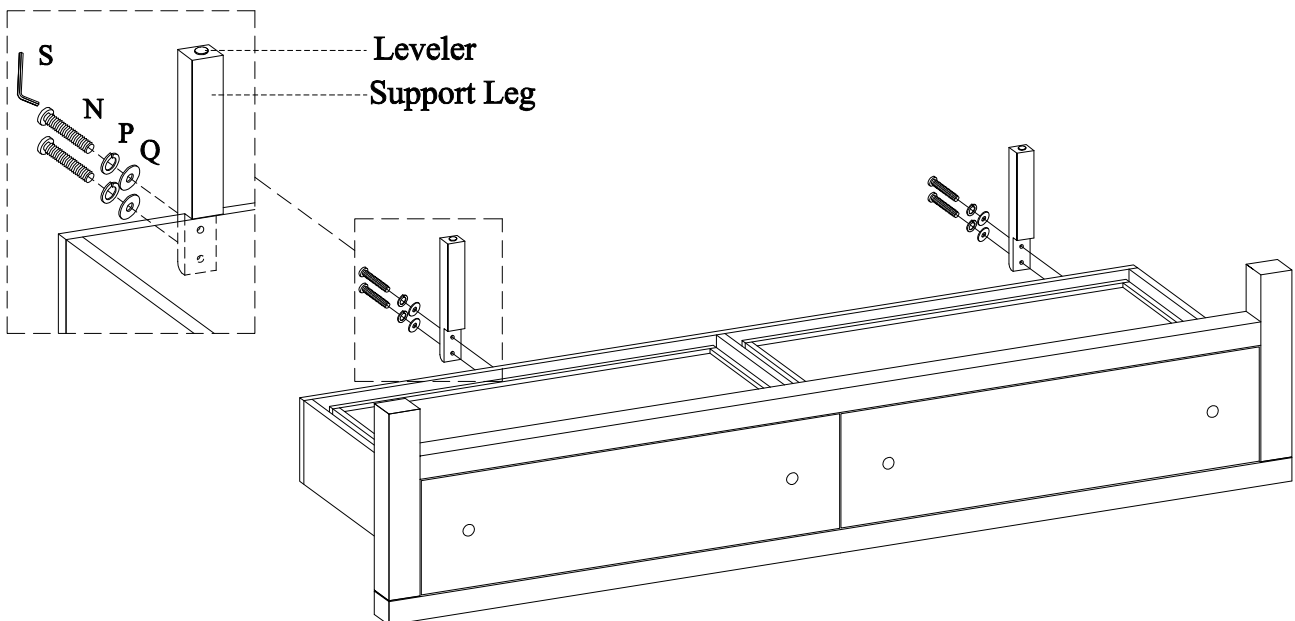

ASSEMBLY INSTRUCTIONS



aspenhome®

Distributed by Furniture Values International, LLC

ITEM NO: I56-404/407/406 & 404/407/410 King/Cal King Sleigh Storage Bed
I56-495/407/406 & 495/407/410 King/Cal King Panel With Mirror Storage Bed

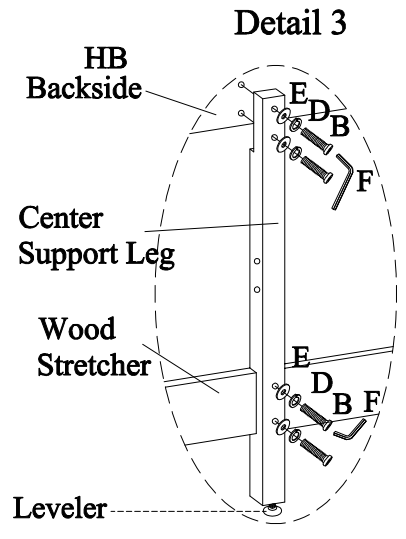
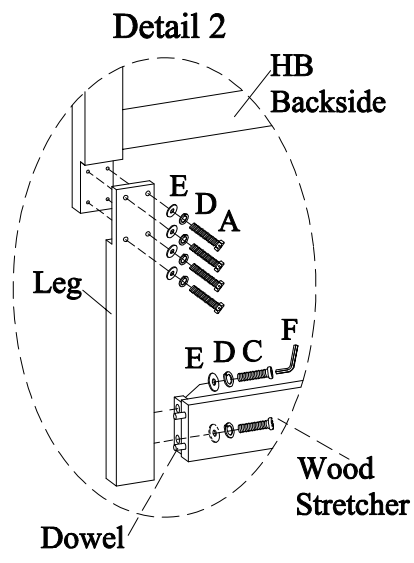
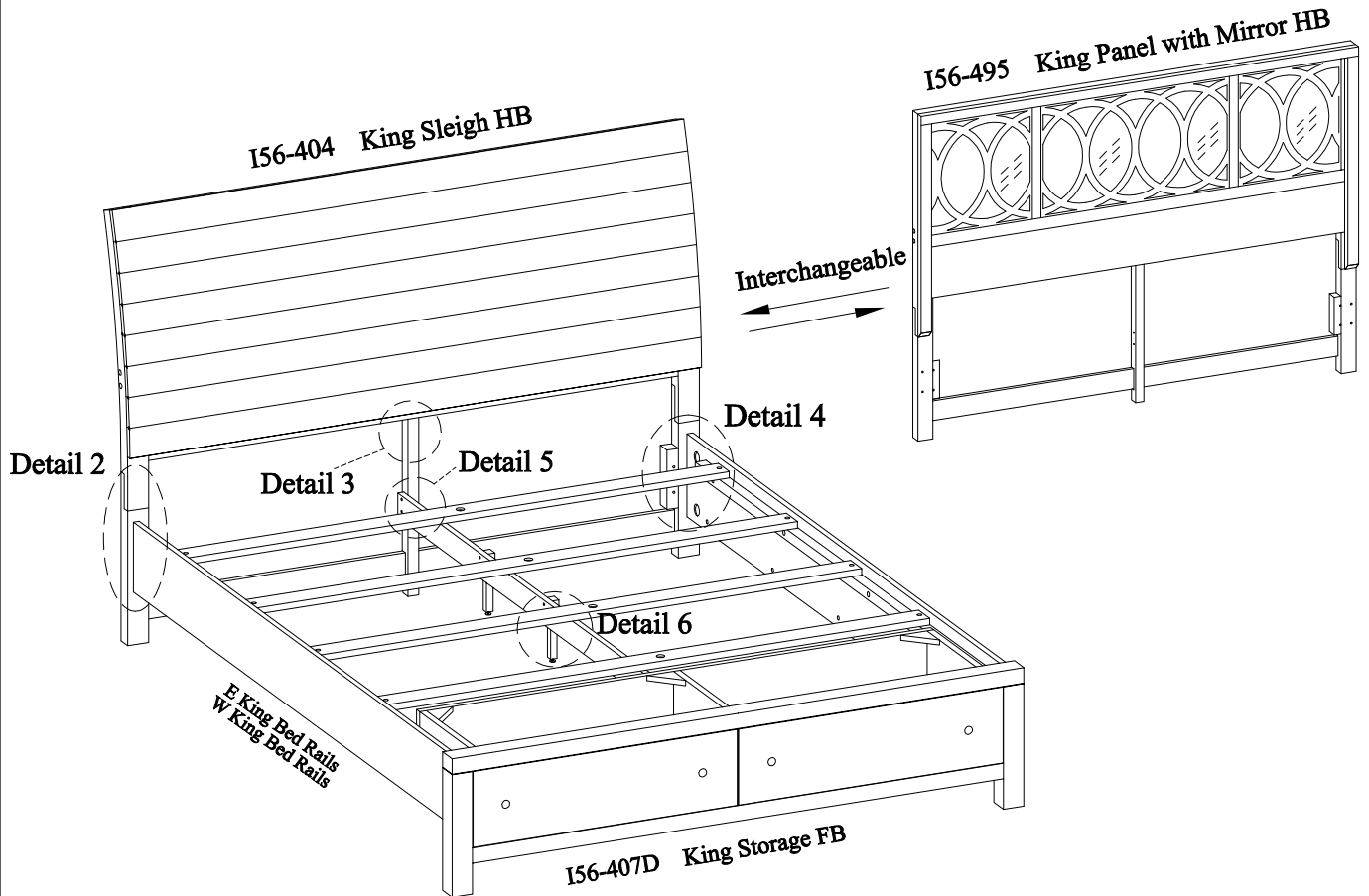

MADE IN VIETNAM

ah

aspenhome®

Distributed by Furniture Values International, LLC

ITEM NO: I56-404/407/406 & 404/407/410 King/Cal King Sleigh Storage Bed
 I56-495/407/406 & 495/407/410 King/Cal King Panel With Mirror Storage Bed

The outside slots match to 6/6 bed rails,
 the inside slots match to 6/0 bed rails.

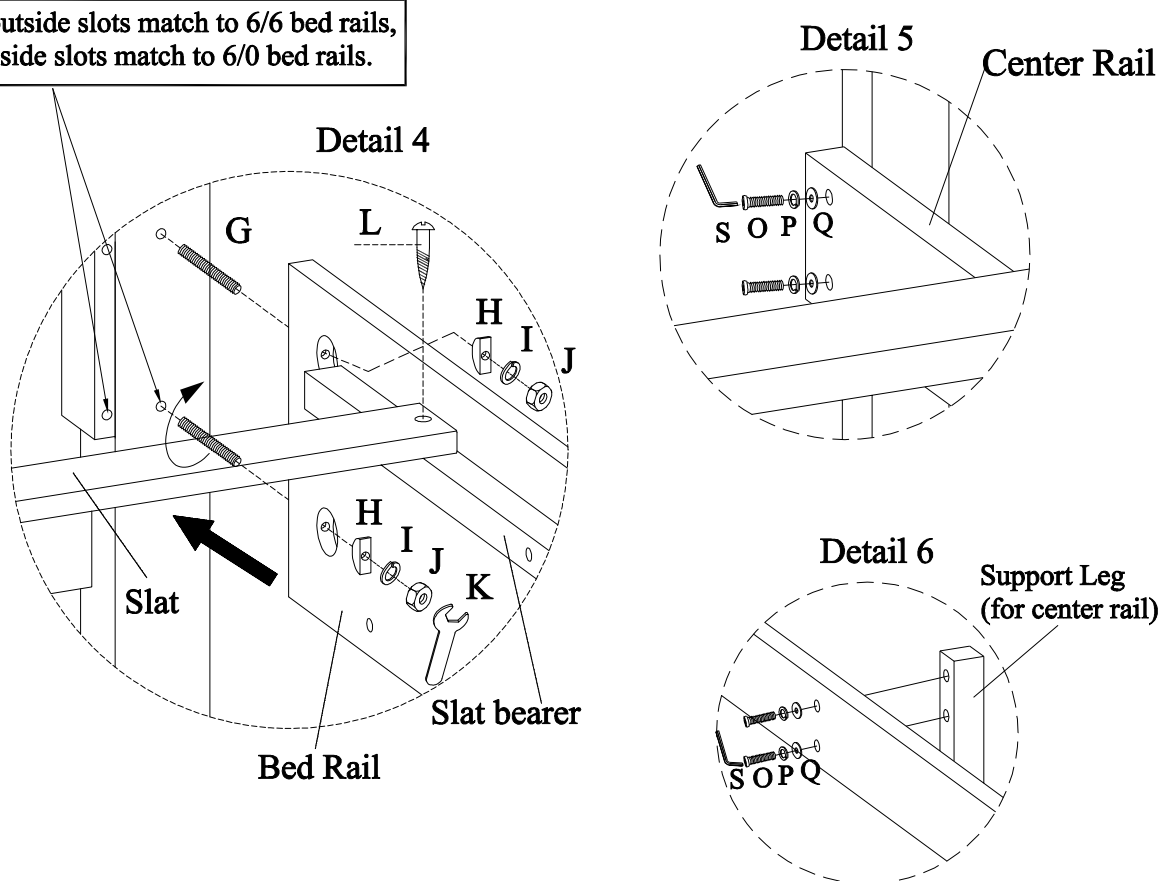

Assembly Steps:

1. Assemble support legs (for pedestal) to footboard. See detail 1.
2. Attach legs to headboard using bolts A, and attach wood stretcher to the legs using bolts C as shown in detail 2. Then attach center support leg to the headboard and to the wood stretcher using bolts B. See detail 3. Use an Allen Wrench to tighten all the bolts.
3. Screw the bolts(G) onto HB & FB. Align the bolts with the holes in the end of side rails and attach the side rails to HB & FB using half wood washers(H), lock washers(I) and nuts (J). Then use a hex wrench to tighten all the nuts. See detail 4.
4. Assemble center rail to the headboard center support leg and footboard using bolts O, see detail 5.
5. Assemble 2 support legs (for center rail) to the center rail using bolts O, see detail 6.
6. Locate the slats on the slat bearers with proper distance. Then attach the slats to the slat bearers with wood screws L, as shown in detail 4.
7. Adjust the levelers on bottom of support legs when necessary.
8. Put the decking on the bed, secure decking to the slats with wood screws (R) through the pre-drilled holes in the decking as shown next page. When the filler is used in 6/0 Cal King bed, please use a utility knife to cut off the small piece and discard from the notch.

ASSEMBLY INSTRUCTIONS

ah

aspenshome®

Distributed by Furniture Values International, LLC

ITEM NO: I56-404/407/406 & 404/407/410 King/Cal King Sleigh Storage Bed
I56-495/407/406 & 495/407/410 King/Cal King Panel With Mirror Storage Bed

