

Item#	Qty	Description	MATERIAL
1	2	TOP ASSEMBLY	WOOD
2	5	DRAWER ASSEMBLY	WOOD/METAL
3	10	FELT PAD	FABRIC
4	5	RIGHT CABINET GLIDE	METAL, PLASTIC
5	5	LEFT CABINET GLIDE	METAL, PLASTIC
6	1	**MITERED BASESTRIP**	WOOD
7	1	**BOTTOM MOULDING**	WOOD
8	2	SIDE BASESTRIP	WOOD
9	1	TIPPING RESTRAINT	PLASTIC
10	10	KNOB	METAL
11	1	**BASESTRIP ASSEMBLY**	WOOD

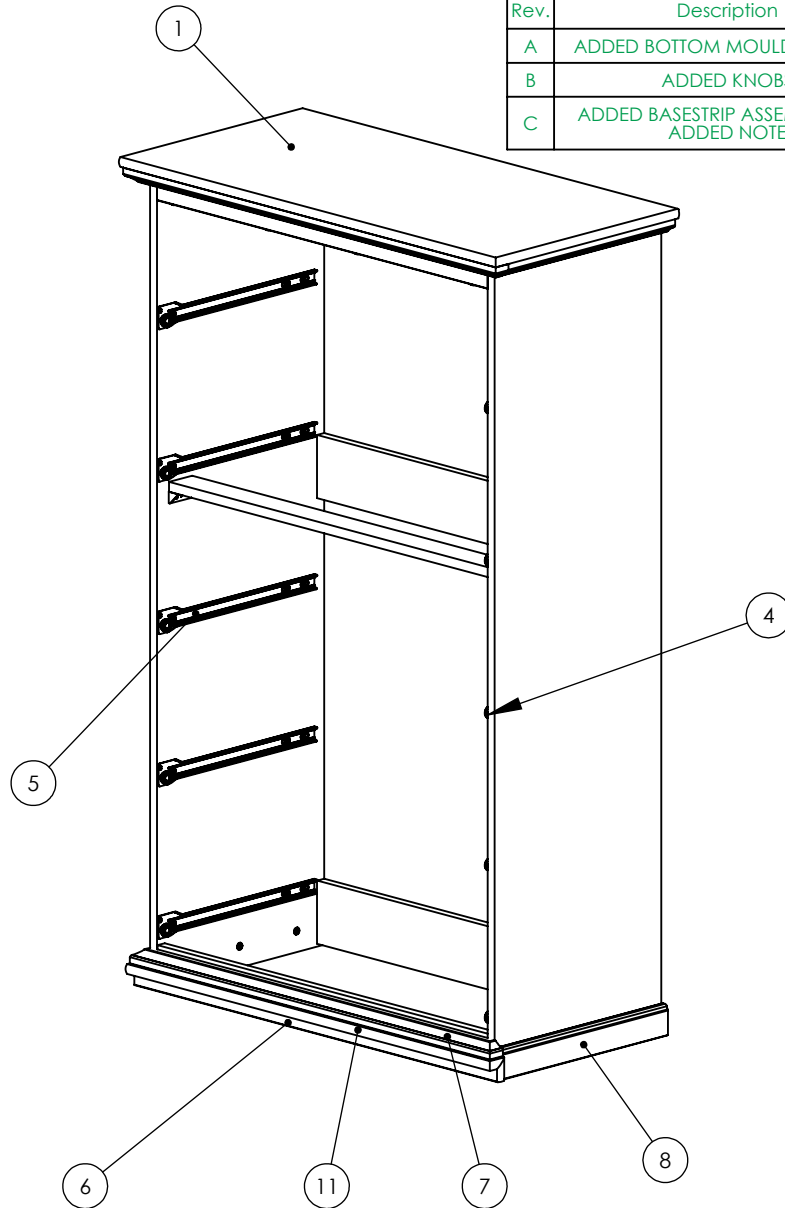

Dwg#: 33874			
Scale: 1:12	TOLERANCES ARE: METRIC:..... +.5 / -.5mm DECIMAL:..... 0 / -.005" FRACTIONAL:..... +0 / -1/32" (UNLESS OTHERWISE SPECIFIED)		
Date: 5/6/2011	Desc: Chest		
Rev.	Description	Date	Cad/Eng
A	ADDED BOTTOM MOULDING NOTE	12/23/2013	BJB
B	ADDED KNOBS	2/10/2016	TH
C	ADDED BASESTRIP ASSEMBLY AND ADDED NOTE	10/10/2016	TH/DK

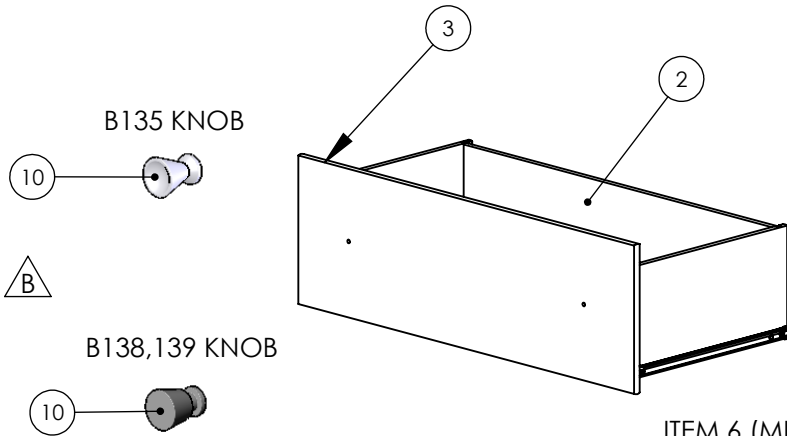

ITEM 6 (MITERED BASESTRIP)
REPLACED BY
ITEM 11 (BASESTRIP ASSEMBLY)



ITEM 7 (BOTTOM MOULDING)
REPLACED BY
ITEM 11 (BASESTRIP ASSEMBLY)