

USE & CARE GUIDE

GUIDE

D'UTILISATION  
ET D'ENTRETIEN

MANUAL DE USO  
Y CUIDADO

Model/Modele/Modelo

T18IF900SP

T24IF900SP















T30IF900SP

T36IF900SP

Freezer

***Thermador***<sup>®</sup>

# en Table of Contents

 <b>Important safety instructions</b> .....	<b>3</b>	 <b>Alarm</b> .....	<b>13</b>
Definitions .....	3	Door alarm .....	13
About these instructions .....	3	 <b>Freezer compartment</b> .....	<b>13</b>
Introduction .....	3	Fully utilizing the freezer volume.....	13
Explosion hazard.....	3	Purchasing frozen food.....	13
Risk of electric shock .....	3	When loading products .....	14
Risk of cold burns.....	3	Freezing fresh food.....	14
Risk of injury .....	4	Thawing frozen food.....	14
Danger due to refrigerants .....	4	 <b>Defrosting</b> .....	<b>15</b>
Avoiding risks for children: .....	4	Freezer compartment .....	15
Damage .....	4	 <b>Cleaning</b> .....	<b>15</b>
Weight.....	4	 <b>Noises</b> .....	<b>15</b>
State of California Proposition 65 Warnings .....	4	Normal noises .....	15
 <b>Intended use</b> .....	<b>4</b>	Preventing noises .....	15
 <b>Environmental protection</b> .....	<b>4</b>	 <b>Lighting</b> .....	<b>15</b>
Packaging .....	4	 <b>Faults – what to do?</b> .....	<b>16</b>
Old appliances .....	5	Appliance .....	16
 <b>Installation and connection</b> .....	<b>5</b>	Ice maker .....	16
Scope of supply .....	5	 <b>Customer service</b> .....	<b>17</b>
Technical data.....	5	Appliance self-test .....	17
Installing the appliance .....	5	Repair order and advice on faults .....	17
Built-in cut-out .....	5		
Side-by-side installation.....	5		
Saving energy.....	6		
Before using for the first time .....	7		
Water connection .....	7		
Electrical connection.....	7		
 <b>Getting to know your appliance</b> .....	<b>8</b>		
Appliance .....	8		
Operating controls.....	8		
Fittings.....	9		
 <b>Operating the appliance</b> .....	<b>11</b>		
Switching the appliance on .....	11		
Switching off and disconnecting the appliance .....	11		
Setting the language .....	11		
Setting the temperature unit .....	11		
Setting the temperature.....	11		
Super freezing.....	11		
Automatic door opening .....	12		
Eco mode .....	12		
Switching ice cube production on and off.....	12		
Resetting water filter counter.....	12		
Theater mode .....	13		
Sabbath mode.....	13		

# Important safety instructions

READ INSTRUCTIONS - DO NOT DISCARD!

## Definitions

### **WARNING**

Non-observance of this warning could result in death or serious injuries.

### **CAUTION!**

Non-observance of this warning could result in slight or moderately serious injuries.

### **NOTICE:**

Non-observance of this information could damage the appliance.

**Note:** This indicates important information and/or tips.

## About these instructions

- Read and follow the operating and installation instructions. They contain important information on how to install, use and maintain the appliance.
- The manufacturer is not liable if you disregard the instructions and warnings in the operating and installation instructions.
- Retain all documents for subsequent use or for the next owner.

## Introduction

- This appliance complies with the relevant safety regulations for electrical appliances and is fitted with interference suppression.
- The refrigeration circuit has been checked for leaks.

## Explosion hazard

- Never use electric devices inside the appliance (e.g. heaters or electric ice makers).
- Do not store products which contain flammable propellants (e.g. spray cans) or explosive substances in the appliance.
- Store high-proof alcohol tightly closed and standing up.

## Risk of electric shock

Improper installations and repairs may put the user at considerable risk.

- Never cut through or remove the third (ground) conductor of the power cord.
- Never use adapters.
- Never defrost or clean the appliance with a steam cleaner. The steam can penetrate electrical parts and cause a short circuit.
- If the power cord is damaged: Immediately disconnect appliance from the power supply.
- Have the appliance, cable and accessories repaired or replaced only by the manufacturer, customer service or a similarly qualified person.
- Only use original parts supplied by the manufacturer. The manufacturer guarantees that these parts satisfy the safety requirements.
- A power cord extension may only be purchased from customer service.

## Risk of cold burns

- Never put frozen food straight from the freezer compartment into your mouth.
- Avoid prolonged contact of skin with frozen food, ice and the tubes in the freezer compartment.



## Intended use

READ INSTRUCTIONS - DO NOT DISCARD!

### Risk of injury

Containers which contain carbonated drinks may burst.

Do not store containers which contain carbonated drinks in the freezer compartment.

### Danger due to refrigerants

The tubes of the refrigeration circuit contain a small quantity of the environmentally friendly refrigerant R134a. It does not damage the ozone layer and does not increase the greenhouse effect. If refrigerant escapes, it may injure your eyes.

- Do not damage the tubes.

If the tubes are damaged:

- Ventilate the room.
- Switch off the appliance and pull out the mains plug.
- Call customer service.

### Avoiding risks for children:

- Never allow children to play with the appliance.
- Ensure that children have understood the hazards.
- A person responsible for safety must supervise or instruct children as soon as they are old enough to use the appliance.
- Supervise children while using the appliance, especially during cleaning and maintaining.

### Risk of suffocation

- If the appliance features a door lock: keep the key out of the reach of children.
- Keep children away from the packaging and its parts.

### Damage

To prevent damage:

- Do not stand or support yourself on the base, runners or doors.
- Keep plastic parts and door seals free of oil and grease.
- Pull the mains plug – not the power cord.

### Weight

The appliance is very heavy. The appliance should always be transported and set up by at least 2 persons.

→ "Installation and connection" on page 5

### State of California Proposition 65 Warnings

---

#### WARNING

This product contains chemicals known to the State of California to cause cancer, birth defects or other reproductive harm.

---

---

### Intended use

Use this appliance

- only for freezing food, making ice and dispensing drinking water.
- only in the home and in the home environment.
- only according to these operating instructions.

This appliance is intended for use at an elevation of no more than 2000 meters above sea level.

---

### Environmental protection

#### Packaging

All materials are environmentally safe and recyclable:

- Dispose of packaging in an environmentally friendly manner.
- Please ask your dealer or inquire at your local authority about current means of disposal.

## Old appliances

Valuable raw materials can be reclaimed by recycling old appliances.

### WARNING

CHILDREN MAY BECOME LOCKED IN THE APPLIANCE AND SUFFOCATE!

BEFORE DISPOSING OF YOUR OLD APPLIANCE:

- Remove the door.
- Leave shelves and containers in the appliance to prevent children from climbing in.
- Keep children away from the redundant appliance.

### CAUTION!

REFRIGERANT AND HARMFUL GASES MAY ESCAPE.

Do not damage the tubes of the refrigeration circuit and insulation.

1. Pull out the mains plug.
2. Cut through the power cord.
3. Have the appliance disposed of properly.

## Installation and connection

### Scope of supply

After unpacking all parts, check for any damage during transport.

If you have any complaints, please contact the dealer from whom you purchased the appliance or our customer service.

→ "Customer service" on page 17

The delivery consists of the following parts:

- Built-in appliance
- Fittings (depending on model)
- Installation material
- Instruction manual
- Installation instructions
- Customer service booklet
- Warranty enclosure
- Information on the energy consumption and noises

## Technical data

Refrigerant, cubic capacity and further technical specifications can be found on the rating plate.  
→ "Getting to know your appliance" on page 8

## Installing the appliance

### Installation location

The weight of the appliance may be up to 460 kg depending on the model. The base must be sufficiently stable and should not give. If necessary, reinforce the bottom.

### Built-in cut-out

The cut-out must fulfil these criteria:

- min. 24" (610mm) deep
- rectangular
- stable – the side panels and the top must be min. 5/8" (16mm) thick and securely attached to the bottom or wall
- shortened side panels must be min. 4" (100mm) deep

### Side-by-side installation

Side-by-side installation is only possible as follows:

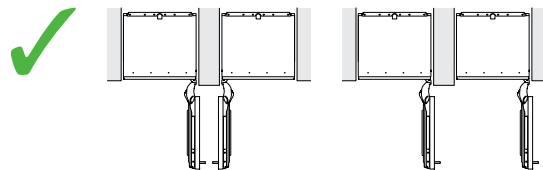
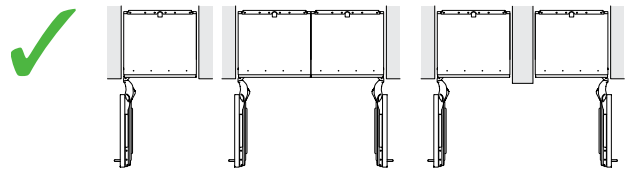
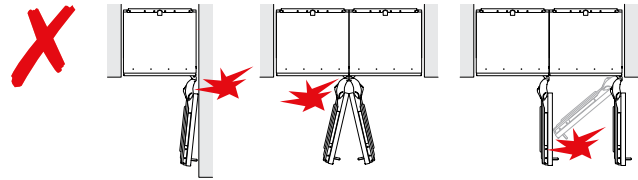

If you wish to install appliances in a different manner, there must be a partition wall between them. This partition wall must be min. 5/8" (16mm) in width.

## Saving energy

If you follow the instructions below, your appliance will use less power.

**Note:** The arrangement of the fittings does not affect the energy consumption of the appliance.

Installing the appliance	
Keep the appliance out of direct sunlight.	The appliance needs to cool less frequently at low ambient temperatures and therefore consumes less power.
Install the appliance as far away as possible from heating elements, cooker and other heat sources: 1 ¼" (3cm) to electric or gas cookers 1 1¼" (30cm) to oil or solid-fuel cookers <b>Note:</b> If this is not possible, attach an insulating plate between the appliance and heat source.	
Select an installation location at a room temperature of approx. 68 °F (20 °C).	
Use a niche depth of 24" (61cm).	The air on the back panel of the appliance does not warm up so intensely. The appliance consumes less power if the warm air can escape.
 <b>CAUTION!</b> <b>Risk of burns!</b> Individual parts on the back of the appliance become hot during operation. Touching these parts may result in burns.	
Do not cover or block the ventilation openings.	
Ventilate the room daily.	
Using the appliance	
Open the appliance door only briefly.	The air in the appliance does not warm up so intensely. The appliance needs to cool less frequently and therefore consumes less power.
Transport purchased food in a cool bag and place quickly in the appliance.	
Allow warm food and drinks to cool down before placing in the appliance.	
Defrost frozen food in the cooling compartment in order to utilize the low temperature of the frozen food.	
Always leave a space between the food and the back panel.	The air can circulate and the humidity will remain constant. The appliance needs to cool less frequently and therefore consumes less power.
Pack food airtight.	
Vacuum the back of the appliance once a year.	The air on the back panel of the appliance does not warm up so intensely. The appliance consumes less power if the warm air can escape.
Do not cover or block the ventilation openings.	

## Before using for the first time

1. Remove leaflets, adhesive tape and protective foil.
2. Clean the appliance.  
→ "Cleaning" on page 15

## Water connection

### CAUTION!

- Installation and connection of the appliance must be carried out by qualified technicians according to the installation instructions supplied.
- To avoid damage to the appliance and to ensure its proper functioning, it should only be connected to a drinking water system.
- To avoid water damage, a shut-off valve must be installed.

## Water pressure of drinking water system

### CAUTION!

To avoid damage to the appliance, a pressure relief valve must be installed between the drinking water connection and the tubing, should the water pressure exceed the maximum value.

**Note:** If the water pressure is too low, this will impair the relevant functions of the appliance.

- Min. 0.2 Mpa (2 bar)
- Max. 0.8 Mpa (8 bar)

## Electrical connection

### CAUTION!

Do not connect the appliance to electronic energy saver plugs.

**Note:** You can connect the appliance to mains-controlled and sine-controlled inverters.

Mains-controlled inverters are used for photovoltaic systems which are connected directly to the national grid. Sine-controlled inverters must be used for isolated applications. Isolated applications, e.g. on ships or in mountain lodges, are not directly connected to the national grid.

1. After installing the appliance, wait at least 1 hour before connecting it to prevent damaging the compressor.
2. Connect the appliance via a correctly installed outlet.

### WARNING

#### RISK OF ELECTRIC SHOCK!

The appliance must be properly grounded. Never cut through or remove the third (ground) conductor of the power cord. Never use adapters. Never use extension leads.

### Requirements for outlets

Outlet with	115 V
protective	60 Hz
conductor	
Fuse	10 A ... 16 A

### Maximum simultaneous load

Freezer 18"	3.5 A
Freezer 24"	4.0 A
Freezer 30"	4.5 A

3. Connect the appliance to a socket near the appliance.  
The socket must be freely accessible even after the appliance has been installed.

# Getting to know your appliance

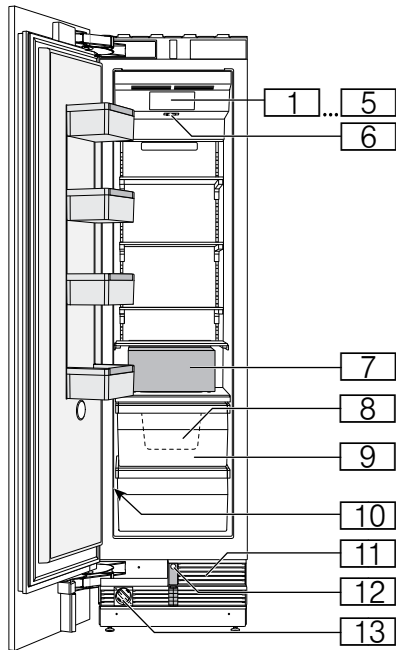

## Appliance

- 1 ... 5 Operating controls
- 6 Main On/Off switch
- 8 Ice maker
- 9 Ice cube container
- 9 Frozen food container
- 10 Rating plate
- 11 Ventilation opening
- 12 Automatic door opening
- 13 Water filter

## Operating controls

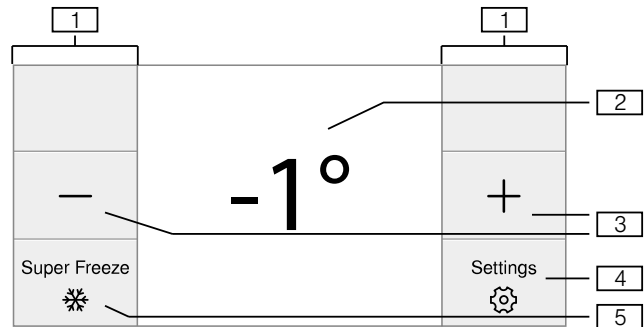

- 1 Touch fields  
There are sensors under the touch fields. Touching the symbol calls up the respective function.
- 2 Freezer compartment temperature display  
Indicates the set temperature in °C or °F.
- 3 +/- buttons  
Used to change the temperature.
- 4 ⚙ button  
Opens the **Settings** menu.
- 5 **Super Freeze** button  
Switches Super Freeze on or off.

## Menu settings

Press the ⚙ button to open the menu.

In the **Settings** menu, you will find:

- Appliance settings
- Cleaning mode
- Ice cube production
- Resetting water filter counter
- Eco mode
- Self-test
- Sabbath mode (if activated)

→ "Operating the appliance" on page 11

## Appliance settings menu

This is how to navigate to the **Appliance settings** menu:

1. Press the ⚙ button.
2. Scroll to the left to the **Appliance settings** menu.
3. Open the menu using the  button.

In the **Appliance settings** menu, you will find the following sub-menus and setting options:

- Brightness
- Key press sound
- Key volume
- Signal tone volume
- Automatic clean lock
- Automatic door opening
- Water filter counter
- Theater mode
- Temperature unit
- Language
- Factory settings
- Demo mode
- Sabbath mode

→ "Operating the appliance" on page 11



## Fittings

(not all models)

### Storage compartment

You can remove the storage compartment:

- Lift up storage compartment and remove.

### Shelf

You can vary the shelf:

1. Lift shelf and remove.
2. Insert hooks on back of shelf at same height to make it level.

**Note:** Insert shelf carefully to avoid scratches to appliance.

### Container

You can remove the container:

- Pull out the container.
- Lift the container at the rear and remove.

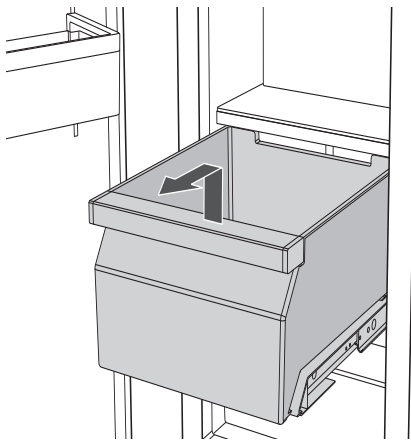

You can insert the container:

- Place the container onto the telescopic rails and push into the appliance.

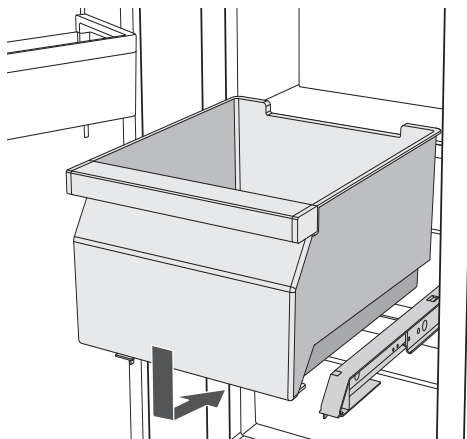

## Ice pack

In the event of a power failure or a fault:

- The ice pack delays the warming of the stored frozen food.

**Note:** The longest storage time is obtained by placing the ice pack on the food in the top compartment.

You can take out the ice pack to temporarily keep food cool, e.g. in a cool bag.

## Ice maker

### ⚠ CAUTION!

Damage to the appliance!

Never store bottles or food in the ice cube container, even for short periods. This can block and damage the ice maker.

Ice cube production starts as soon as the appliance has reached the set temperature.

**Note:** Ice cube production stops automatically when the ice cube container is full.

### Water filter

The water filter must be replaced after 6 months at the latest.

If the ice tastes stale, discard the rest of the ice cubes and the ones produced over the next 24 hours. If the ice still tastes stale, change the water filter.

A new water filter or a particle filter can be obtained from customer service or a specialist dealer.

**Note:** You can also use the appliance without a water filter. Replace the water filter with a particle filter and switch the water filter counter off. There is no need to change the particle filter.

### Replacing water filter

**Note:** After installing a new water filter, discard all ice cubes produced over the first 24 hours.

1. Turn the cap of the water filter counter-clockwise.
2. Take the water filter out.
3. Remove the protective cap of the new water filter.
4. Take off the cap of the old water filter and put it on the new water filter.
5. Slide the new water filter to the stop in the filter opening.

**Note:** The cap must be horizontal here.

6. Turn the water filter clockwise to the stop.
7. Discard the ice cubes produced over the first 24 hours.
8. Drain the water out of the old water filter.

**Note:** You can dispose of the old water filter with your household garbage.

**Specification and Performance Data Sheet**

Only for appliances with filter model: 9000 777 508

When using replacement cartridge: 9000 674 655

The concentration of the indicated substances dissolved in water entering the system was reduced to a concentration less than or equal to the permissible limit for water leaving the system as specified in ANSI/NSF Standard 42 and Standard 53.



System tested and certified by NSF International against ANSI/NSF Standard 53 and Standard 42 for the reduction of the claims specified on this Specification and Performance Data Sheet.

Capacity: 739.68 gallons/2,800 liters

Contaminant Reduction Determined by NSF testing.

Contaminant Reduction	Chlorine Taste and Odor	Nominal Particulate Class 1, $\geq 0.5$ to $<1.0 \mu\text{m}$	Cysts*	Turbidity
Average Influent	2.1 mg/L	9,100,000 pts/mL	170,000 cysts/L	11 NTU
NSF specified Challenge Concentration	2.0 mg/L +/- 10%	At least 10,000 particles/mL	Minimum 50,000 cysts/L	11 +/- 1 NTU
Avg. % Reduction	97.6%	98.8%	99.99%	98.1%
Average Product Water Concentration	0.05 mg/L	111,817 pts/mL	0.001 cyst/L	<1 NTU
Max. Permissible Product Water Concentration	N/A	N/A	N/A	0.5 NTU
NSF Reduction Requirements	$\geq 50\%$	$\geq 85\%$	$\geq 99.95\%$	95%
NSF Test Report	J-00121313	J-00099871	J-00109715	J-00099885

\* Based on the use of *Cryptosporidium parvum* oocysts.

Application Guidelines/Water Supply Parameters	
Service Flow	0.75 gpm (2.83 lpm)
Water Supply	Potable Water
Water Pressure	30 - 120 psi (207 - 827 kPa)
Water Temperature*	33 °F - 100 °F (0.6 °C - 38 °C)

It is essential that the manufacturer's recommended installation, maintenance and filter replacement requirements be carried out for the product to perform as advertised. See Installation Manual for Warranty information.

**Note:** While the testing was performed under standard laboratory conditions, actual performance may vary.

More detailed information on the prices of spare parts is available from your appliance dealer or parts vendor on site.

**WARNING**

**TO REDUCE THE RISK ASSOCIATED WITH INGESTION OF CONTAMINANTS:!**

Do not use with water that is microbiologically unsafe or of unknown quality without adequate disinfection before and after connection to the system. Systems certified for cyst reduction may be used on disinfected water that may contain filterable cysts.  
EPA Establishment Number 10350-MN-005

**CAUTION!**

To reduce the risks associated with property damage due to water leakage:

- Read and follow User Instructions before installation and use of this system.
- Installation and use must comply with all state and local plumbing codes.
- Do not install if water pressure exceeds 120 psi (827 kPa). If your water pressure exceeds 80 psi, you must install a pressure limiting valve.
- Contact a plumbing professional if you are uncertain how to check your water pressure.
- Do not install where water hammer conditions may occur. If water hammer conditions exist you must install a water hammer arrester. Contact a plumbing professional if you are uncertain how to check for this condition.
- Do not install on hot water supply lines. The maximum operating water temperature of this filter system is 100 °F (38 °C).
- Protect filter from freezing. Drain filter when temperatures drop below 33 °F (0.6 °C).
- The disposable filter cartridge must be replaced every 6 months, at the rated capacity or if a noticeable reduction in flow rate occurs.

Manufactured by:

- 3M Purification Inc.  
400 Research Parkway  
Meriden, Ct 06450  
Tel. (800) 222-7880  
Tel. (203) 237-5541

3M is a trademark of 3M Company used under license.

NSF is a trademark of NSF International.

© 2013 3M Company. All rights reserved.

## Operating the appliance

### Switching the appliance on

1. Press the **main On/Off switch**.  
The appliance starts cooling and the light is switched on when the door is open.
2. Set the required temperature.  
→ "Setting the temperature" on page 11

### Operating tips

- When the appliance has been switched on, it may take several hours until the set temperatures have been reached. Do not put in any food until the selected temperature has been reached.
- The fully automatic NoFrost system ensures that the freezer compartment remains free of ice. Defrosting is not required.
- The front sides of the housing are partly heated slightly. This prevents condensation in the area of the door seal.
- If the freezer compartment door cannot be immediately re-opened after it has been closed, wait until the resulting low pressure has equalized.

### Switching off and disconnecting the appliance

#### Switching off the appliance

- Press **main On/Off** switch.  
The appliance is no longer cooling.

#### Disconnecting the appliance

#### **CAUTION!**





Deterioration in water quality

The water supply must be turned off 3 hours before disconnecting. This prevents mold forming with any unused water.

If you do not use the appliance for a prolonged period:

1. Turn off the water supply to the appliance and wait 3 hours.
2. Remove groceries.
3. Press **main On/Off** switch.
4. Pull out mains plug or switch off fuse.  
The appliance is no longer cooling.
5. Empty the ice cube container and clean the appliance. → "Cleaning" on page 15
6. Leave appliance open.

### Setting the language





1. Press  button to open the **Settings** menu.
2. Use < button to move to the menu item **Appliance settings**.
3. Press the  button.
4. Use < button to move to the menu item **Language**.
5. Press the  button.
6. Use < > buttons to move to the required language.
7. Press the  button.  
The display restarts, and the start screen is displayed.

### Setting the temperature unit

You can choose between the unit °C and °F.

1° <=> 1 °F

1°C <=> 1 °C

1. Press  button to open the **Settings** menu.
2. Use < button to move to the menu item **Appliance settings**.
3. Press the  button.
4. Use < button to move to the menu item **Temperature unit**.
5. Press the  button.
6. Use < > buttons to move to the required unit.
7. Press the  button.  
The unit will be changed.
8. Press  button to exit the menu.

### Setting the temperature

#### Recommended temperature

Freezer compartment: 0 °F (-18 °C)

#### Freezer compartment

- Keep pressing the button +/- until the display indicates the required temperature.

### Super freezing

Super freezing cools the freezer compartment as cold as possible.

Switch on Super freezing, e.g.:

- to freeze food solid as quickly as possible
- 4 ... 6 hours before freezing food weighing 2 kg or more
- to use the max. freezing capacity

**Note:** When Super freezing is switched on, increased operating noises may occur.

After approx. 2 ½ days the appliance switches to normal operation.



#### Switching super freezing on or off

- Press the  button.

## Automatic door opening

The automatic door opening function supports you in opening the door. As soon as you activate this function, automatic door opening moves out and supports you in opening the door.

### Open menu item "Aut. door opening":

1. Press the  button.
2. Scroll to the left to the **Appliance settings** menu.
3. Press the  button.
4. Scroll to the right to the menu item **"Aut. door opening"**.
5. To change the setting, press the  button.

### Switching on Push-to-open system

In an installation situation without handles you can select the Push-to-open system. Your appliance will then open a crack if you press lightly on the door.

1. Open menu item **Aut. door opening**.
2. Select menu item **Push-to-open system**.
3. Press the  button.
4. Select menu item **Opening force**. Here you can select the level of force required to activate automatic door opening.
5. Select menu item **Opening duration**. Here you can select how long the door should remain open a crack before it closes again automatically.

---

#### CAUTION!

To prevent damaging the appliance, do not close the door while automatic door opening is still moved out. If you have however closed the door, leave it closed for 5 minutes. Automatic door opening will re-adjust itself. Repeatedly closing the door too early will cause automatic door opening to fail or wear out.

---

**Note:** If the door only remains open a crack, the appliance checks once a second whether the door is still ajar. After the selected opening time elapses, the appliance will close the door automatically.

### Switching on Pull-to-open system

In an installation situation with handles you can select the Pull-to-open system. Your appliance will support you in opening the door as soon as you pull on the handle.

1. Open menu item **Aut. door opening**.
2. Select menu item **Pull-to-open system**.
3. Press the  button.
4. Select menu item **Opening force**. Here you can select the level of force required to activate automatic door opening.

### Switching off automatic door opening

1. Open menu item **Aut. door opening**.
2. Select menu item **Off**.
3. Press the  button.

## Eco mode

Eco mode switches the appliance to energy-saving operation.

### The appliance automatically sets the following temperatures:

- Freezer compartment: +3 °F (-16 °C)

### Switching Eco mode on or off

1. Press  button to open the **Settings** menu.
2. Use **>** button to move to the menu item **Eco mode**.
3. Press the **▷/□** button.

The temperature is changed, and the display shows the new temperature.

**Note:** You can also switch Eco mode on or off by adjusting the temperature with the +/- buttons.

## Switching ice cube production on and off

---

#### CAUTION!

Damage to the appliance!

Never store bottles or food in the ice cube container, even for short periods. This can block and damage the ice maker.

---

Ice cube production starts as soon as the appliance has reached the set temperature.



**Note:** Ice cube production stops automatically when the ice cube container is full.

### Switching ice maker on or off

1. Press  button to open the **Settings** menu.
2. Use **>** button to move to the menu item **Ice cube production**.
3. Press the **▷/□** button.

## Resetting water filter counter

After replacing the water filter, you have to reset the water filter counter.





1. Press  button to open the **Settings** menu.
2. Use **>** button to move to the menu item **Water filter counter**.
3. Use the  button to confirm, and confirm the query again with the  button.

**Note:** The water filter counter will not be reset if you abort the query or take longer than 10 seconds to make an input.

## Theater mode

If Theater mode is switched on, the light will slowly become brighter when the appliance is opened, and then slowly darker when it is closed.

### Switching Theater mode on or off

1. Press  button to open the **Settings** menu.
2. Use < button to move to the menu item **Appliance settings**.
3. Press the  button.
4. Use > button to move to the menu item **Theater mode**.
5. Press the  button.
6. Use > button to move to the menu item **ON** or **OFF**. Confirm by pressing the  button.

## Sabbath mode





The appliance switches off the following:

- Ice maker
- Audible signals
- Interior light
- Messages on the control panel
- Background illumination of control panel is reduced

### Switching Sabbath mode on or off



#### Displaying Sabbath mode in the Settings menu

To use Sabbath mode, you first have to display the function in the **Settings** menu:

1. Press  button to open the **Settings** menu.
2. Use < button to move to the menu item **Appliance settings**.
3. Press the  button.
4. Use < button to move to the menu item **Sabbath mode**. Press the  button.
5. Use < button to move to the menu item **Available**. Confirm by pressing the  button.

The function is added to the **Settings** menu.

#### Switching on Sabbath mode

1. Press  button to open the **Settings** menu.
2. Press the  button to open the view **Duration Sabbath mode**.
3. Select one of the presets or change the duration with the +/- buttons.
4. Press the  button to start.  
The appliance switches all listed functions off.

#### Switching Sabbath mode off

- After the selected time elapses, the appliance switches over to normal operation.
- To end Sabbath mode before expiry of the selected time, press the  button.

## Alarm

### Door alarm

If the appliance door is open for a long time, the door alarm (continuous audible signal) switches on.

- Close door.  
The audible warning signal is switched off.

## Freezer compartment

The freezer compartment is suitable for:

- storing frozen food
- making ice cubes
- freezing food

The temperature can be set from -11 °F (-24 °C)... +7 °F (-14 °C).

The freezer compartment can be used to store perishable foods long-term almost without any noticeable reduction in quality as the low temperatures considerably slow down or stop deterioration. Appearance, flavor and all valuable ingredients are largely retained.

The time between putting fresh food in the freezer compartment and it freezing solid depends on the following factors:

- temperature set
- type of food
- amount of food in the freezer compartment
- quantity and type of storage

### Fully utilizing the freezer volume

To place the maximum quantity of frozen food in the freezer compartment:

- Remove all fittings.
- Store food directly on the shelves and on the floor of the freezer compartment.

### Purchasing frozen food

- Ensure the packaging is not damaged.
- Do not exceed the minimum sell-by date.
- Temperature in the supermarket freezer must be 0 °F (-18 °C) or lower.
- If possible, transport frozen food in a cool bag and place quickly in the freezer compartment.

## When loading products

- Freeze large quantities of food in the top compartment.  
This is where it will freeze especially quickly and gently.
- Distribute food in the compartments or frozen food containers.
- Do not bring food which is to be frozen into contact with frozen food.  
If required, restack frozen food in the frozen food containers.
- Important for unrestricted air circulation in the appliance:  
push in frozen food containers up to the limit stop.

## Freezing fresh food

Freeze only fresh and undamaged food.

Food which is boiled, fried or baked is more suitable for freezing than food which is raw.

Before freezing food, make preparations appropriate to the food in order to retain the best possible nutritional value, flavor and color:

- Vegetables: wash, chop, blanch.
- Fruit: wash, pit and perhaps peel, possibly add sugar or ascorbic acid solution.

Information on how to do this can be found in the relevant literature.

### Suitable for freezing

- Baked goods
- Fish and seafood
- Meat
- Poultry and game
- Vegetables, fruit and herbs
- Eggs without shells
- Dairy products, e.g. cheese, butter and quark
- Ready meals and leftovers, e.g. soups, stews, cooked meat and fish, potato dishes, soufflés and desserts

### Not suitable for freezing

- Types of vegetables which are usually eaten raw, e.g. lettuce or radishes
- Unpeeled or hard-boiled eggs
- Grapes
- Whole apples, pears and peaches
- Yoghurt, soured milk, sour cream, creme fraiche and mayonnaise

## Packing frozen food

The correct type of packaging and material selection are decisive factors in the retention of the product quality and prevent the development of freezer burn.

1. Place food in packaging.
2. Remove air.
3. Pack food airtight to prevent it from losing flavor and drying out.
4. Label packaging with contents and date of freezing.

Suitable packaging:

- Plastic foil
- Tubular foil made of polyethylene (PE)
- Aluminum foil
- Freezer containers

Suitable closures:

- Rubber bands
- Plastic clips
- Cold-resistant adhesive tape

Unsuitable packaging:

- Wrapping paper
- Greaseproof paper
- Cellophane
- Garbage bags and used grocery bags

### Shelf life of frozen food at 0 °F (-18 °C)

Fish, sausage, ready meals, cakes and pastries:	up to 6 months
---	----------------

Meat, poultry:	up to 8 months
----------------	----------------

Fruit, vegetables:	up to 12 months
--------------------	-----------------

## Thawing frozen food

The defrosting method must be adjusted to the food and application in order to retain the best possible product quality.

Defrosting methods:

- in the cooling compartment (especially suitable for animal-based foods such as fish, meat, cheese, quark)
- at room temperature (bread)
- in the microwave (food for immediate consumption or immediate preparation)
- in the oven/cooker (food for immediate consumption or immediate preparation)

---

### CAUTION!

Do not refreeze partly or completely thawed food. You can only refreeze the food when it has been used for a ready-to-eat meal (boiled or fried).

The frozen food can no longer be stored for the maximum duration.

---



## Defrosting

### Freezer compartment

The fully automatic NoFrost system ensures that the freezer compartment remains free of ice. Defrosting is no longer required.

## Cleaning

### CAUTION!

AVOID DAMAGING THE APPLIANCE AND THE FITTINGS.

- Do not use abrasive, chloride or acidic cleaning agents or solvents.
- Do not use scouring or abrasive sponges. The metallic surfaces may corrode.
- Never clean the shelves or containers in the dishwasher. The parts may become deformed.

Proceed as follows:

1. Press **main On/Off** switch.
2. Take out food and store in a cool location. Place ice pack (if available) on the food.
3. Clean the appliance with a soft cloth, lukewarm water and a little pH-neutral washing-up liquid.

### CAUTION!

The rinsing water must not run into the light or through the drainage hole into the evaporation area.

4. Wipe door seal with clear water and dry thoroughly with a cloth.
5. Switch appliance back on and put in food.

## Noises

### Normal noises

**Droning:** A motor is running, e.g. refrigerating unit, ventilator.

**Bubbling, buzzing or gurgling:** Refrigerant is flowing through the tubes.

**Clicking:** Motor, switches or solenoid valves are switching on and off.

**Cracking:** Automatic defrosting is running.

### Preventing noises

**Appliance is not level:** Align appliance using a water level. If required, place a little packing underneath.

**Containers, shelves or storage compartments wobble or stick:** Check the removable fittings and re-insert if required.

## Lighting

Your appliance features a maintenance-free LED light.

Only customer service or authorized technicians may repair the light.

## Faults – what to do?

Before you call customer service, use this table to check whether you can rectify the fault yourself.

### Appliance

<b>Temperature differs greatly from the set value.</b>	
	Switch off appliance for 5 minutes. → <i>"Switching off and disconnecting the appliance" on page 11</i> If the temperature is too warm, check temperature again after a couple of hours. If the temperature is too cold, check temperature again on the following day.
<b>Displays do not illuminate.</b>	
The mains plug has not been inserted properly.	Connect the mains plug.
The fuse has tripped.	Check the fuses.
The power has failed.	Check whether the power is on.
<b>The refrigeration unit is switching on more frequently and for longer.</b>	
The appliance was opened frequently.	Do not open the appliance unnecessarily.
The ventilation openings are covered up.	Remove obstacles.
Large quantities of fresh food have been put in.	Switch on Super Freeze in good time.
<b>Display indicates E...</b>	
Electronics have detected a fault.	Call customer service. → <i>"Customer service" on page 17</i>
<b>Appliance is not cooling, display and lighting are lit.</b>	
Showroom mode switched on.	Start the appliance self-test. → <i>"Appliance self-test" on page 17</i> When the program has ended, the appliance switches over to normal operation.

### Ice maker

<b>The ice maker is not functioning.</b>	
Ice cube production is switched off.	Switch on ice cube production.
Freezer compartment is too warm.	Set the temperature lower. → <i>"Operating the appliance" on page 11</i>
Ice cube container is not properly inserted.	Insert ice cube container fully.
Ice maker without power.	Call customer service. → <i>"Customer service" on page 17</i>
No water supply.	Check water connection and contact technician if necessary.
Low water pressure.	Only connect appliance to pipes with sufficient water pressure.
Kink in water hose.	Turn off water supply, straighten out kink. Replace water hose, if necessary.



**Too few or deformed ice cubes, water pressure lower than usual.**

After switching on or removing many ice cubes, there will be too few in the ice cube container. It takes around 24 hours for an empty ice cube container to fill up.

Low water pressure.

Only connect appliance to pipes with sufficient water pressure.

The water filter is blocked or needs to be replaced.

Replace water filter.

Freezer compartment is too warm.

Set the temperature lower.  
→ "Operating the appliance" on page 11

**Water is leaking out of the appliance.**

Water connection is not tight.

Have water hose replaced by manufacturer's original part.

**Customer service**

If you are unable to rectify the fault, please contact our customer service. We will always find an appropriate solution in order to avoid unnecessary visits by engineers.

The contact information for your nearest customer service can be found here or on the enclosed customer service list.



When calling, please state the product number (E-Nr.) and the production number (FD) which can be found on the rating plate.

→ "Getting to know your appliance" on page 8

**Trust the expertise of the manufacturer.** You can therefore be sure that the repair is carried out by trained service technicians who carry original spare parts for your home appliances.

**Appliance self-test**

Your appliance features a self-test program which displays the fault which your customer service can rectify.

1. Press  button to open the **Settings** menu.
2. Use **>** button to move to the menu item **Self-test**.
3. Use the  button to start the self-test.  
The self-test starts.
4. If faults are present, they will be displayed. In this case follow the instructions.
5. The appliance restarts.
6. The message that the self-test has finished is displayed for 10 seconds.

When the self-test has ended, the appliance switches over to normal operation.

**Repair order and advice on faults**

Contact information for all countries can be found on the enclosed customer service list.

USA	1-800-735-4328	Toll-free in the USA
CA	1-800-735-4328	

8001031712  
en-us (9604)



***Thermador***<sup>®</sup>

1901 Main Street, Suite 600, Irvine, CA 92614 • 1-800-735-4328  
www.thermador.com • © 2014 BSH Home Appliances Corporation