



Electric Warming Drawer

Safety Information 2

Warranty 4

Assistance / Accessories 6

Using The Warming Drawer
 Features 7
 Operating Tips 8

Care and Cleaning
 Cleaning The Warming Drawer 11

Installation Instructions 12

Troubleshooting Tips 20

Owner's Manual & Installation Instructions

CW9000
PJ7000
PW9000

Write the model and serial numbers here:

Model # _____

Serial # _____

You can find them on a label located on the backside of the lower drawer front.

In Canada, contact us at:
www.GEAppliances.ca

IMPORTANT SAFETY INFORMATION. READ ALL INSTRUCTIONS BEFORE USING.

⚠ WARNING

Read all safety instructions before using the product. Failure to follow these instructions may result in fire, electrical shock, serious injury or death.

⚠ WARNING IMPORTANT SAFETY NOTICE

All warming drawers can tip and injury could result if not properly installed.

To prevent accidental tipping of the warming drawer, attach it to the wall with an anti-tip brace as described in the Installation Instructions.

⚠ WARNING GENERAL SAFETY INSTRUCTIONS

- Use this appliance only for its intended purpose as described in this Owner's Manual.
- Be sure your appliance is properly installed and grounded by a qualified installer in accordance with the provided installation instructions.
- Do not attempt to repair, replace or clean any part of your warming drawer unless it is specifically recommended in this manual. All other servicing should be transferred to a qualified technician.
- Before performing any service, disconnect the power supply at the household distribution panel by removing the fuse or switching off the circuit breaker.
- Do not leave children alone—children should not be left alone or unattended in an area where an appliance is in use. They should never be allowed to climb, sit or stand on any part of the appliance.
- **⚠ CAUTION**: Do not store items of interest to children in cabinets above a warming drawer - children climbing on the warming drawer to reach items could be seriously injured.
- Use only dry pot holders—moist or damp pot holders on hot surfaces may result in burns from steam. Do not let pot holders touch hot heating elements. Do not use a towel or other bulky cloth in place of pot holders.
- Never use your appliance for warming or heating the room.
- Do not touch the heating elements or the interior surface of the warming drawer. These surfaces may be hot enough to burn even though they are dark in color. During and after use, do not touch, or let clothing or other flammable materials contact any interior area of the warming drawer; allow sufficient time for cooling first. Other surfaces of the appliance may become hot enough to cause burns. Potentially hot surfaces include the warming drawer vent opening, surfaces near the opening and crevices around the warming drawer door.
- Do not heat unopened food containers. Pressure could build up and the container could burst, causing an injury.
- Do not use aluminum foil to line the warming drawer bottom. Foil can trap heat or melt, resulting in damage to the product and a shock or fire hazard.
- Avoid scratching or impacting glass doors or control panels. Doing so may lead to glass breakage. Do not cook on a product with broken glass. Shock, fire or cuts may occur.
- The purpose of the warming drawer is to hold hot cooked foods at serving temperature (greater than 140°F). Bacteria will grow in food while it is below 140°F. Therefore, always start with hot food; cold food cannot be heated or cooked in the warming drawer.

SAVE THESE INSTRUCTIONS

⚠ WARNING**KEEP FLAMMABLE MATERIALS AWAY FROM THE WARMING DRAWER****Failure to do so may result in fire or personal injury.**

- Do not store or use flammable materials in or near a warming drawer, including paper, plastic, pot holders, linens, wall coverings, curtains, drapes and gasoline or other flammable vapors and liquids.
- Never wear loose-fitting or hanging garments while using the appliance. These garments may ignite if they contact hot surfaces, causing severe burns.
- Do not let cooking grease or other flammable materials accumulate in or near the warming drawer. Grease in the warming drawer or near the warming drawer may ignite.

⚠ WARNING**IN THE EVENT OF A FIRE, TAKE THE FOLLOWING STEPS TO PREVENT INJURY AND FIRE SPREADING**

- Do not use water on grease fires. Never pick up a flaming pan.
- If there is a fire in the warming drawer, smother the fire by closing the warming drawer door and turning the warming drawer off or by using a multi-purpose dry chemical or foam-type fire extinguisher.

⚠ WARNING**WARMING DRAWER SAFETY INSTRUCTIONS**

- Stand away from the warming drawer when opening the warming drawer door. Hot air or steam which escapes can cause burns to hands, face and/or eyes.
- Keep the warming drawer vent unobstructed.
- Keep the warming drawer free from grease buildup. Grease in the warming drawer may ignite
- Place warming drawer racks in desired location while warming drawer is cool. If rack must be moved while warming drawer is hot, do not let pot holder contact hot heating element in warming drawer.
- Do not leave items such as paper, cooking utensils or food in the warming drawer when not in use. Items stored in a warming drawer can ignite.

SAVE THESE INSTRUCTIONS

Thank You! ... for your purchase of a GE Brand appliance.

(For customers in the United States)

Register Your Appliance: Register your new appliance on-line at your convenience!

www.geappliances.com/service_and_support/register/

Timely product registration will allow for enhanced communication and prompt service under the terms of your warranty, should the need arise. You may also mail in the pre-printed registration card included in the packing material.

GE Electric Warming Drawer Warranty

GEAppliances.com

All warranty service is provided by our Factory Service Centers, or an authorized Customer Care® technician. To schedule service, on-line, visit us at www.geappliances.com/service_and_support/, or call 800.GE.CARES (800.432.2737). Please have serial number and model number available when calling for service.

Servicing your appliance may require the use of the onboard data port for diagnostics. This gives a GE factory service technician the ability to quickly diagnose any issues with your appliance and helps GE improve its products by providing GE with information on your appliance. If you do not want your appliance data to be sent to GE, please advise your technician not to submit the data to GE at the time of service.

For the period of one year from the date of the original purchase. GE will provide any part of the cooktop which fails due to a defect in materials or workmanship. During this limited one-year warranty, GE will also provide, free of charge, all labor and in-home service to replace the defective part.

What GE will not cover:

- Service trips to your home to teach you how to use the product.
- Improper installation, delivery or maintenance.
- Failure of the product if it is abused, misused, modified or used for other than the intended purpose or used commercially.
- Replacement of house fuses or resetting of circuit breakers.
- Damage to the product caused by accident, fire, floods or acts of God.
- Damage to finish, such as surface rust, tarnish, or small blemishes not reported within 48 hours of delivery.
- Incidental or consequential damage caused by possible defects with this appliance.
- Damage caused after delivery.
- Product not accessible to provide required service.
- Service to repair or replace light bulbs, except for LED lamps.

EXCLUSION OF IMPLIED WARRANTIES

Your sole and exclusive remedy is product repair as provided in this Limited Warranty. Any implied warranties, including the implied warranties of merchantability or fitness for a particular purpose, are limited to one year or the shortest period allowed by law.

This warranty is extended to the original purchaser and any succeeding owner for products purchased for home use within the USA. If the product is located in an area where service by a GE Authorized Servicer is not available, you may be responsible for a trip charge or you may be required to bring the product to an Authorized GE Service location for service. In Alaska, the warranty excludes the cost of shipping or service calls to your home.

Some states do not allow the exclusion or limitation of incidental or consequential damages. This warranty gives you specific legal rights, and you may also have other rights which vary from state to state. To know what your legal rights are, consult your local or state consumer affairs office or your state's Attorney General.

Warrantor: General Electric Company. Louisville, KY 40225

Staple your receipt here. Proof of the original purchase date is needed to obtain service under the warranty.

Thank You! ... for your purchase of a GE Brand appliance.

(For customers in Canada)

All warranty service provided by our Factory Service Centres or an authorized Customer Care® technician. For service, call 1.800.361.3400. Please have serial number and model number available when calling for service.

Mabe Electric Warming Drawer Warranty

For one year from the date of the original purchase.

Any part of the warming drawer which fails due to a defect in materials or workmanship. During this limited one-year warranty, Mabe will also provide, free of charge, all labor and in-home service to replace the defective part.

What GE will not cover:

- Service trips to your home to teach you how to use the product.
- Improper installation, delivery or maintenance.
- Failure of the product if it is abused, misused, modified or used for other than the intended purpose or used commercially.
- Replacement of house fuses or resetting of circuit breakers.
- Damage to the product caused by accident, fire, floods or acts of God.
- Damage to finish, such as surface rust, tarnish, or small blemishes not reported within 48 hours of delivery.
- Incidental or consequential damage caused by possible defects with this appliance.
- Damage caused after delivery.
- Product not accessible to provide required service.
- Service to repair or replace light bulbs, except for LED lamps.

EXCLUSION OF IMPLIED WARRANTIES

Your sole and exclusive remedy is product repair as provided in this Limited Warranty. Any implied warranties, including the implied warranties of merchantability or fitness for a particular purpose, are limited to one year or the shortest period allowed by law.

Warrantor Is Not Responsible For Consequential Damages.

Warrantor: Mabe Canada Inc.

Staple your receipt here. Proof of the original purchase date is needed to obtain service under the warranty.

Have a question or need assistance with your appliance?

Try the GE Appliances Website (www.geappliances.com/service_and_support/) 24 hours a day, any day of the year! For greater convenience and faster service, you can now download Owner's Manuals, order parts or even schedule service on-line.

Schedule Service: Expert GE repair service is only one step away from your door. Get on-line and schedule your service at www.geappliances.com/service_and_support/ Or call 800.GE.CARES (800.432.2737) during normal business hours.

Parts and Accessories: Individuals qualified to service their own appliances can have parts or accessories sent directly to their homes (VISA, MasterCard and Discover cards are accepted). Order on-line today, 24 hours every day or by phone at 800.626.2002 during normal business hours.

Instructions contained in this manual cover procedures to be performed by any user. Other servicing generally should be referred to qualified service personnel. Caution must be exercised, since improper servicing may cause unsafe operation.

Real Life Design Studio: GE supports the Universal Design concept of products, services and environments that can be used by people of all ages, sizes and capabilities. We recognize the need to design for a wide range of physical and mental abilities and impairments. For details of GE's Universal Design applications, including kitchen design ideas for people with disabilities, check out our Website today. For the hearing impaired, please call 800.TDD.GEAC (800.833.4322).

Contact Us: If you are not satisfied with the service you receive from GE, contact us on our Website with all the details including your phone number, or write to:
General Manager, Customer Relations
GE Appliances, Appliance Park Louisville, KY 40225

Accessories

Looking For Something More?

GE offers a variety of accessories to improve your cooking and maintenance experiences!

To place an order visit us online at:

www.GEApplianceParts.com (U.S.) or www.GEAppliances.ca (Canada)

or call **800.626.2002** (U.S.) **800.661.1616** (Canada)

The following products and more are available:

Accessories

27" Wide Custom Panel Kit	ZXD27B
30" Wide Custom Panel Kit	ZXD30B
30" Monogram Pro Panel Kit	ZXD9030P

Parts

Wire Rack	WB48X10045
-----------	------------

Cleaning Supplies

CitruShine Stainless Steel Wipes	WX10X10007
CERAMA BRYTE® Stainless Steel Appliance Cleaner	PM10X311

How to Remove Protective Shipping Film and Packaging Tape

Carefully grasp a corner of the protective shipping film with your fingers and slowly peel it from the appliance surface. Do not use any sharp items to remove the film. Remove all of the film before using the appliance for the first time.

To assure no damage is done to the finish of the product, the safest way to remove the adhesive from packaging tape on new appliances is an application of a household liquid dishwashing detergent. Apply with a soft cloth and allow to soak.

NOTE: The adhesive must be removed from all parts. It cannot be removed if it is baked on.

Features

Not all features are on all models. Appearance may vary.

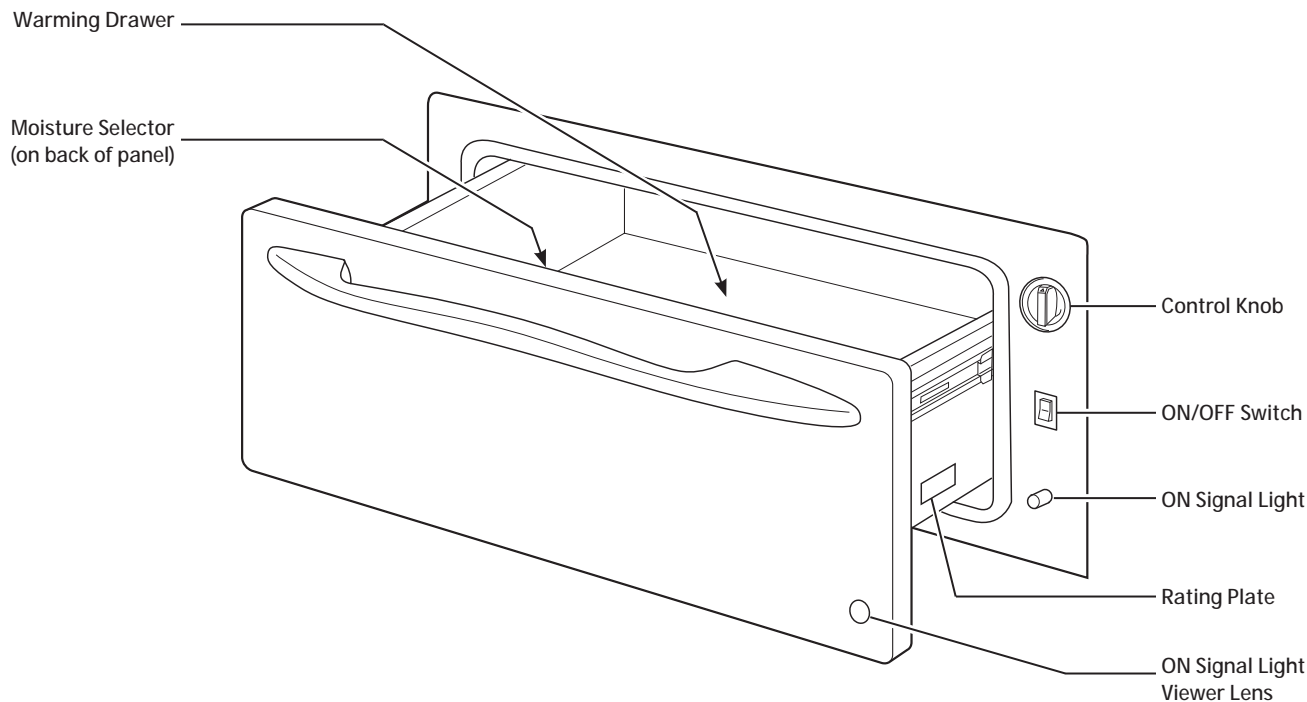

The warming drawer will keep hot, cooked foods at serving temperature. Always start with hot food. Do not use to heat cold food other than proofing yeast dough, crisping crackers, chips or dry cereal.

Control Knob

The warming drawer controls are hidden with the drawer shut. Open the drawer. The controls are on the right side of the front frame.

To use the warming drawer, press the **ON/OFF** switch to the ON position.

Slide the moisture selector control to the open or closed setting (See the Moisture Selector section).

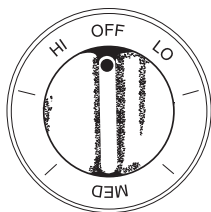

Turn the control knob to the desired setting.

PROOF	75–95°F
LOW	140–160°F
MED	160–195°F
HIGH	195–230°F

ON Signal Light

The ON signal light is located below the ON/OFF switch and glows when the ON/OFF switch is in the ON position. It stays on until the ON/OFF switch is moved to the OFF position.

The ON signal light is visible through the light viewer in the drawer front panel when the drawer is closed. This is a reminder that the heat is on.

Moisture Selector

The moisture selector is located on the inside front of the drawer.

To keep foods moist, slide the moisture selector control away from the control knob. This closes the vent and seals the moisture inside the drawer. With the vent closed hot foods stay moist and soft.

In this setting condensation may occur around the inside edge of the drawer.

To keep foods crisp, slide the moisture selector control to the right towards the control knob. This opens the vents and allows the moisture to escape.

With the vents open, it is normal for moisture to collect on surfaces above the warming drawer.

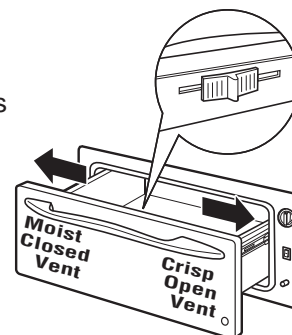

Operating Tips

Rack

- Rack will fit from front to back.
- Preheat with the rack in place.
- Using the rack allows for double stacking of items.

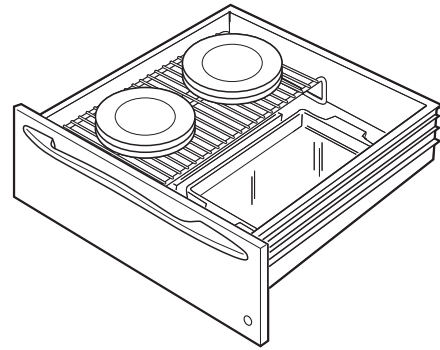
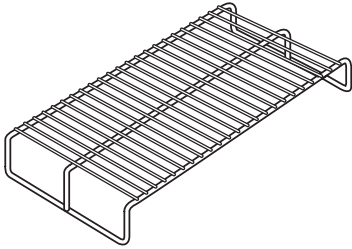

Double stacking items with the rack in position.

When Using The Warming Drawer

Do not line the warming drawer with aluminum foil.

- Allow time for the drawer to be preheated:
 - LOW** 8 minutes
 - MED** 15 minutes
 - HIGH** 20 minutes

NOTE: It is not necessary to preheat the drawer for proofing.

Food in heat-safe glass and glass ceramic pans may need higher thermostat setting as compared to food in metal pans.

- Repeated opening of the drawer allows the hot air to escape and the food to cool. Allow extra time for temperature inside the drawer to stabilize after adding items.

- With large loads it may be necessary to use a higher thermostat setting and cover some of the cooked food items.
- Food should be kept hot in its cooking container or transferred to a heat-safe serving dish.
- Aluminum foil may be used to cover food to prevent it from drying out.

⚠ CAUTION: Plastic containers or plastic wrap will melt if in direct contact with the drawer. Melted plastic may not be removable and is not covered under your warranty.

- Remove serving spoons, etc., before placing containers in warming drawer.

To Warm Serving Bowl And Plates

To warm serving bowls and plates set the control on LOW.

- Use only heat-safe dishes.
- Place the empty dishes on the rack to raise them off the bottom of the drawer. If you want hotter dishes or want to heat fine china, please check with the manufacturer of the dishes for their maximum heat tolerance.
- Preheat empty serving dish while preheating the drawer.

- When holding hot, cooked foods and warming empty serving dishes at the same time, place the serving dishes on the high rack position and the food on the bottom of the drawer.

⚠ CAUTION: Dishes may be hot. Use pot holders or mitts when removing hot dishes.

Operating Tips

To Proof Yeast Bread Dough

Yeast dough can be proofed in the warming drawer.

- Place your dish on the warming drawer bottom.
- You must always turn the control knob to **LOW** then immediately back to **PROOF**.
- Close the vent.
- Lightly oil the top of the dough in a bowl large enough to double the dough size. Cover with a cloth.
- Preheating not required for proofing.
- Check the dough height in 40 minutes. Add time as needed. The dough should remain in the drawer until it has doubled in size and a slight depression remains when the surface is touched gently with a finger.

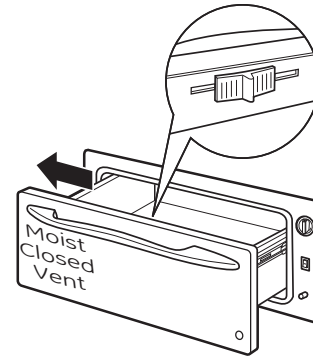

To Crisp Stale Items

- Place food in low sided dishes or pans.
- Preheat on LOW setting and open the vent.
- Check crispness after 45 minutes. Add time as needed.

Temperature Selection Chart for Crisp Foods

To keep several different foods hot, set the temperature to the food needing the highest setting. Place the items needing the highest setting on the bottom of the drawer and items needing less heat on the rack.

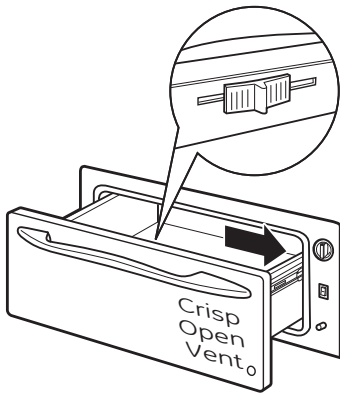

Food Type	Control Setting	Moisture Selector Setting
Bacon	HIGH	OPEN
Bread, hard rolls	MED	OPEN
Fried foods	HIGH	OPEN
Pies, two crusts	MED	OPEN
Pizza	HIGH	OPEN
Potatoes, baked	HIGH	OPEN
Tortilla Chips	LOW	OPEN

Tips:

- Leave food uncovered.
- Do not use plastic containers or plastic wrap.
- Preheat prior to use according to recommended times.

Operating Tips

Temperature Selection Chart for Moist Foods

To keep several different foods hot, set the temperature to the food needing the highest setting. Place the items needing the highest setting on the bottom of the drawer and items needing less heat on the rack.

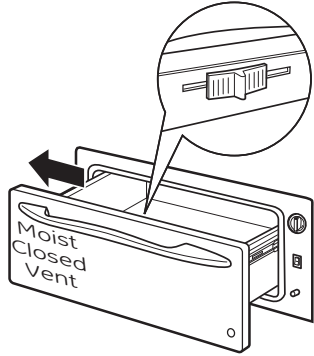

Food Type	Control Setting	Moisture Selector Setting
Beef, medium and well done*	MED	CLOSED
Bread, soft rolls	MED	CLOSED
Casseroles	MED	CLOSED
Cooked cereal	MED	CLOSED
Eggs	MED	CLOSED
Fish, seafood	MED	CLOSED
Fruit	MED	CLOSED
Gravy, cream sauces	MED	CLOSED
Ham	MED	CLOSED
Lamb	MED	CLOSED
Pancakes, waffles	HIGH	CLOSED
Pies, one crust	MED	CLOSED
Pork	MED	CLOSED
Potatoes, mashed	MED	CLOSED
Poultry	HIGH	CLOSED
Vegetables	MED	CLOSED

* USDA/FSIS recommends an internal temperature of 145°F. as the minimum doneness for beef. Use a portable meat thermometer to check internal temperatures.

Tips:

- Cover food with lid or aluminum foil.
- Do not put water in the warming drawer.
- Do not use plastic containers or plastic wrap.
- Preheat prior to use according to recommended times.

Cleaning The Warming Drawer

Be sure the controls are in the OFF position and all surfaces are cool before cleaning any part of the warming drawer.

Painted Or Enameled Surfaces

Use soap and warm water to thoroughly clean.

Rack

Clean the rack with detergent and water. After cleaning, rinse the rack with clean water and dry with a clean cloth.

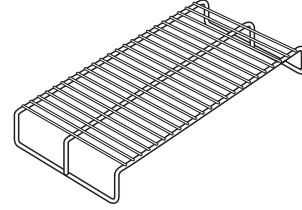

Stainless Steel

Do not use a steel wool pad; it will scratch the surface. To clean the stainless steel surface, use warm sudsy water or a stainless steel cleaner or polish. Always wipe the surface in the direction of the grain. Follow cleaner instructions for cleaning the stainless steel surface.

To inquire about purchasing cleaning products including stainless steel appliance cleaner or polish read the Assistance and Accessories sections at the beginning of this manual.

Control Knob

The control knob may be removed for easier cleaning. Make sure the knob is in the PROOF position and pull it straight off the stem for cleaning.

The knob can be cleaned in a dishwasher or it may also be washed with soap and water. Make sure the inside of the knob is dry before replacing. Replace the knob in the PROOF position to ensure proper placement.

Installation Instructions

Warming Drawer

PKD915, PTD915, CW9000, PJ7000 and PW9000

 "If you have questions, call 800.GE.CARES or visit our website at: GEAppliances.com"

BEFORE YOU BEGIN

Read these instructions completely and carefully.

- **IMPORTANT** – Save these instructions for local inspector's use.
- **IMPORTANT** – Observe all governing codes and ordinances.
- **Note to Installer** – Be sure to leave these instructions with the Consumer.
- **Note to Consumer** – Keep these instructions for future reference.
- Product failure due to improper installation is not covered under the Warranty.
- **⚠️ WARNING** – This appliance must be properly grounded.
- **⚠️ WARNING** – Insure that the power cord does not contact the hot surfaces on the bottom of ovens, cooktops, or any other appliance.
- **ATTENTION INSTALLER** – Proper installation is the responsibility of the installer and product failure due to improper installation is NOT covered under warranty.

MATERIALS YOU WILL NEED

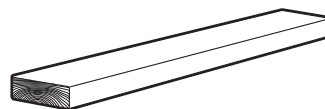

2 x 4 or 2 x 2 lumber for runners and brace

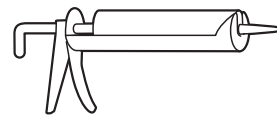

Wood screws and adhesive or other hardware for installing runners or shelf to support warmer drawer.

Runners must be level, rigidly mounted and capable of supporting 150 pounds.

TOOLS REQUIRED



Hand Saw



Safety Glasses

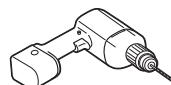

Drill and 1/16" Bit

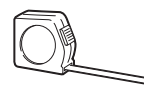

Measuring Tape



Phillips Screwdriver



Level



Cut Resistant Gloves

IMPORTANT SAFETY INSTRUCTIONS

GROUNDING THE APPLIANCE

IMPORTANT—(Please read carefully)

FOR PERSONAL SAFETY, THIS APPLIANCE MUST BE PROPERLY GROUNDED.

This warming drawer must be supplied with 120V, 60Hz, and connected to an individual, properly grounded branch circuit, and protected by a 15 or 20 amp circuit breaker or time delay fuse.

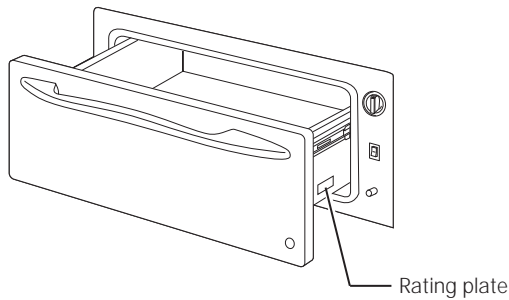

- A properly grounded 3-prong receptacle should be located within reach of the drawer's 56" long power cord.
- Locate the receptacle in an adjacent cabinet.
 - within 42" of the right side or,
 - within 16" of the left side or
 - A recessed receptacle may be located on the right side of the cutout, 7" maximum from the back of the cabinet. In this location, the excess power cord should be coiled and taped to the right side of the unit.

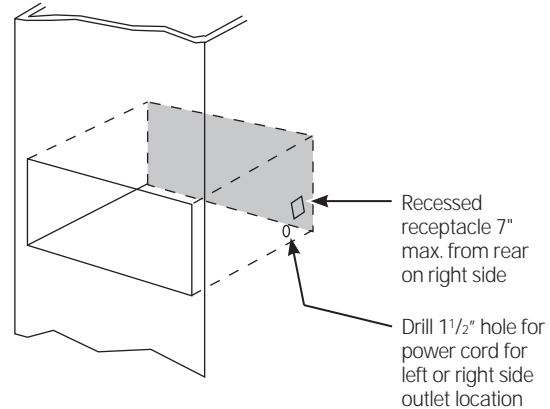

IMPORTANT—(Please read carefully)

The power cord of this appliance is equipped with a 3-prong (grounding) plug that mates with a standard 3-prong grounding wall receptacle to minimize the possibility of electric shock. The customer should have the wall receptacle and circuit checked by a qualified electrician to make sure the receptacle is properly grounded and has the correct polarity.

- Where a standard 2-prong wall receptacle is encountered, it is the personal responsibility and obligation of the customer to have it replaced with a properly grounded 3-prong wall receptacle.

Do not, under any circumstances, cut or remove the third (ground) prong from the power cord.

DO NOT USE AN EXTENSION CORD OR ADAPTER PLUG WITH THIS APPLIANCE. FOLLOW NATIONAL ELECTRICAL CODES AND ORDINANCES.

PRE-INSTALLATION CHECKLIST

- A** When preparing warming drawer cabinet, make sure the inside of the cabinet and the warming drawer do not interfere with each other. (see sections on preparing cabinet)
- B** REMOVE PACKAGING MATERIALS: Failure to remove packaging materials could result in damage to the appliance. Remove all packing parts from warming drawer including lifting up the warming drawer to confirm all packaging is removed.
- C** Remove Installation Instructions from literature pack and read them carefully before you begin. Be sure to place all literature, Owner's Manual, Installations, etc in a safe place for future reference.

Installation Instructions

PREPARING CABINET: BELOW A COUNTERTOP

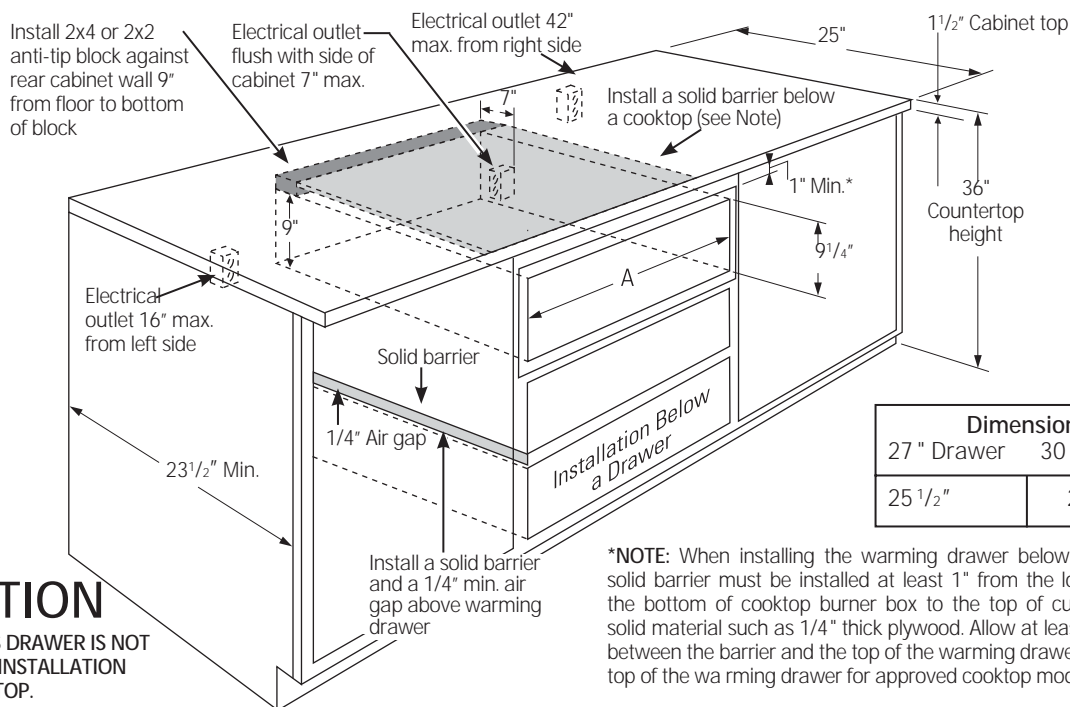

CAUTION

IN CANADA THIS DRAWER IS NOT APPROVED FOR INSTALLATION UNDER A COUNTERTOP.

- When installed, the front face of the warming drawer will be nearly flush with cabinetry doors or drawer fronts.
- Drawer overlaps will conceal cut edges on all sides of the opening.

The rough opening for the drawer must be:

- **Depth:** 23 1/2" minimum from inside back to front of cabinet frame.
- **Width:** 25 1/2" for 27" wide models
28 1/2" for 30" wide models.
- **Height:** 9 1/4"
- 5" minimum above floor or 1" above toekick.
23 1/4" from floor to bottom of cutout is recommended for under countertop installation.

Installation below a cabinet drawer:

The warming drawer may be installed beneath a cabinet drawer. In this installation, a solid barrier should be installed above the warming drawer to block access. Use any solid material such as 1/4" thick plywood. Allow at least 1/4" air gap between the barrier and the top of the warming drawer. Observe the 5" min. above the floor or 1" above the toekick min. installation height.

NOTE: If you are installing in frameless cabinets, it may be necessary to install 1/2" wide cleats to accept drawer mounting screws. See drawer to find exact locations of mounting screws.

When installed under a cooktop:

Warming drawers are suitable for installation below only certain specified cooktop models. See the label attached to the top of the warming drawer for suitable models. A solid barrier and air gap between cooktop and warming drawer is required. See Note above.

Installation Instructions

PREPARING CABINET: BELOW WALL OVENS

INSTALLATION BELOW A SINGLE OVEN

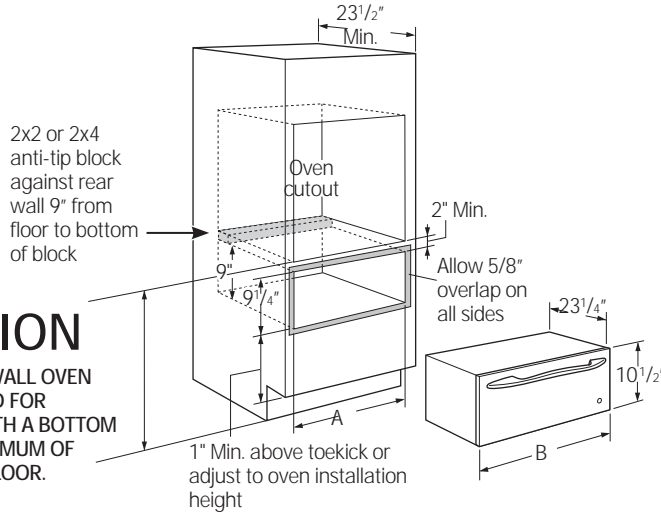

NOTE: Additional clearance between cutouts may be required. Check to be sure that oven supports above the warming drawer location do not obstruct the required interior 23 1/2" depth and 9 1/4" height.

CAUTION

IN CANADA, THE WALL OVEN IS ONLY APPROVED FOR INSTALLATION WITH A BOTTOM CUTOUT AT A MINIMUM OF 32.5" FROM THE FLOOR.

	Dimension A	Dimension B
27" Drawer	25 1/2"	26 3/4"
30" Drawer	28 1/2"	29 3/4"

INSTALLATION BELOW A DOUBLE OVEN

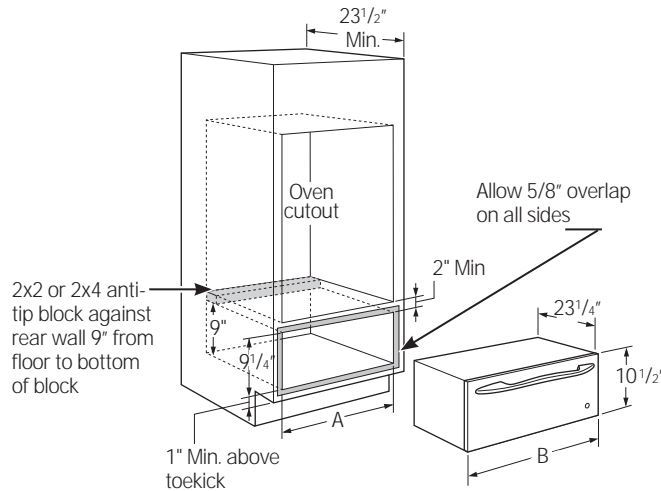

NOTE: Additional clearance between cutouts may be required. Check to be sure that oven supports above the warming drawer location do not obstruct the required interior 23 1/2" depth and 9 1/4" height.

CAUTION

IN CANADA, THIS DRAWER IS NOT APPROVED FOR INSTALLATION UNDER A DOUBLE OVEN.

- When installed, the front face of the warming drawer will be nearly flush with cabinetry doors or drawer fronts.
- Drawer overlaps will conceal cut edges on all sides of the opening.

The rough opening for the drawer must be:

- **Depth:** 23 1/2" minimum from inside back to front of cabinet frame.
- **Width:** 25 1/2" for 27" wide models
28 1/2" for 30" wide models.
- **Height:** 9 1/4"
- Allow 2" minimum between oven and drawer cutouts for clearance of overlaps

NOTE: If you are installing in frameless cabinets, it may be necessary to install 1/2" wide cleats to accept drawer mounting screws. See drawer to find exact locations of mounting screws.

When installed under a wall oven:

Warming drawers are suitable for installation below only certain specified wall oven models. See the label attached to the top of the warming drawer for suitable models.

NOTE: Electrical receptacle can be installed as shown for countertop installations. Do not install receptacle above the top of the warming drawer cutout.

Installation Instructions

INSTALLING CABINET SUPPORT

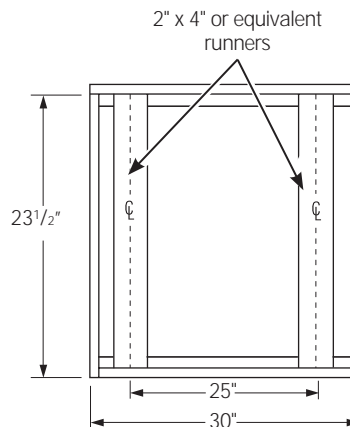
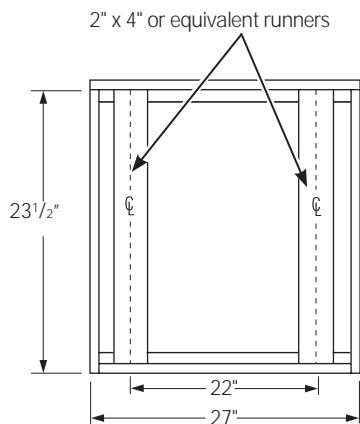

IMPORTANT: When installed below a single or double oven, check to be sure that any oven supports above the cutout do not obstruct the 23 1/2" required depth of the warming drawer cutout.

- A 2" minimum clearance between oven and warming drawer cutouts are required. Additional clearance may be required if 2 x 4 blocks are used to support runners or solid floor of the oven above.
- The warming drawer may be supported by either a solid bottom, 2 x 4 or 2 x 2 runners.

- The support must be level and rigidly mounted, flush with the bottom edge of the cutout.

There is no way to level the drawer once it has been installed. Be sure supports are level.

- The entire weight of the drawer is supported by the runners or solid floor and must be capable of supporting 150 lbs.

INSTALLING ANTI-TIP BRACE

• **⚠ WARNING: ANTI-TIP PRECAUTIONS:**

The anti-tip brace must be installed to prevent the drawer from tipping forward when opened and loaded.

Failure to do so could result in personal injury.

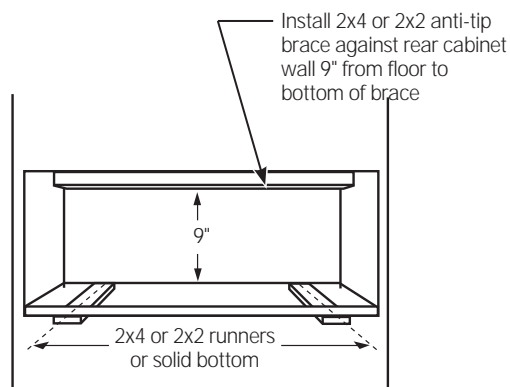

Installation Instructions

INSTALLING WARMING DRAWER

1. Slide the left corner into opening and push power cord into the hole leading to the outlet location. Thread the cord through as drawer is being pushed back into the opening.

If the outlet is installed inside the opening, plug the cord into the outlet. In this location, the excess power cord should be coiled and taped to the right side of the unit. Make sure the cord does not get trapped by the drawer.

NOTE: Insure that the power cord does not contact the hot surfaces on the bottom of ovens, cooktops, or any other appliance.

2. Push the drawer back until the front flange is flush to the cabinet front.
3. Open the drawer fully.

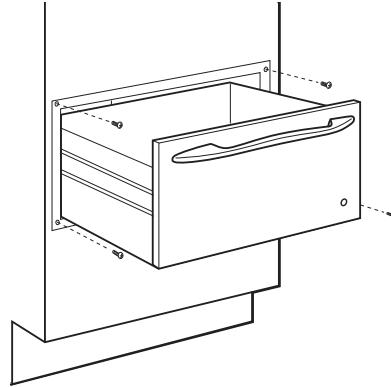

4. Drill pilot holes through the holes in the overlapping frame, one on each corner.
5. Drive wood screws provided into each corner.

Notes

Notes

Troubleshooting tips ... Before you call for service

Save time and money! Review the charts on the following pages first and you may not need to call for service.

Problem	Possible Cause	What To Do
Warming drawer will not work	A fuse in your home may be blown or the circuit breaker tripped.	Replace the fuse or reset the circuit breaker.
	Warming drawer not plugged in.	Plug in.
	Controls improperly set.	See the Using the warming drawer section.
Drawer does not slide smoothly or drags	Ball bearings out of alignment.	Fully extend the drawer and push it all the way in. See the Care and cleaning section.
	Drawer over-loaded or load unbalanced.	Reduce weight to less than 50 pounds. Redistribute drawer contents.
Excessive condensation	Liquid in warming drawer.	Remove liquid.
	Uncovered foods.	Cover food with lid or aluminum foil.
	Temperature setting too high.	Reduce temperature setting.
	Incorrect Moisture Selector setting.	Set the Moisture Selector to the open vent setting to allow venting.
No heat in the PROOF setting	Room temperature may prevent the thermostat from tripping on.	Turn the knob to LOW then back to PROOF.
Food dries out	Moisture escaping.	Cover food with lid or aluminum foil.