

— Installation assistance available at: —
RFTECH
— www.rockfordfosgate.com/rftech —

**POLARIS® RANGER®
PMX DASH KIT**

RFRNGR-PMXDK



600 South Rockford Drive • Tempe, Arizona 85281, United States
Direct: (480) 967-3565 • Toll Free: (800) 669-9899
ROCKFORDFOSGATE.COM

Installation & Operation

Introduction

Dear Customer,

Congratulations on your purchase of the world's finest brand of audio products. At Rockford Fosgate we are fanatics about musical reproduction at its best, and we are pleased you chose our product. Through years of engineering expertise, hand craftsmanship and critical testing procedures, we have created a wide range of products that reproduce music with all the clarity and richness you deserve.

For maximum performance we recommend you have your new Rockford Fosgate product installed by an Authorized Rockford Fosgate Dealer, as we provide specialized training through Rockford Technical Training Institute (RTTI). Please read your warranty and retain your receipt and original carton for possible future use.

Great product and competent installations are only a piece of the puzzle when it comes to your system. Make sure that your installer is using 100% authentic installation accessories from Rockford Fosgate in your installation. Rockford Fosgate has everything from RCA cables and speaker wire to power wire and battery connectors. Insist on it! After all, your new system deserves nothing but the best.

To add the finishing touch to your new Rockford Fosgate image order your Rockford accessories, which include everything from T-shirts to hats.

Visit our web site for the latest information on all Rockford products;

www.rockfordfosgate.com

or, in the U.S. call 1-800-669-9899 or FAX 1-800-398-3985. For all other countries, call +001-480-967-3565 or FAX +001-480-966-3983.

Table of Contents

| | |
|---|--------------|
| 2 | Introduction |
| 3 | Installation |
| 4 | Warranty |

If, after reading your manual, you still have questions regarding this product, we recommend that you see your Rockford Fosgate dealer. If you need further assistance, you can call us direct at **1-800-669-9899**. Be sure to have your serial number, model number and date of purchase available when you call.

PRACTICE SAFE SOUND

Continuous exposure to sound pressure levels over 100dB may cause permanent hearing loss. High powered auto sound systems may produce sound pressure levels well over 130dB. Use common sense and practice safe sound.

Safety

This symbol with "WARNING" is intended to alert the user to the presence of important instructions. Failure to heed the instructions will result in severe injury or death.



This symbol with "CAUTION" is intended to alert the user to the presence of important instructions. Failure to heed the instructions can result in injury or unit damage.



- To prevent injury and damage to the unit, please read and follow the instructions in this manual. We want you to enjoy this system, not get a headache.
- If you feel unsure about installing this system yourself, have it installed by a qualified Rockford Fosgate technician.
- Before installation, disconnect the battery negative (-) terminal to prevent damage to the unit, fire and/or possible injury.

Contents

- | | |
|-------------------------|-------------------------------|
| • (1) Main Dash Bezel | • PMX-0 Power Harness |
| • (1) PMX-2 Carrier | • (4) Butt Connectors |
| • (1) PMX-0 Carrier | • (8) Carrier Mounting Screws |
| • PMX-2 Vehicle Harness | • Plastic Wire Tie Wraps |
| • PMX-0 Vehicle Harness | • Grommet |

Installation Tools

The following is a list of suggested tools needed for installation:

- | | |
|-------------------------|----------------|
| • T-20 Torx Driver | • Wire Cutters |
| • 3 mm Allen Driver | • Panel Tool |
| • 10 mm Socket / Wrench | • Jigsaw |
| • 1.75" Hole Saw | • Masking Tape |
| • Drill | • File |
| • Drill Bit | |

Installation Considerations

This section focuses on some considerations for installing your Polaris RANGER dash kit. This dash kit is designed to work in conjunction with Rockford's other RANGER specific audio kits and parts.

If you feel unsure about installing this system yourself, have it installed by a qualified technician.

When drilling holes, make sure what is on the other side. Be sure that any electrical, fuel lines or any other important components are free and clear from the area.

⚠ WARNING

Before installation, disconnect the battery negative (-) terminal to prevent damage to the unit, fire and/or possible injury.

⚠ CAUTION

Before beginning any installation, follow these simple rules:

⚠ CAUTION

Be sure to carefully read and understand the instructions before attempting to install this wiring kit.

- Consult your UTV's service manual for model specific information. Models may differ from year to year depending on factory options and aftermarket accessories added.
- This dash kit is specifically designed to work with Rockford Fosgate's compact source units.
- With the addition of an amplifier or source unit, be sure that your current charging system is in proper working order.
- Visit rockfordfosgate.com for more comprehensive product information.
- Visit our **YouTube** channel for comprehensive installation videos demonstrating complete installation guides and install tips.

NEED HELP WITH YOUR INSTALLATION?



YOUTUBE VISIT OUR CHANNEL FOR A COMPLETE INSTALLATION VIDEO AND OTHER TIPS
WWW.YOUTUBE.COM/USER/ROCKFORDFOSGATE

Applicable Models:

Full Size Polaris RANGER 900/1000/ 900 Crew/1000 Crew

This dash kit enclosure is designed to work with Rockford Fosgate's RFRNGR-K8 amplifier kit and compact source units. The enclosure can be installed in both Crew and non-crew models on the passenger side of the vehicle.

- Step 1. Remove the top of the dash. This will give you access for installing the dash kit and wires.
- Step 2. Remove the existing factory dash bezel with your Torx driver.
- Step 3. Disconnect any existing switches or hardware on the original bezel.

Step 4. Mount the source unit to the new dash bezel.

NOTE: If you have heater controls, vents or additional switches, use the guides on the back of the bezel as a guide to cut out holes. Be sure to cut your holes prior to mounting any source unit.

Dash Kit with PMX-2/PMX-3 Option

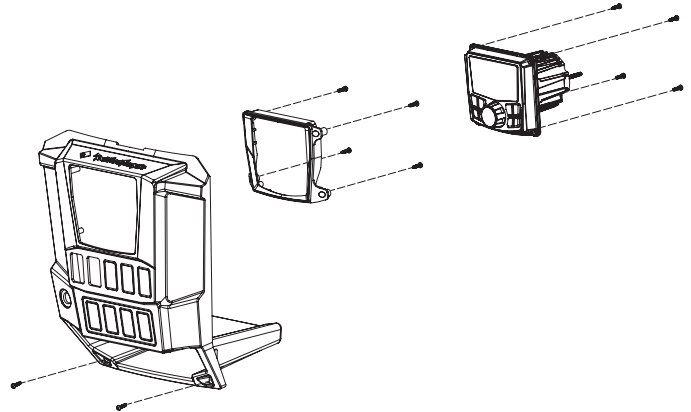

Dash Kit Assembly with PMX-0 Option

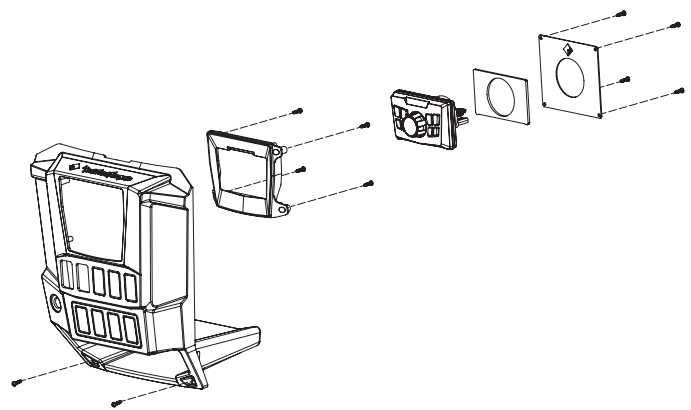

Step 5. Drill an access hole behind where the source will go in the firewall using a 1.75" hole saw.

Step 6. Install the supplied grommet into the access hole.

Step 7. Run the source unit harness through hole in firewall toward inside of the vehicle.

Step 8. Connect the RED and BLACK wires on the harness to the factory terminal block.

NOTE: When using the PMX-0 you will need to connect the YELLOW wire to the cigarette lighter.

Step 9. Plug the harness into the back of the source unit.

Step 10. Secure the dash using the (2) factory screws.

Step 11. Reinstall the dash top.

Warranty

Rockford Corporation offers a limited warranty on Rockford Fosgate products on the following terms:

Length of Warranty

POWER Amplifiers – 2 Years

BMW® Direct Fit Speakers – 2 Years

PUNCH® & PRIME® Amplifiers – 1 Year

Speakers, Signal Processors, Accessories and Capacitors – 1 Year

All marine, motorcycle, motorsport products - 2 Years

Any Factory Refurbished Product – 90 Days (receipt required)

What is Covered

This warranty applies only to Rockford Fosgate products sold to consumers by authorized Rockford Fosgate dealers in the United States of America. Products purchased by consumers from an Authorized Rockford Fosgate Dealer in another country are covered only by that country's Distributor and not by Rockford Corporation.

Who is Covered

This warranty covers only the original purchaser of Rockford product purchased from an authorized Rockford Fosgate dealer in the United States. In order to receive service, the purchaser must provide Rockford with a copy of the receipt stating the customer name, dealer name, product purchased and date of purchase.

Products found to be defective during the warranty period will be repaired or replaced (with a product deemed to be equivalent) at Rockford's discretion.

What is Not Covered

1. Damage caused by accident, abuse, improper installation, operations, theft, water (on non-Element Ready products).
2. Any cost or expense related to the removal or reinstallation of product.
3. Service performed by anyone other than Rockford or an authorized Rockford Fosgate service center.
4. Any product which has had the serial number defaced, altered, or removed.
5. Subsequent damage to other components.
6. Any product purchased outside the U.S.
7. Any product not purchased from an authorized Rockford Fosgate dealer. Refer to rockfordfosgate.com dealer locator for more detail.

Limit on Implied Warranties

Any implied warranties including warranties of fitness for use and merchantability are limited in duration to the period of the express warranty set forth above. Some states do not allow limitations on the length of an implied warranty, so this limitation may not apply. No person is authorized to assume for Rockford Fosgate any other liability in connection with the sale of the product.

How to Obtain Service

Please call 1-800-669-9899 for Rockford Customer Service. You must obtain an RA# (Return Authorization number) to return any product to Rockford Fosgate. You are responsible for shipment of product to Rockford.

EU Warranty

This product meets the current EU warranty requirements, see your Authorized dealer for details.