

MONOLITH

Design Guide

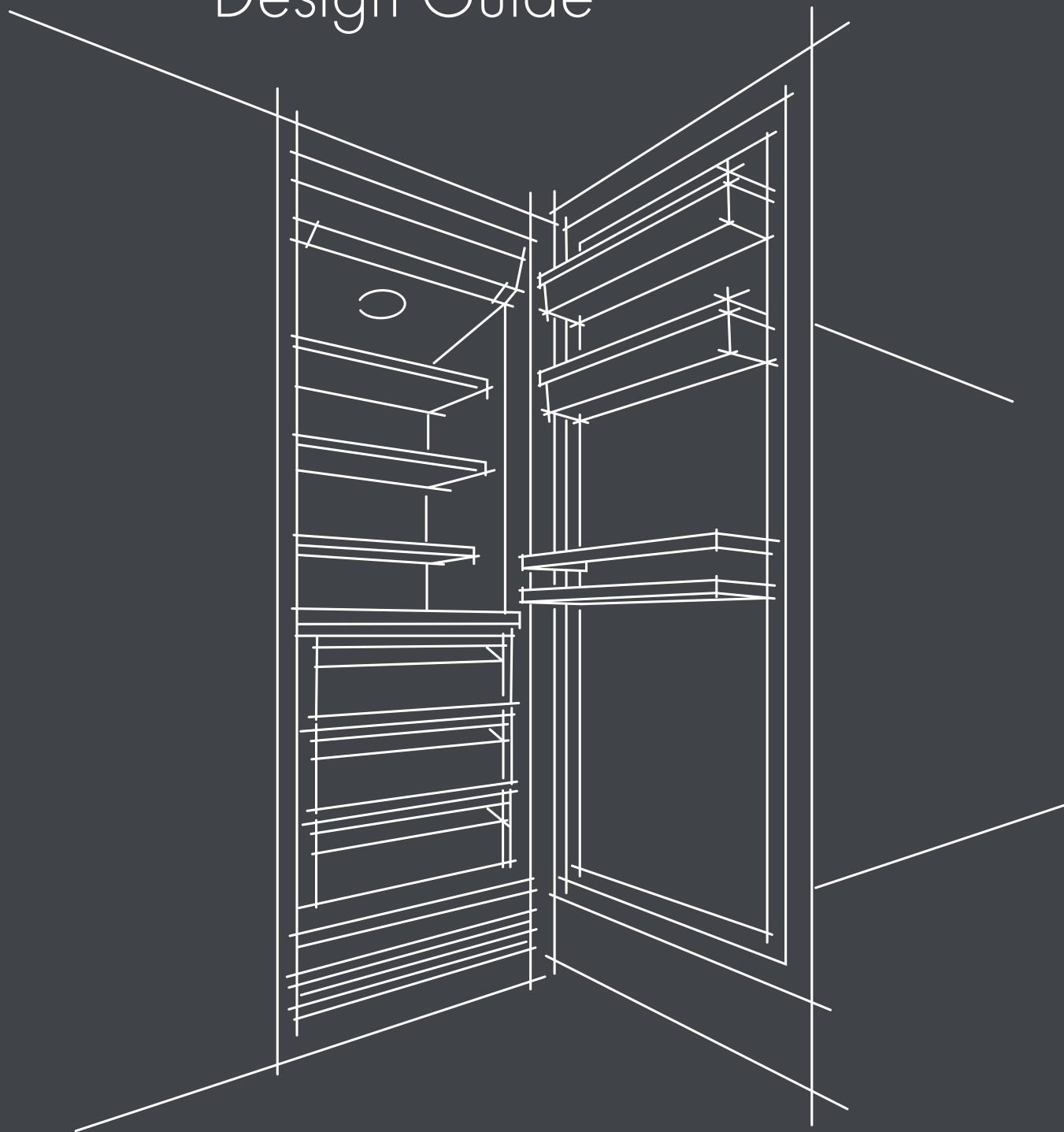

LIEBHERR







MONOLITH

Cooling Redefined

The next generation of home refrigeration is here. Introducing Monolith, a towering achievement in cooling technology from Liebherr. Monolith is the culmination of Liebherr's 60 years of refrigeration innovation and expertise. An impressive 84" from top to bottom, this monumental wonder of German engineering takes food preservation to a new level. With superior energy efficiency and food-saving advancements such as BioFresh-Plus, PowerCooling and our SmartDeviceBox, Monolith is a fusion of technical genius and practical ingenuity. Add Liebherr's exclusive InfinitySwipe electronic touch-control panel and smartphone app, whisper-quiet operation and infinite finishes and size configurations to match your décor, and you can see why Monolith isn't just state-of-the-art. It's the new definition of cool.

Columns Overview

Model	Door Hinge	Panel	Features
Refrigerator			
 MRB 2400 24"	Right, reversible	Stainless steel panel Custom panel	ENERGY STAR Bio Fresh Plus Infinity Light Soft System Soft Telescopic Smart Device Super Cool Power Cooling Super Quiet K
 MRB 3000 30"	Right, reversible	Stainless steel panel Custom panel	ENERGY STAR Bio Fresh Plus Infinity Light Soft System Soft Telescopic Smart Device Super Cool Infinity Spring Super Quiet K
 MRB 3600 36"	Right, reversible	Stainless steel panel Custom panel	ENERGY STAR Bio Fresh Plus Infinity Light Soft System Soft Telescopic Smart Device Super Cool Infinity Spring Super Quiet K
Freezer			
 MF 1851 18"	Left, reversible	Stainless steel panel Custom panel	ENERGY STAR Infinity Light Ice Maker Soft System Soft Telescopic Smart Device Super Frost Frost Safe System Super Quiet K
 MF 2451 24"	Left, reversible	Stainless steel panel Custom panel	ENERGY STAR Infinity Light Ice Maker Soft System Soft Telescopic Smart Device Super Frost Frost Safe System Super Quiet K
 MF 3051 30"	Left, reversible	Stainless steel panel Custom panel	ENERGY STAR Infinity Light Ice Maker Soft System Soft Telescopic Smart Device Super Frost Frost Safe System Super Quiet K
 MF 3651 36"	Left, reversible	Stainless steel panel Custom panel	ENERGY STAR Infinity Light Ice Maker Soft System Soft Telescopic Smart Device Super Frost Frost Safe System Super Quiet K

Side-by-Side Combinations

Monolith columns offer limitless combinations for your dream kitchen. These appliances can be installed as single columns, or in combinations of two and three appliances to maximize your storage options. See popular combinations listed below.

42-Inch

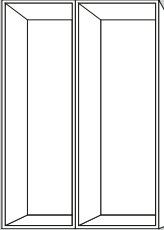

MF 1851
Freezer

MRB 2400
Refrigerator

18" | 24"

48-Inch

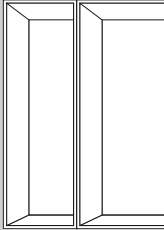

MF 1851
Freezer

MRB 3000
Refrigerator

18" | 30"

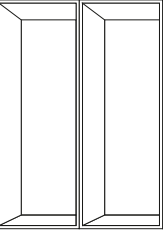

MF 2451
Freezer

MRB 2400
Refrigerator

24" | 24"

54-Inch



MF 2451
Freezer

MRB 3000
Refrigerator

24" | 30"

60-Inch

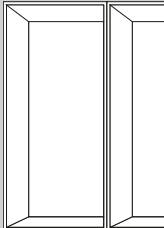

MF 3051
Freezer

MRB 3000
Refrigerator

30" | 30"



MF 2451
Freezer

MRB 3600
Refrigerator

24" | 36"

72-Inch

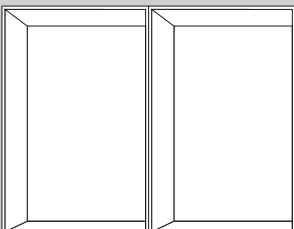

MF 3651
Freezer

MRB 3600
Refrigerator

36" | 36"

COOLING



Key Features



Infinity Swipe

InfinitySwipe: Monolith's intuitive electronic touch-control panel features a full-color 3.5-inch touch & swipe screen that's bright, clean, and wonderfully user-friendly. You'll barely have to lift a finger to control every function.



Smart Device

SmartDevice: Monolith comes with a SmartDeviceBox which can be controlled via a smartphone or tablet, activating settings and features while on the go. In the future SmartDevice can also help you become a better chef by using internal cameras to tell you what items you'll need for a recipe, and voice recognition to order what you're missing.



Bio Fresh

BioFresh: BioFresh is an advanced food preservation system featuring independent climate controls, where you can create a high-humidity environment for fruits and veggies in one drawer, and a low-humidity environment for meats and cheeses in another. **FlexSystem:** This simple-to-use organization system helps sort and separate foods stored in your favorite BioFresh drawer.



Bio Fresh Plus

BioFresh-Plus: Liebherr's BioFresh technology guarantees the perfect climate for superior, long-lasting food freshness. In addition to two BioFresh drawers, the third Monolith refrigerator drawer can be set as BioFresh-Plus, lowering temperatures down to 28 °F, ideal for storing fresh fish and seafood.



Infinity Spring

InfinitySpring: The seamlessly integrated, flush-mounted InfinitySpring internal water dispenser is there when you need it, and virtually invisible when you don't, and can accommodate pitchers of any size. Liebherr's filtration system eliminates harmful contaminants, resulting in crisp, clear, fresh tasting water.



Power Cooling

PowerCooling: Liebherr's high-performance PowerCooling system ensures that newly stored foods are quickly cooled, while maintaining an even temperature throughout the interior. Taking this system one step further, Monolith circulates cold air behind the door, meaning that items stored in the door stay just as cold as everything else inside.



Infinity Light

InfinityLight: Monolith's seamlessly integrated LED side-wall lighting casts a beautiful and even glow that can be adjusted according to taste, including a soft brightening effect upon opening the doors. InfinityLight doesn't just add drama and flair, it also emits less heat, preserving food quality.



Gallon Storage: Monolith's durable and elegant door shelves provide more cubic feet and convenience. Store gallon jugs of tea, juice and milk on the door, freeing up the refrigerator's interior shelves for everything from party platters to fresh salad bowls.

24" Monolith Refrigerator



MRB 2400	
Energy consumption (kWh/y)	230
Estimated Yearly Energy Cost in US \$	28*
Sound rating dB(A)	39**
Refrigerator capacity cu.ft. (l)	11.5 (325)
BioFresh/BioFresh-Plus comp. cu.ft. (l)	5.0 (142)
Number of shelves	4
Number of door racks	3
Number of BioFresh drawers/BioFresh-Plus drawers	2/1 with LED lighting
Electronic control	InfinitySwipe
Refrigerator temperature range °F (°C)	+36 °F to +45 °F (+2 °C to +7 °C)
Defrost type	automatic
Interior light	InfinityLight
Internal Water Dispenser	no
Water filter	no
Door hinges	right, reversible***
Product dimensions	
in inch H/W/D	83 3/4"/23 3/4"/24"
in cm H/W/D	212.6/60.2/61
Cut out dimensions	
in inch H/W/D	84"/24"/25"
in cm H/W/D	213.4/61/63.5
Net weight lbs. (kg)	335.1 (152.0)
Voltage V/Hz	115/60

* Estimated energy cost will depend on utility rates and use. Estimated energy cost based on a national average electricity cost of 12 cents per kWh.

** Noise output – according to EN 60704-3.

*** Please contact your Liebherr Authorized Dealer for door reversal.

Available Accessories

- Stainless steel door panel
- Monolith brushed aluminum square handle
- Monolith stainless steel round handle
- Monolith brushed aluminum soft-edge handle
- Stainless steel Toe Kick
- Reverse door kit

See pages 34–35 for available accessories.

Product Dimensions

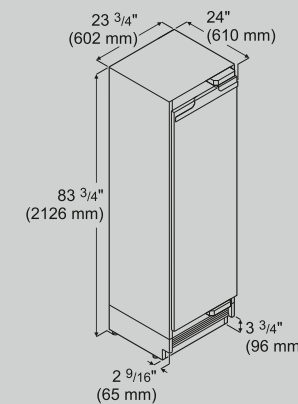

IMPORTANT!
Stated minimum height dimensions include when the leveled feet are fully inserted.

Height can be increased by a maximum of 1" (26 mm) by turning the adjustable feet. When the appliance is fitted in the recess, the appliance must be raised by turning the adjustable feet so that the appliance top has contact with the anti-tipping bracket. This results in a 4" (102 mm) Toe Kick height.

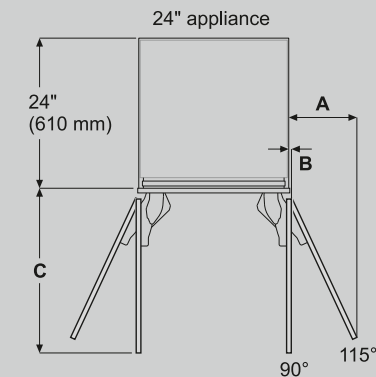

Inset
A = 10 3/4" (273 mm)
B = 1/2" (12.5 mm)
C = 25 7/8" (658 mm)

Frameless
A = 11" (279 mm)
B = 1/2" (12.5 mm)
C = 26 3/8" (670 mm)

Dimension A = without mounted door handle

Cut out Dimensions

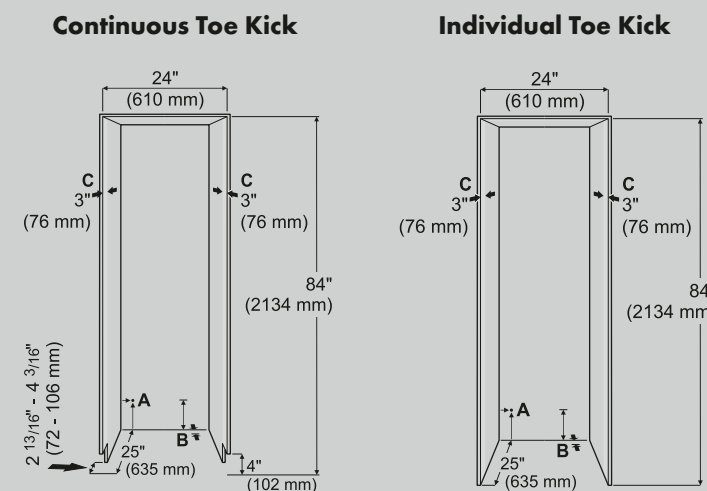

A
At this point the power cord exits from the appliance rear. 3/4" (19 mm) from the left and 5" (127 mm) from the floor. Free length of the power cord is 98" (2.5 m).

B
The appliance has a recess in this area for cable and waterline laying. 1" (25 mm) in depth and 5 1/2" (140 mm) in height over the whole width of the appliance.

C
This surface is visible when the appliance door is open. Designed finish is required.

Door Panel Dimensions

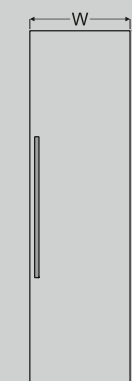

24" recess

Inset installation style

H = 79 7/8" (2029 mm)
W = 23 3/4" (603 mm)

Frameless installation style

H = 80" (2032 mm) Add overlapping dimension to the panel on the top.
W = 24" (610 mm) Add overlapping dimension to the panel on both sides.

Maximum panel weight = 52 lbs. (24 kg)

30" Monolith Refrigerator



◀30"▶

MRB 3000	
Energy consumption (kWh/y)	245
Estimated Yearly Energy Cost in US \$	30*
Sound rating dB(A)	39**
Refrigerator capacity cu.ft. (l)	15.0 (425)
BioFresh/BioFresh-Plus comp. cu.ft. (l)	6.5 (185)
Number of shelves	4
Number of door racks	3
Number of BioFresh drawers/BioFresh-Plus drawers	2/1 with LED lighting
Electronic control	InfinitySwipe
Refrigerator temperature range °F (°C)	+36 °F to +45 °F (+2 °C to +7 °C)
Defrost type	automatic
Interior light	InfinityLight
Internal Water Dispenser	InfinitySpring
Water filter	yes
Door hinges	right, reversible***
Product dimensions	
in inch H/W/D	83 3/4"/29 11/16"/24"
in cm H/W/D	212.6/75.4/61
Cut out dimensions	
in inch H/W/D	84"/30"/25"
in cm H/W/D	213.4/76.2/63.5
Net weight lbs. (kg)	394.6 (179.0)
Voltage V/Hz	115/60

* Estimated energy cost will depend on utility rates and use. Estimated energy cost based on a national average electricity cost of 12 cents per kWh.

** Noise output – according to EN 60704-3.

*** Please contact your Liebherr Authorized Dealer for door reversal.

Available Accessories

- Stainless steel door panel
- Monolith brushed aluminum square handle
- Monolith stainless steel round handle
- Monolith brushed aluminum soft-edge handle
- Stainless steel Toe Kick
- Reverse door kit

See pages 34–35 for available accessories.

Product Dimensions

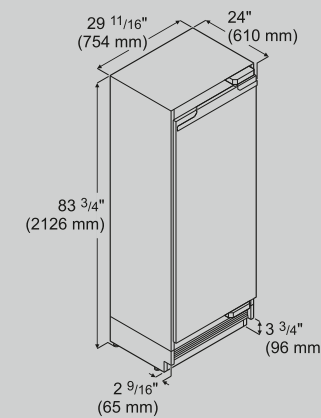

IMPORTANT!
Stated minimum height dimensions include when the leveled feet are fully inserted.

Height can be increased by a maximum of 1" (26 mm) by turning the adjustable feet. When the appliance is fitted in the recess, the appliance must be raised by turning the adjustable feet so that the appliance top has contact with the anti-tipping bracket. This results in a 4" (102 mm) Toe Kick height.

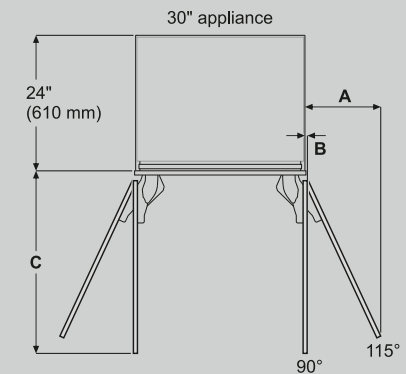

Inset
A = 13 1/4" (337 mm)
B = 1/2" (12.5 mm)
C = 31 7/8" (810 mm)

Frameless
A = 13 1/2" (343 mm)
B = 1/2" (12.5 mm)
C = 32 3/8" (822 mm)

Dimension A = without mounted door handle

Cut out Dimensions

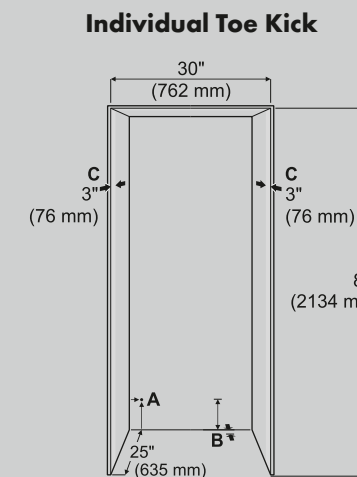
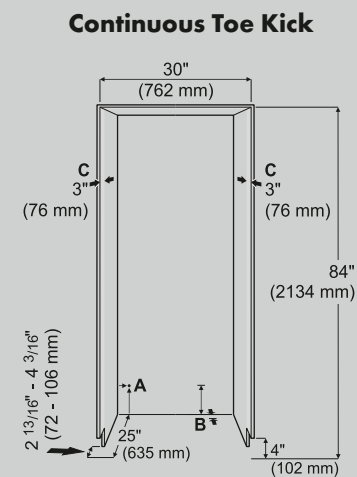

A
At this point the power cord exits from the appliance rear. 3/4" (19 mm) from the left and 5" (127 mm) from the floor. Free length of the power cord is 98" (2.5 m).

B
The appliance has a recess in this area for cable and waterline laying. 1" (25 mm) in depth and 5 1/2" (140 mm) in height over the whole width of the appliance.

C
This surface is visible when the appliance door is open. Designed finish is required.

Door Panel Dimensions

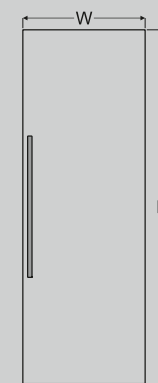

30" recess

Inset installation style

H = 79 7/8" (2029 mm)
W = 29 3/4" (756 mm)

Frameless installation style

H = 80" (2032 mm) Add overlapping dimension to the panel on the top.
W = 30" (762 mm) Add overlapping dimension to the panel on both sides.

Maximum panel weight = 66 lbs. (30 kg)

36" Monolith Refrigerator



◀36"▶

MRB 3600	
Energy consumption (kWh/y)	325
Estimated Yearly Energy Cost in US \$	39*
Sound rating dB(A)	39**
Refrigerator capacity cu.ft. (l)	18.9 (535)
BioFresh/BioFresh-Plus comp. cu.ft. (l)	8.3 (236)
Number of shelves	4
Number of door racks	3
Number of BioFresh drawers/BioFresh-Plus drawers	2/1 with LED lighting
Electronic control	InfinitySwipe
Refrigerator temperature range °F (°C)	+36 °F to +45 °F (+2 °C to +7 °C)
Defrost type	automatic
Interior light	InfinityLight
Internal Water Dispenser	InfinitySpring
Water filter	yes
Door hinges	right, reversible***
Product dimensions	
in inch H/W/D	83 3/4"/35 13/16"/24"
in cm H/W/D	212.6/90.9/61
Cut out dimensions	
in inch H/W/D	84"/36"/25"
in cm H/W/D	213.4/91/63.5
Net weight lbs. (kg)	385.8 (175.0)
Voltage V/Hz	115/60

* Estimated energy cost will depend on utility rates and use. Estimated energy cost based on a national average electricity cost of 12 cents per kWh.

** Noise output – according to EN 60704-3.

*** Please contact your Liebherr Authorized Dealer for door reversal.

Available Accessories

- Stainless steel door panel
- Monolith brushed aluminum square handle
- Monolith stainless steel round handle
- Monolith brushed aluminum soft-edge handle
- Stainless steel Toe Kick
- Reverse door kit

See pages 34–35 for available accessories.

Product Dimensions

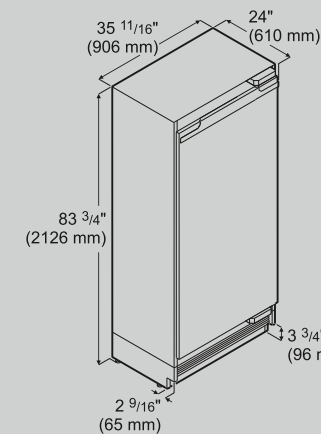

IMPORTANT!
Stated minimum height dimensions include when the leveled feet are fully inserted.

Height can be increased by a maximum of 1" (26 mm) by turning the adjustable feet. When the appliance is fitted in the recess, the appliance must be raised by turning the adjustable feet so that the appliance top has contact with the anti-tipping bracket. This results in a 4" (102 mm) Toe Kick height.

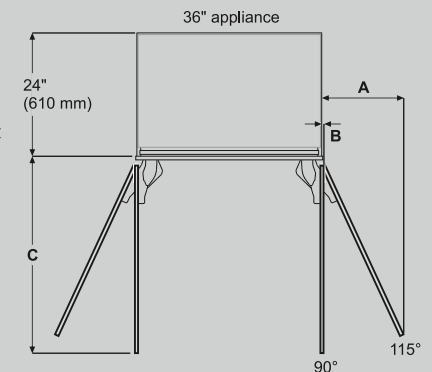

Inset
A = 15 3/4" (400 mm)
B = 1/2" (12.5 mm)
C = 37 7/8" (962 mm)

Frameless
A = 16" (416 mm)
B = 1/2" (12.5 mm)
C = 38 3/8" (975 mm)

Dimension A = without mounted door handle

Cut out Dimensions

Continuous Toe Kick

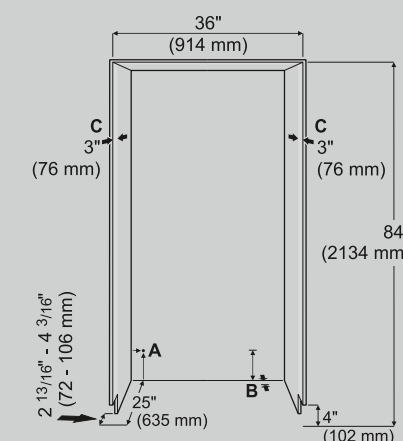

Individual Toe Kick

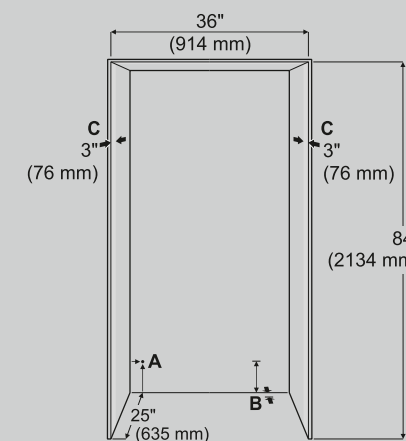

A
At this point the power cord exits from the appliance rear. 3/4" (19 mm) from the left and 5" (127 mm) from the floor. Free length of the power cord is 98" (2.5 m).

B
The appliance has a recess in this area for cable and waterline laying. 1" (25 mm) in depth and 5 1/2" (140 mm) in height over the whole width of the appliance.

C
This surface is visible when the appliance door is open. Designed finish is required.

Door Panel Dimensions

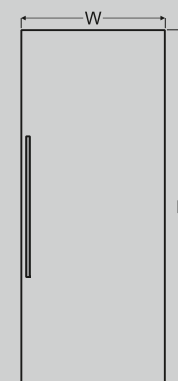

36" recess

Inset installation style

H = 79 7/8" (2029 mm)
W = 35 3/4" (908 mm)

Frameless installation style

H = 80" (2032 mm) Add overlapping dimension to the panel on the top.
W = 36" (914 mm) Add overlapping dimension to the panel on both sides.

Maximum panel weight = 88 lbs. (40 kg)

FREEZING



Key Features



Soft System

SoftSystem: Doors close automatically and gently thanks to our SoftSystem technology, which eliminates slamming even when shelves are fully loaded. Depending on which size Monolith you choose, the door hinges are rated for up to 88 pounds.



Ice Maker

IceMaker: Monolith's automatic IceMaker produces 3.5 pounds of filtered ice in 24 hours. Activate the SuperFrost function for an even greater production capability. With a 4-pound storage capacity, you'll never be without.



Freezer Door Bins: With their unique design, Monolith's durable freezer door bins allows cold air to flow freely, keeping temperature constant while optimizing food preservation. The see-through door bins are also fully adjustable, easily accommodating small to medium-sized items so that inner freezer shelves are free to accommodate bulkier foods.



Infinity Light

InfinityLight: Monolith's seamlessly integrated LED side-wall lighting casts a beautiful and even glow that can be adjusted according to taste, including a soft brightening effect upon opening the doors. InfinityLight doesn't just add drama and flair, it also emits less heat, preserving food quality.



Frost Safe System

FrostSafe Drawers: Monolith's FrostSafe sealed removable freezer drawers protect frozen food from unwanted air exchange and chilled air loss, even when the door is opened. FrostSafe drawers are also generously deep and transparent, providing an optimum view of what's stored within.



Super Frost

SuperFrost: Simply quick freeze just-bought groceries to preserve optimum food freshness, while sealing in flavors and maintaining essential vitamins and minerals.

18" Monolith Freezer



18"

MF 1851	
Energy consumption (kWh/y)	412
Estimated Yearly Energy Cost in US \$	50*
Sound rating dB(A)	39**
Freezer capacity cu.ft. (l)	7.8 (222)
Number of shelves	4
Number of door racks	3
Number of FrostSafe drawers	3
Electronic control	InfinitySwipe
Freezer temperature range °F (°C)	+7 °F to -17 °F (-14 °C to -27 °C)
Defrost type	automatic
Interior light	InfinityLight
Water filter	yes
IceMaker	fixed water connection
Ice cube output lbs. (kg) / 24h	3.5 (1.6)
Ice cube stock lbs. (kg)	4.0 (1.8)
Door hinges	left, reversible***
Product dimensions	
in inch H/W/D	83 3/4" / 17 3/4" / 24"
in cm H/W/D	212.6 / 45 / 61
Cut out dimensions	
in inch H/W/D	84" / 18" / 25"
in cm H/W/D	213.4 / 45.7 / 63.5
Net weight lbs. (kg)	302.0 (137.0)
Voltage V/Hz	115/60

* Estimated energy cost will depend on utility rates and use. Estimated energy cost based on a national average electricity cost of 12 cents per kWh.

** Noise output – according to EN 60704-3.

*** Please contact your Liebherr Authorized Dealer for door reversal.

Available Accessories

- Stainless steel door panel
- Monolith brushed aluminum square handle
- Monolith stainless steel round handle
- Monolith brushed aluminum soft-edge handle
- Stainless steel Toe Kick
- Reverse door kit

See pages 34–35 for available accessories.

Product Dimensions

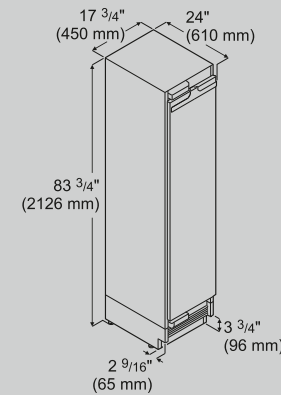

IMPORTANT!

Stated minimum height dimensions include when the leveled feet are fully inserted.

Height can be increased by a maximum of 1" (26 mm) by turning the adjustable feet. When the appliance is fitted in the recess, the appliance must be raised by turning the adjustable feet so that the appliance top has contact with the anti-tipping bracket. This results in a 4" (102 mm) Toe Kick height.

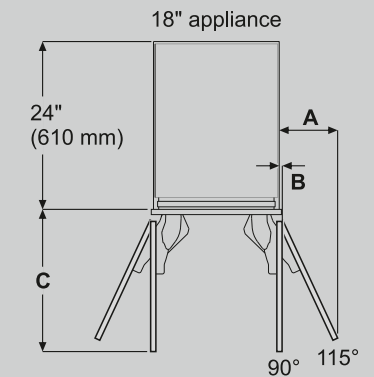

Inset

A = 8 1/4" (210 mm)
B = 1/2" (12.5 mm)
C = 19 7/8" (505 mm)

Frameless

A = 8 1/2" (216 mm)
B = 1/2" (12.5 mm)
C = 20 3/8" (517 mm)

Dimension A = without mounted door handle

Cut out Dimensions

Continuous Toe Kick

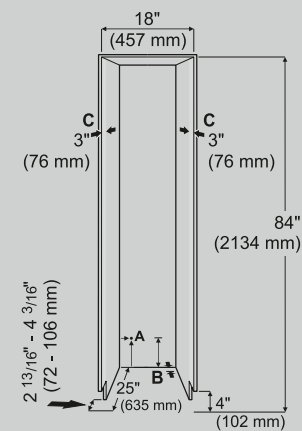

Individual Toe Kick

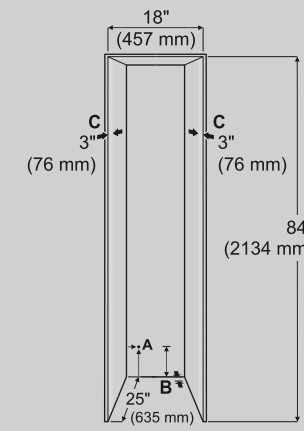

A

At this point the power cord exits from the appliance rear. 3/4" (19 mm) from the left and 5" (127 mm) from the floor. Free length of the power cord is 98" (2.5 m).

B

The appliance has a recess in this area for cable and waterline laying. 1" (25 mm) in depth and 5 1/2" (140 mm) in height over the whole width of the appliance.

C

This surface is visible when the appliance door is open. Designed finish is required.

Door Panel Dimensions

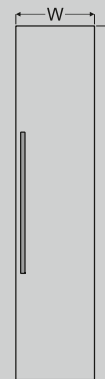

18" recess

Inset installation style

H = 79 7/8" (2029 mm)
W = 17 3/4" (451 mm)

Frameless installation style

H = 80" (2032 mm) Add overlapping dimension to the panel on the top.
W = 18" (457 mm) Add overlapping dimension to the panel on both sides.

Maximum panel weight = 40 lbs. (18 kg)

24" Monolith Freezer



◀24"▶

MF 2451	
Energy consumption (kWh/y)	438
Estimated Yearly Energy Cost in US \$	53*
Sound rating dB(A)	39**
Freezer capacity cu.ft. (l)	11.5 (325)
Number of shelves	4
Number of door racks	3
Number of FrostSafe drawers	3
Electronic control	InfinitySwipe
Freezer temperature range °F (°C)	+7 °F to -17 °F (-14 °C to -27 °C)
Defrost type	automatic
Interior light	InfinityLight
Water filter	yes
IceMaker	fixed water connection
Ice cube output lbs. (kg) / 24h	3.5 (1.6)
Ice cube stock lbs. (kg)	4.0 (1.8)
Door hinges	left, reversible***
Product dimensions	
in inch H/W/D	83 3/4" / 23 3/4" / 24"
in cm H/W/D	212.6 / 60.2 / 61
Cut out dimensions	
in inch H/W/D	84" / 24" / 25"
in cm H/W/D	213.4 / 61 / 63.5
Net weight lbs. (kg)	346.1 (157.0)
Voltage V/Hz	115/60

* Estimated energy cost will depend on utility rates and use. Estimated energy cost based on a national average electricity cost of 12 cents per kWh.

** Noise output – according to EN 60704-3.

*** Please contact your Liebherr Authorized Dealer for door reversal.

Available Accessories

- Stainless steel door panel
- Monolith brushed aluminum square handle
- Monolith stainless steel round handle
- Monolith brushed aluminum soft-edge handle
- Stainless steel Toe Kick
- Reverse door kit

See pages 34-35 for available accessories.

Product Dimensions

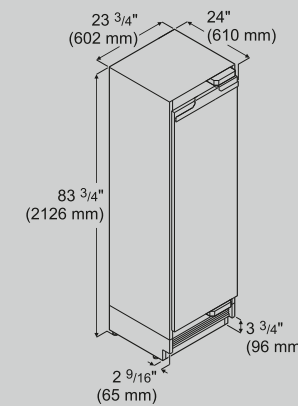

IMPORTANT!
Stated minimum height dimensions include when the leveled feet are fully inserted.

Height can be increased by a maximum of 1" (26 mm) by turning the adjustable feet. When the appliance is fitted in the recess, the appliance must be raised by turning the adjustable feet so that the appliance top has contact with the anti-tipping bracket. This results in a 4" (102 mm) Toe Kick height.

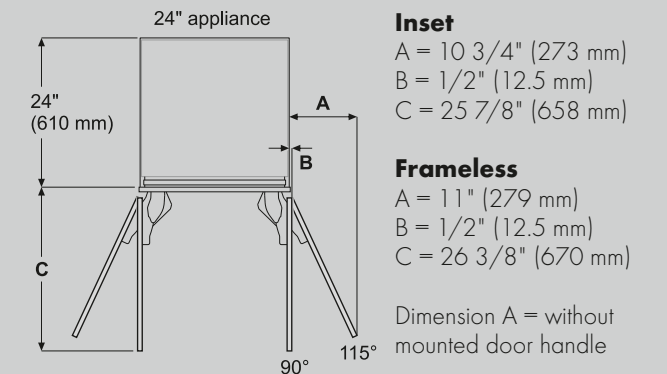

Cut out Dimensions

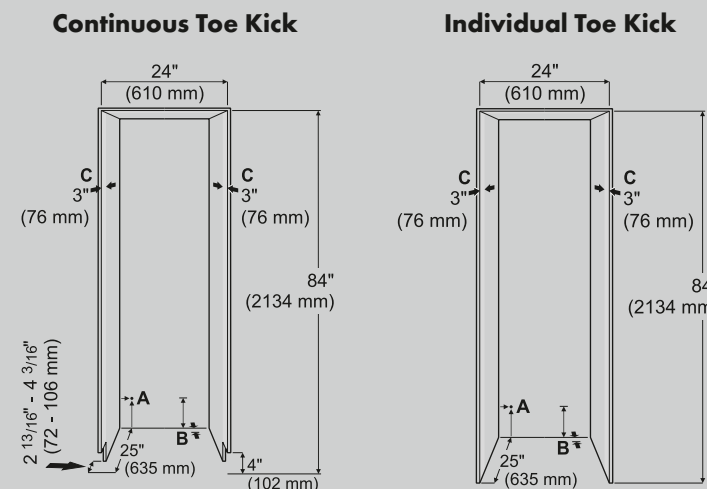

A
At this point the power cord exits from the appliance rear. 3/4" (19 mm) from the left and 5" (127 mm) from the floor. Free length of the power cord is 98" (2.5 m).

B
The appliance has a recess in this area for cable and waterline laying. 1" (25 mm) in depth and 5 1/2" (140 mm) in height over the whole width of the appliance.

C
This surface is visible when the appliance door is open. Designed finish is required.

Door Panel Dimensions

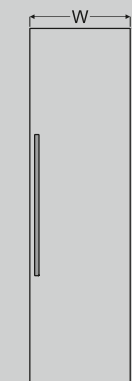

24" recess

Inset installation style

H = 79 7/8" (2029 mm)
W = 23 3/4" (603 mm)

Frameless installation style

H = 80" (2032 mm) Add overlapping dimension to the panel on the top.
W = 24" (610 mm) Add overlapping dimension to the panel on both sides.

Maximum panel weight = 52 lbs. (24 kg)

30" Monolith Freezer



◀30"▶

MF 3051	
Energy consumption (kWh/y)	529
Estimated Yearly Energy Cost in US \$	64*
Sound rating dB(A)	39**
Freezer capacity cu.ft. (l)	15.2 (431)
Number of shelves	4
Number of door racks	3
Number of FrostSafe drawers	3
Electronic control	InfinitySwipe
Freezer temperature range °F (°C)	+7 °F to -17 °F (-14 °C to -27 °C)
Defrost type	automatic
Interior light	InfinityLight
Water filter	yes
IceMaker	fixed water connection
Ice cube output lbs. (kg) / 24h	3.5 (1.6)
Ice cube stock lbs. (kg)	4.0 (1.8)
Door hinges	left, reversible***
Product dimensions	
in inch H/W/D	83 3/4" / 29 13/16" / 24"
in cm H/W/D	212.6 / 75.6 / 61
Cut out dimensions	
in inch H/W/D	84" / 30" / 25"
in cm H/W/D	213.4 / 76 / 63.5
Net weight lbs. (kg)	354.9 (161.0)
Voltage V/Hz	115/60

* Estimated energy cost will depend on utility rates and use. Estimated energy cost based on a national average electricity cost of 12 cents per kWh.

** Noise output – according to EN 60704-3.

*** Please contact your Liebherr Authorized Dealer for door reversal.

Available Accessories

- Stainless steel door panel
- Monolith brushed aluminum square handle
- Monolith stainless steel round handle
- Monolith brushed aluminum soft-edge handle
- Stainless steel Toe Kick
- Reverse door kit

See pages 34–35 for available accessories.

Product Dimensions

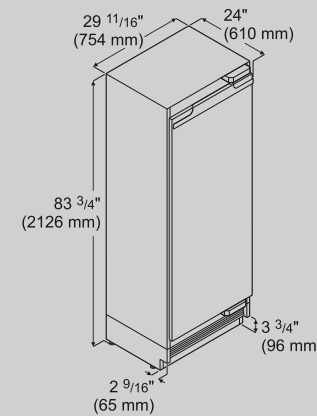

IMPORTANT!
Stated minimum height dimensions include when the leveled feet are fully inserted.

Height can be increased by a maximum of 1" (26 mm) by turning the adjustable feet. When the appliance is fitted in the recess, the appliance must be raised by turning the adjustable feet so that the appliance top has contact with the anti-tipping bracket. This results in a 4" (102 mm) Toe Kick height.

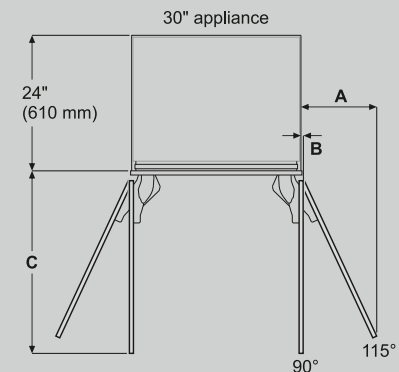

Inset
A = 13 1/4" (337 mm)
B = 1/2" (12.5 mm)
C = 31 7/8" (810 mm)

Frameless
A = 13 1/2" (343 mm)
B = 1/2" (12.5 mm)
C = 32 3/8" (822 mm)

Dimension A = without mounted door handle

Cut out Dimensions

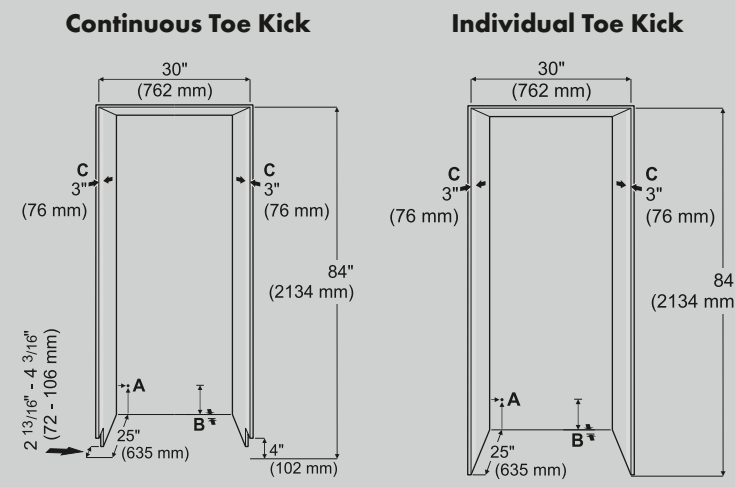

A
At this point the power cord exits from the appliance rear. 3/4" (19 mm) from the left and 5" (127 mm) from the floor. Free length of the power cord is 98" (2.5 m).

B
The appliance has a recess in this area for cable and waterline laying. 1" (25 mm) in depth and 5 1/2" (140 mm) in height over the whole width of the appliance.

C
This surface is visible when the appliance door is open. Designed finish is required.

Door Panel Dimensions

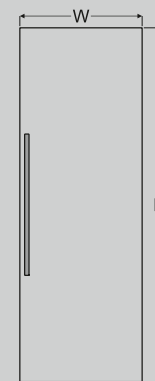

30" recess

Inset installation style

H = 79 7/8" (2029 mm)
W = 29 3/4" (756 mm)

Frameless installation style

H = 80" (2032 mm) Add overlapping dimension to the panel on the top.
W = 30" (762 mm) Add overlapping dimension to the panel on both sides.

Maximum panel weight = 66 lbs. (30 kg)

36" Monolith Freezer



◀36"▶

MF 3651	
Energy consumption (kWh/y)	586
Estimated Yearly Energy Cost in US \$	71 *
Sound rating dB(A)	39**
Freezer capacity cu.ft. (l)	18.9 (534)
Number of shelves	4
Number of door racks	3
Number of FrostSafe drawers	3
Electronic control	InfinitySwipe
Freezer temperature range °F (°C)	+7 °F to -17 °F (-14 °C to -27 °C)
Defrost type	automatic
Interior light	InfinityLight
Water filter	yes
IceMaker	fixed water connection
Ice cube output lbs. (kg) / 24h	3.5 (1.6)
Ice cube stock lbs. (kg)	4.0 (1.8)
Door hinges	left, reversible***
Product dimensions	
in inch H/W/D	83 3/4" / 35 13/16" / 24"
in cm H/W/D	212.6 / 90.9 / 61
Cut out dimensions	
in inch H/W/D	84" / 36" / 25"
in cm H/W/D	213.4 / 91 / 63.5
Net weight lbs. (kg)	385.8 (175.0)
Voltage V/Hz	115/60

* Estimated energy cost will depend on utility rates and use. Estimated energy cost based on a national average electricity cost of 12 cents per kWh.
 ** Noise output – according to EN 60704-3.
 *** Please contact your Liebherr Authorized Dealer for door reversal.

Available Accessories

- Stainless steel door panel
- Monolith brushed aluminum square handle
- Monolith stainless steel round handle
- Monolith brushed aluminum soft-edge handle
- Stainless steel Toe Kick
- Reverse door kit

See pages 34–35 for available accessories.

Product Dimensions

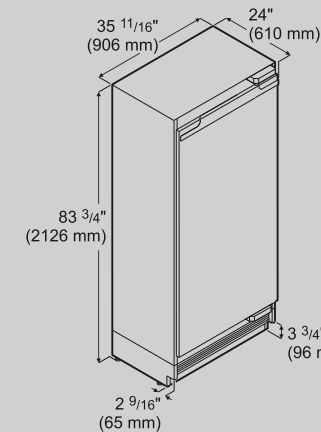

IMPORTANT!
 Stated minimum height dimensions include when the leveled feet are fully inserted.

Height can be increased by a maximum of 1" (26 mm) by turning the adjustable feet. When the appliance is fitted in the recess, the appliance must be raised by turning the adjustable feet so that the appliance top has contact with the anti-tipping bracket. This results in a 4" (102 mm) Toe Kick height.

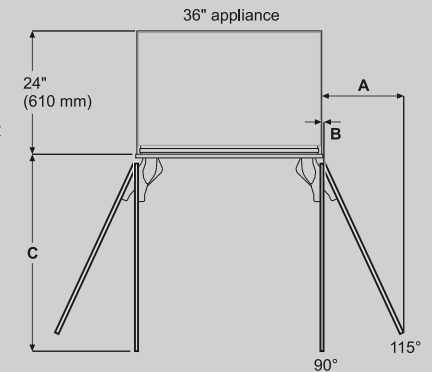

Inset
 A = 15 3/4" (400 mm)
 B = 1/2" (12.5 mm)
 C = 37 7/8" (962 mm)

Frameless
 A = 16" (416 mm)
 B = 1/2" (12.5 mm)
 C = 38 3/8" (975 mm)

Dimension A = without mounted door handle

Cut out Dimensions

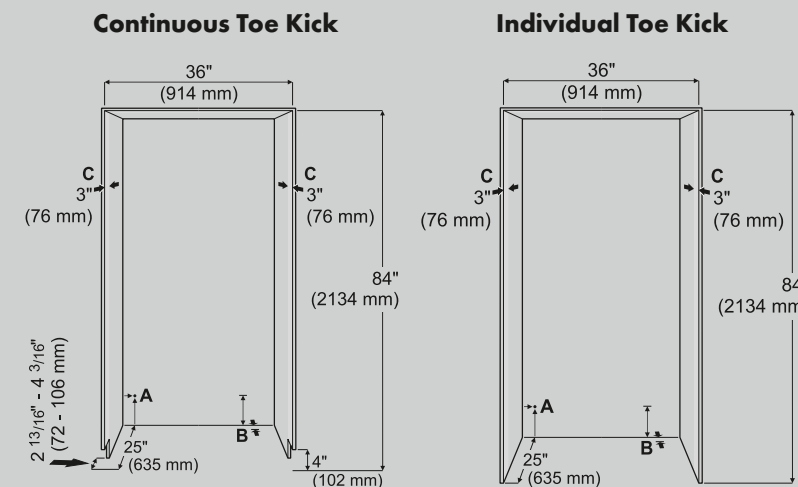

A
 At this point the power cord exits from the appliance rear. 3/4" (19 mm) from the left and 5" (127 mm) from the floor. Free length of the power cord is 98" (2.5 m).

B
 The appliance has a recess in this area for cable and waterline laying. 1" (25 mm) in depth and 5 1/2" (140 mm) in height over the whole width of the appliance.

C
 This surface is visible when the appliance door is open. Designed finish is required.

Door Panel Dimensions

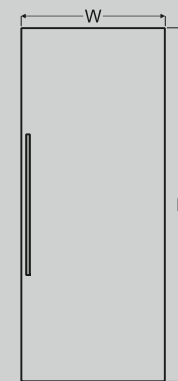

36" recess

Inset installation style

H = 79 7/8" (2029 mm)
 W = 35 3/4" (908 mm)

Frameless installation style

H = 80" (2032 mm) Add overlapping dimension to the panel on the top.
 W = 36" (914 mm) Add overlapping dimension to the panel on both sides.

Maximum panel weight = 88 lbs. (40 kg)

Monolith Accessories

01 Stainless steel Door Panel

18"	9901 916
24"	9901 883
30"	9901 872
36"	9901 458

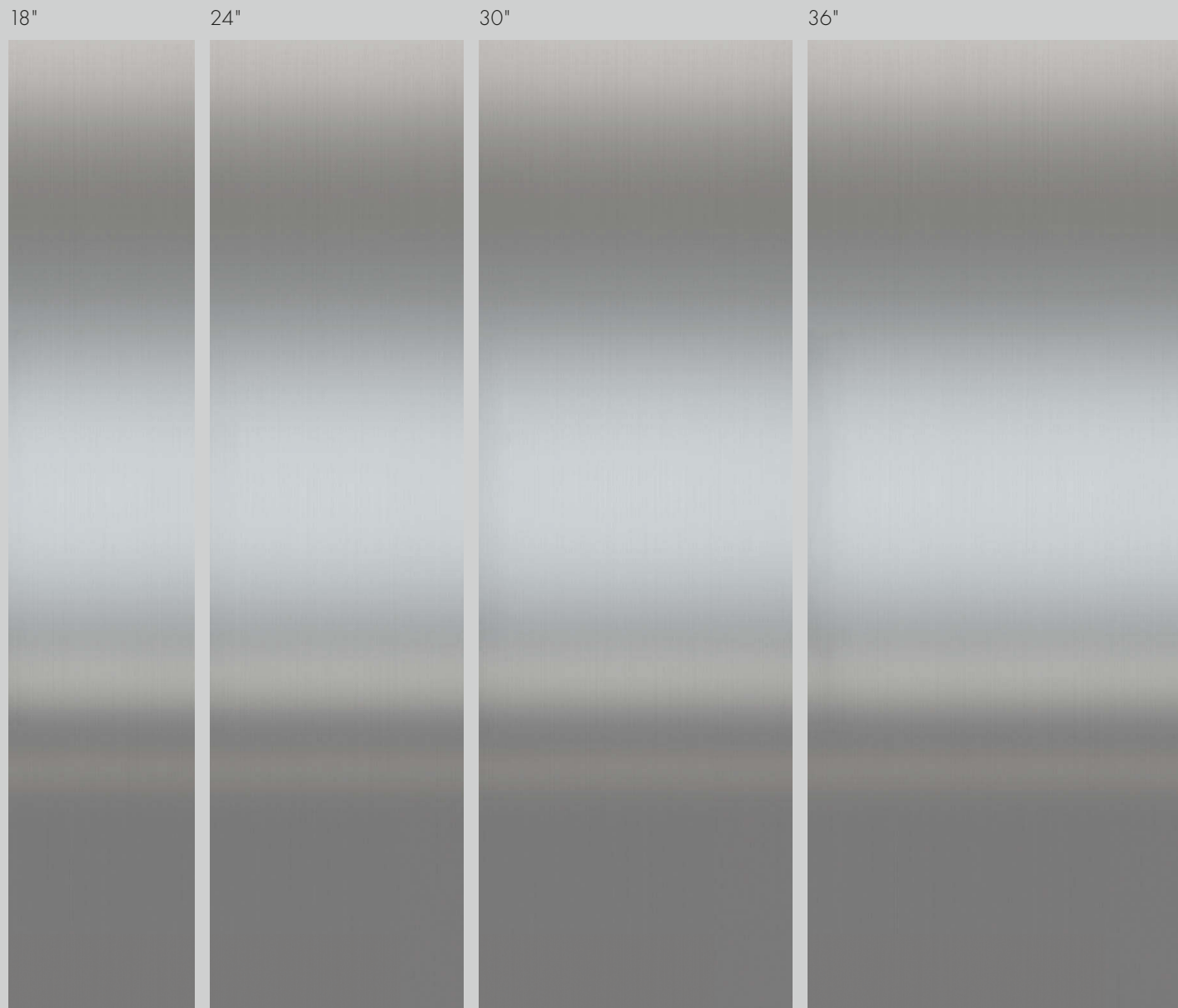

02 Monolith brushed aluminum square handle

Fastening screws are provided. The distance between the two screw holes is 30 5/16" (770 mm).

Available for all Monolith models 9901 461

03 Monolith brushed aluminum soft-edge handle

Fastening screws are provided. The distance between the two screw holes is 30 5/16" (770 mm).

Available for all Monolith models 9901 492

04 Monolith stainless steel round handle

Fastening screws are provided. The distance between the two screw holes is 30 5/16" (770 mm).

Available for all Monolith models 9901 489



05 Stainless steel Toe Kick

18"	9901 493
24"	9901 496
30"	9901 530
36"	9902 349

42"	9901 552
48"	9901 765
54"	9901 787
60"	9902 366
72"	9902 390



06 Side-by-Side kit

The Side-by-Side kit includes a side wall heater to prevent condensation, metal brackets with screws, and a finishing strip to fill the gap between the appliances.

Available for all Monolith models 9901 428

07 Reverse door kit

The reverse door kit includes the parts needed and instructions to reverse the door depending on the model from left to right or right to left.

Available for all Monolith models 9902 399

Planning Information

Area Requirements

Verify the following:

- Floors can support appliance's weight plus approximately 1200 pounds (544 kg) of food weight.
- Finished kitchen floor height is level. Refrigerator must be shimmed to the floor level or leveled to make sure air vents are not obstructed.
- Remove anything attached to the rear or side walls that can obstruct appliance opening.
- Cut out dimensions are accurate.
- Electrical outlet is in correct location.

Do not install this unit next to any other refrigerator or freezer except another Liebherr model. Liebherr models are designed to allow for Side-by-Side installation. They are equipped with a heating system to eliminate condensation when units are installed Side-by-Side. Installing this unit next to any other refrigerator or freezer can cause condensation or cause damage to the Liebherr unit.

IMPORTANT

To protect the refrigerator from possible damage, allow the appliance to stand 1 hour in place before turning the electricity on. This allows the refrigerant and lubrication system to reach equilibrium.

Blocking For Safety

The anti-tipping bracket must be installed to prevent the unit from tipping after it is installed. Refer to chapter "Blocking For Safety" in the installation instructions.

Safety Regulations

The appliances are designed to cool, freeze, store food as well as make ice (if equipped).

The appliances are manufactured to operate within specific ambient temperature limits according to its climate rating.

The climate rating indicates the ambient temperature at which the appliance may be operated in order to deliver optimal refrigeration performance.

The climate rating for Monolith columns is SN-T.

Climate Rating	Ambient Temperature
SN	50 °F to 90 °F (10 °C to 32 °C)
N	61 °F to 90 °F (16 °C to 32 °C)
ST	61 °F to 100 °F (16 °C to 38 °C)
T	61 °F to 109 °F (16 °C to 43 °C)
SN-ST	50 °F to 100 °F (10 °C to 38 °C)
SN-T	50 °F to 109 °F (10 °C to 43 °C)

IMPORTANT

Do not operate the appliance outside the specified ambient temperature range.

- Refrigerant circuits are tested for leaks.
- The appliances complies with current safety regulations

CAN/CSA C22.2 No.60335-1-11
 UL 60335-1 Fifth Edition
 CAN/CSA C22.2 No. 60335-2-24-06
 UL 60335-2-24 First Edition

Electrical Requirements & Safety

A 15 amp or 20 amp, 110-120 VAC, circuit which is grounded and protected by a circuit breaker or fuse is required.

We recommend using a dedicated circuit for each appliance to prevent circuit overload and the chance of interruption to the appliance.

The appliances are equipped with a three-prong (grounding) polarized plug for protection against possible shock hazards.

The power plug must be easily accessible so that the appliance can be disconnected quickly in an emergency. It should not be behind the appliance. In case the plug must be located behind the appliance, we recommend the receptacle located a maximum of 6" from the floor.

Comply with the National Electrical Code as well as local codes and ordinances when installing the receptacle.

⚠ WARNING!

Electrocution hazard.

Electrical grounding required.

- Do not remove the round grounding prong from the plug.
- Do not use extension cords or ungrounded (two-prong) adapters.
- Do not use a power cord that is frayed or damaged.
- Do not use a power strip.

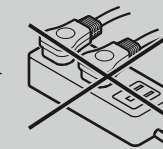
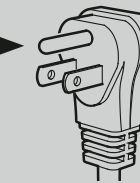

Failure to follow these instructions may result in fire, electrical shock or death.

⚠ WARNING!

The refrigerant R600a contained within the appliances is environmentally friendly, but flammable. Leaking refrigerant can ignite.

To prevent possible ignition, designed ventilation is required.

Internal Water Dispenser and IceMaker (if equipped)

Monolith appliances that are equipped with an internal water dispenser or an IceMaker must be connected to a water supply.

The water supply pressure requirements are different based on whether or not the supplied Liebherr water filter is installed. With the filter installed, the pressure must be in the range of 40-90 psi (2.8-6.2 bar). Without the filter installed the acceptable pressure range is 22-87 psi (1.5-6 bar).

Use a braided style IceMaker hose with 1/4" compression end or a 1/4" OD copper line to connect the water supply with the solenoid valve of the appliance. This is not supplied with the appliance.

If you have hard water, we recommend you install a water softener. Also, a filter must be installed if the water contains solids such as sand.

All equipment and devices used to supply the water to the appliance must comply with the current regulations for your geographical area.

All models equipped with an internal water dispenser or IceMaker include a water filter located in the front base of the product. Water filters must be replaced periodically. An alarm in the InfinitySwipe will indicate when the water filter must be replaced.

Safety Instructions and Warnings

- Do not attach the water source while the appliance is connected to an electrical outlet.
- A shut-off valve must be installed between the hose line and the main water supply so that the water supply can be stopped if necessary. Do not install the shut-off valve behind the appliance.
- The connection to the water supply may only be made by a trained and licensed plumber.
- The water quality must comply with the drinking water regulations for the geographical area where the appliance is located.
- The IceMaker is designed exclusively to make ice cubes in quantities needed by a household, and may only be operated with water appropriate for this purpose.
- All repairs and work on the IceMaker may only be done by Customer Service personnel or other trained personnel.
- The manufacturer cannot accept liability for damage caused by equipment or water lines between the solenoid valve and the water supply.

Installation Dimensions

When planning the cut out, it is essential that the top and side interior walls be flush to the appliance at a minimum depth of 4" (102 mm) from the outer edge of the face frame and composed of thick (5/8" (16 mm) minimum) material for secure installation. Also, because the case interior will be partially visible when the refrigerator door is opened, always ensure that the top and side returns are finished to match the exterior furniture at the same minimum depth of 4" (102 mm).

Monolith columns include a sealing set in order to cleanly close the gaps between appliance and cabinet side walls.

Monolith columns are designed to be fully flush integrated when installed in 25" (635 mm) deep cabinets, by using the stainless steel panels offered as accessories, or custom door panels that perfectly match the rest of kitchen cabinetry.

The typical wood panel thickness is 3/4" (19 mm), however thicker panels or other materials can be used. When using custom panels, always ensure that the panel reverse is finished to match the exterior, as parts of the panel reverse will be visible when the refrigerator door is opened.

When using custom panels, do not exceed the maximum panel weight allowed by the door hinge of the specific column.

Monolith columns are designed to fit any type of kitchen cabinetry door installation, whether 25" depth as the typical North America style, or the 24" depth known as European style.

The depth of the Monolith columns is 24" (610 mm), which allows for the appliances to be installed in an European style kitchen cabinetry which requires 24" (610 mm) and also a 25" (635 mm) deeper cut out to accommodate different types of installation like standard overlay, full overlay, offset or flush inset installation.

The cut out is the niche in which a Monolith column is installed. The width of the cut out can be the one of a single column (18", 24", 30", etc.) or the one for a Side-by-Side combination (42", 48", 54", etc.), this will depend on the column models considered.

In the North American style cabinetry, the total depth of the cut out is equal to the depth of the niche plus the face frame. It does not necessarily include the thickness of the door panel, as this will depend on the installation style.

For a standard overlay on an American style cabinet and frameless installation in European style cabinet, use the door panel dimension specified as frameless installation.

For a flush inset installation, use the door panel dimensions of inset installation.

For any other type of installation, please refer to Door Clearance Requirements (page 43) to define the door panel dimensions.

Door Panel Dimensions

Model	H	W	H	W	Max. panel weight
	Inset installation style	Inset installation style	Frameless installation style	Frameless installation style	
MRB 2400	79 7/8" (2029 mm)	23 3/4" (603 mm)	80" ¹ (2032 mm)	24" ² (610 mm)	52 lbs. (24 kg)
MRB 3000	79 7/8" (2029 mm)	29 3/4" (756 mm)	80" ¹ (2032 mm)	30" ² (762 mm)	66 lbs. (30 kg)
MRB 3600	79 7/8" (2029 mm)	35 3/4" (908 mm)	80" ¹ (2032 mm)	36" ² (914 mm)	88 lbs. (40 kg)
MF 1851	79 7/8" (2029 mm)	17 3/4" (451 mm)	80" ¹ (2032 mm)	18" ² (457 mm)	40 lbs. (18 kg)
MF 2451	79 7/8" (2029 mm)	23 3/4" (603 mm)	80" ¹ (2032 mm)	24" ² (610 mm)	52 lbs. (24 kg)
MF 3051	79 7/8" (2029 mm)	29 3/4" (756 mm)	80" ¹ (2032 mm)	30" ² (762 mm)	66 lbs. (30 kg)
MF 3651	79 7/8" (2029 mm)	35 3/4" (908 mm)	80" ¹ (2032 mm)	36" ² (914 mm)	88 lbs. (40 kg)

¹ Not considering overlapping of the panel at the top.

² Not considering overlapping of the panel to the right and left.

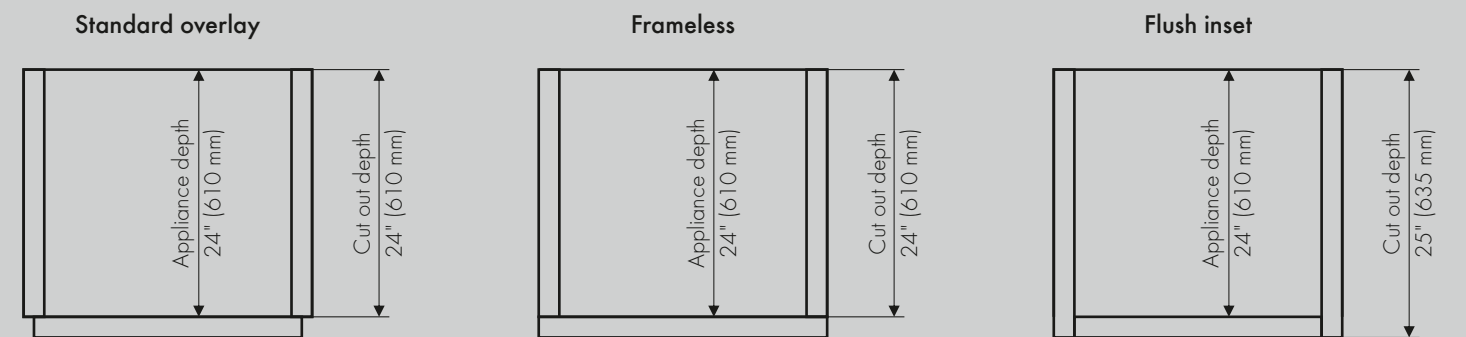

Installation Options

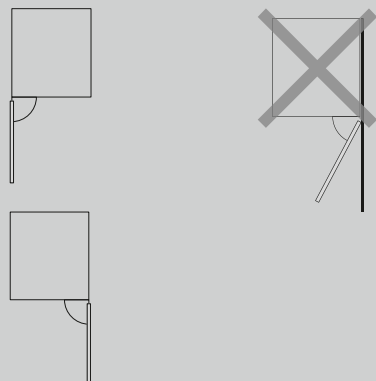
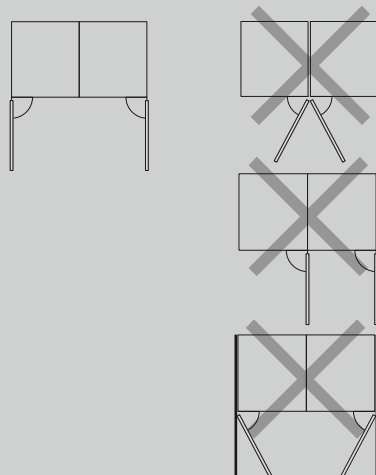
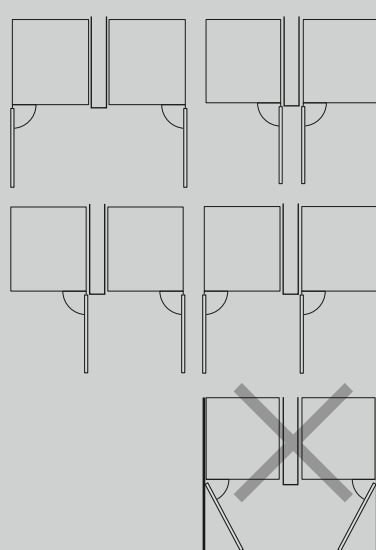
Recommended Installations	Considerations
<p>Stand-alone</p> 	<p>All Monolith appliances can be installed as a left-hinge or right-hinge stand-alone unit. When dimensioning the cabinet, include the thickness of the door panel and handle (see page 43, Door Clearance Requirements).</p> <p>Ensure the Monolith appliance is installed so the door has clearance from any adjacent wall or any kitchen element.</p>
<p>Side-by-Side within one cabinet</p> 	<p>Monolith appliances can be installed Side-by-Side within one cabinet by installing a Side-by-Side kit, which must be purchased separately. When dimensioning the cabinet, include the thickness of the door panel and handle (see page 43, Door Clearance Requirements).</p> <p>During design and installation, please take into account the layout of left and right hinged appliances without the risk of door opening collision.</p> <p>Ensure that the Monolith appliances are installed in such a way that the doors do not interfere with any adjacent wall or any kitchen element.</p>
<p>Side-by-Side within separate cabinets</p> 	<p>Monolith appliances can be installed Side-by-Side within separate cabinets. If the panel between the cabinet is less than 3/4" (19 mm) a Side-by-Side heater kit is required. The heater must be ordered separately.</p> <p>When dimensioning the cabinet, include the thickness of the door panel and handle, in order to prevent any door opening collision (see page 43, Door Clearance Requirements).</p> <p>A minimum partition of 6" (154 mm) width is required to ensure that handles to not collide when doors are opened centered towards each other or facing each other.</p> <p>Ensure that the Monolith appliances are installed so the doors have clearance from any adjacent wall or kitchen element.</p>

Side-by-Side Installation

The cut out width for the Side-by-Side combinations is defined by adding the single width of each of the models considered in the combination. Below you can find the cut outs for 42", 48", 54", 60" and 72" niches.

Cut out dimensions for individual Toe Kick

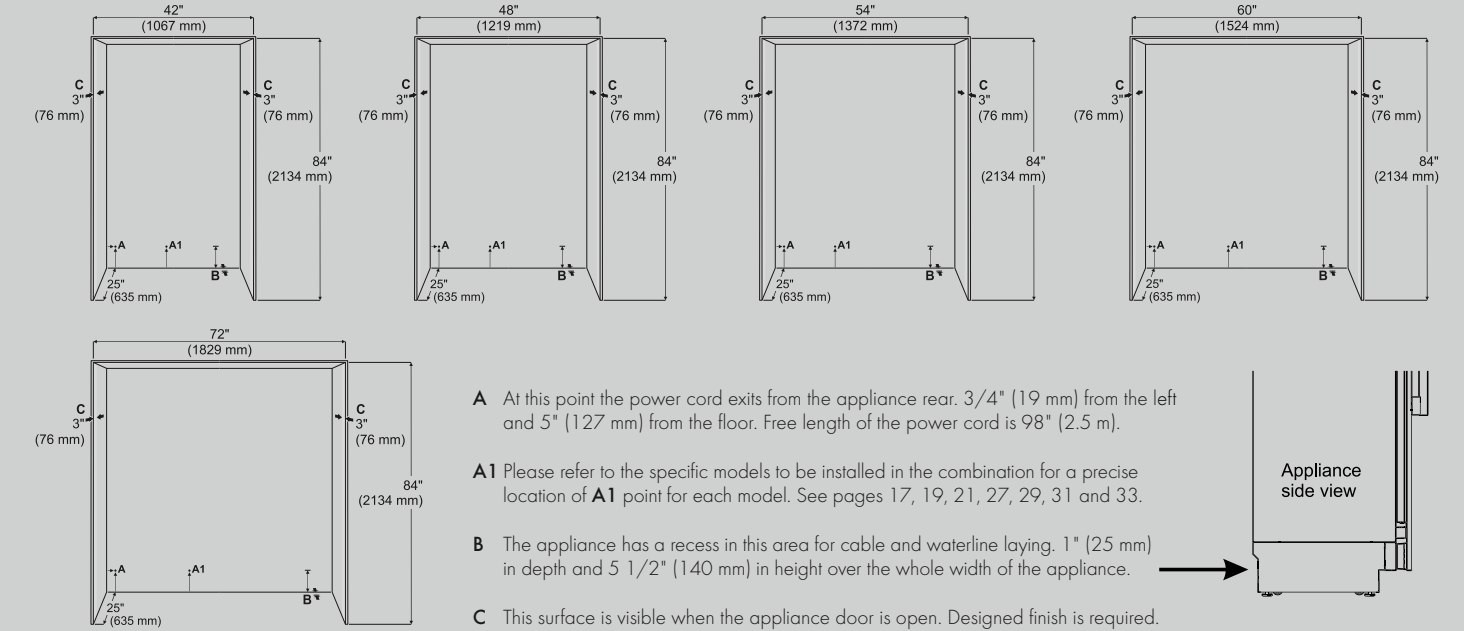

Cut out dimensions for continuous Toe Kick along the wall

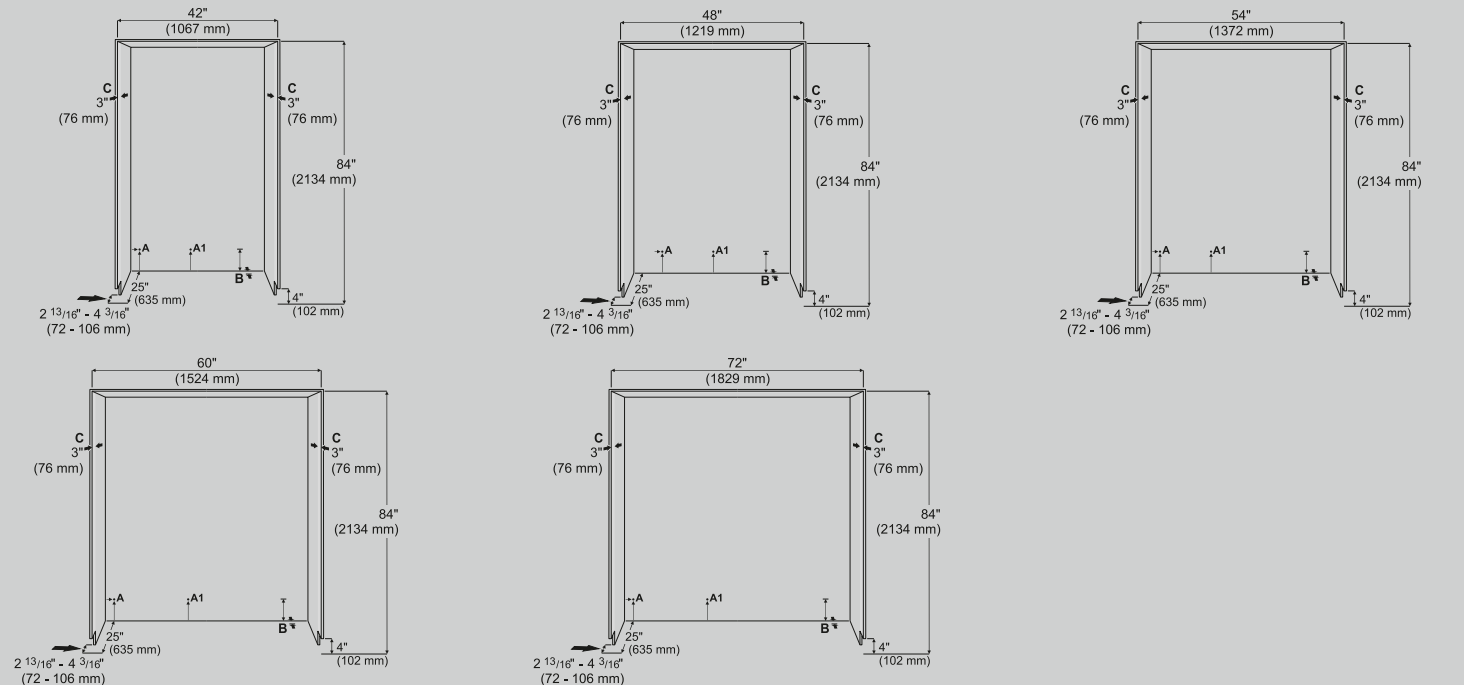

Toe Kick and Ventilation Requirements

All Monolith ventilation takes place through the Toe Kick area. Door panels must be a minimum of 4" above the floor. Do not block grill in Toe Kick area.

Liebherr offers a 4" (102 mm) tall Toe Kick matching the width of the Monolith columns, and possible Side-by-Side combinations, as an accessory. Please refer to page 35 for Toe Kick accessories ranging from 18" to 72" width.

The Monolith appliance comes with dividers that must be installed on the appliance and onto the door, in order to separate the warm exhaust air from the fresh incoming air.



Door Clearance Requirements

It is fundamental that the Monolith appliances are installed so the doors (including handles) and adjacent cabinets, countertops, walls, or other kitchen elements do not collide with one another when doors open.

In case the door hits the wall or other cabinetry, a door limiter of 90° is available, please contact an authorized Liebherr service provider.

Additional solutions include:

- Reduce the door panel thickness if it is larger than 3/4" (19 mm).
- Rearrange the element that is colliding with the appliance.
- Use a bumper or stopper to prevent the door from damaging the adjoining wall or cabinet.

Panel clearance
Frameless installation style
Panel thickness 3/4"
Top view

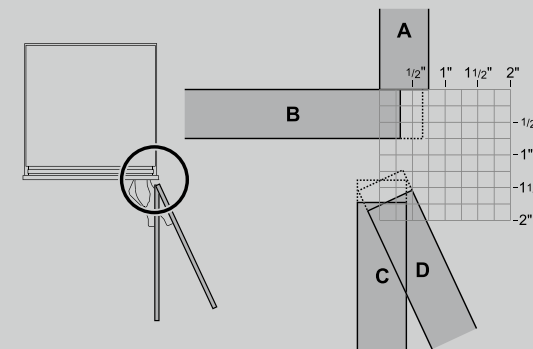

- A = 3/4" gable
- B = Front panel door closed. 5/16" (8 mm) overlapping.
Dash line shows an overlapping of 7/8" (22 mm).
This overlapping is solely if the appliance is at the end of a line of cabinets.
- C = Front panel 90°
- D = Front panel at max. door opening angle of 115°

IMPORTANT

The gap between the appliance front panel and the surrounding furniture panels must be at least 1/8" (3 mm).

Panel clearance
Panel thickness 3/4"
Top view

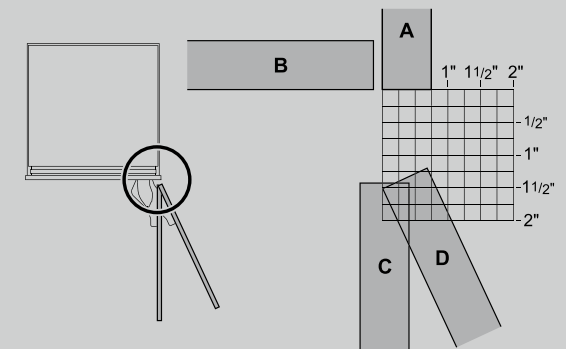

- A = Appliance housing
- B = Front panel door closed
- C = Front panel 90°
- D = Front panel at max. door opening angle of 115°

home.liebherr.com/monolith