

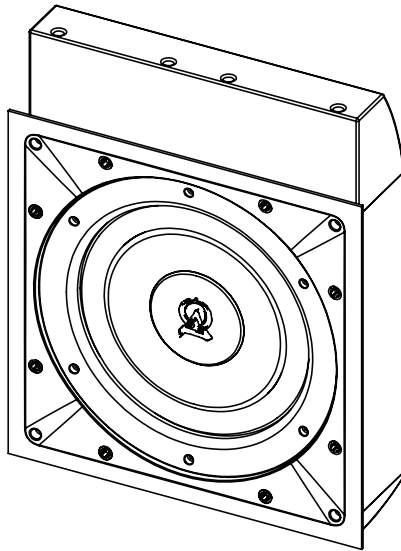

# CSUB10REX

EXPLORER COLLECTION™

IN-WALL SUBWOOFER | INSTALLATION MANUAL



# TABLE OF CONTENTS

1. Introduction	1
2. Specifications	2
3. CSUB10REX:	
- 3a. What's Included	2
- 3b. Required Tools/Items	
- 3c. About Speaker Wire	
- 3d. Installation Location	3
- 3e. Amplifier	
4. Installation:	4
-4a. Installing the wire	
- 4b. Cutting the Hole	
- 4c. Connecting The Wires	5
- 4d. Insert The Enclosure	
- 4e. Attach The Bezel	
- 4f. Mounting The Grille	6
5. Troubleshooting	7
6. Technical Assistance	8
7. Limited Lifetime Warranty	9
8. Return Process	10



## **1. Introduction**

Thank you for your purchase!

At Origin Acoustics, we take pride in providing you with a high quality product. All of Origin Acoustics' speakers are designed to have excellent sound quality, longevity, and a simple installation process.

The Explorer Collection of loudspeakers from Origin Acoustics were developed to withstand the harsh conditions found in marine environments. This includes exposure to saltwater, extreme temperature changes and airborne humidity. They will produce amazing musical fidelity while spending family time on the lake or a trip on the open sea and they have the build quality to last for years in these situations.

This instruction booklet covers the necessary information for a smooth installation, including: the tools you will need, step-by-step instructions for installation, troubleshooting tips for any errors that may occur, and all warranty information. If for any reason you experience problems or if you have installation questions please call us at (844) 674-4461. Hours of operation are 8:00am to 5:00pm (Pacific Time), Monday through Friday.

## 2. Specifications

Description: Retrofit In-Wall Subwoofer

MODEL	CSUB10REX
<b>PART</b>	<b>CSUB1000REX</b>
Woofers	10" Anodized Aluminum(254mm)
Grille Material	Aluminum
Frequency Response	30Hz-250Hz
Power Handling	100 - 500W
Impedance	8Ω
Sensitivity	88dB
Amplifier Requirements	SUBA500 / SUBA150
Cutout Dimensions	13" W x 13" H (330 x 330 mm)
Dimensions (Enclosure)	13" W x 17" H x 3.5" D (330 x 430 x 88 mm)
Grille Dimensions	14.375" L x 14.375" W (366 x 366 mm)

### 3a. CSUB10REX: What's Included

- Enclosure
- 4 x Screws
- Grille
- Bezel
- Hex Wrench

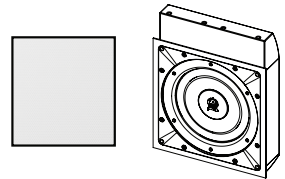

### 3b. Required Tools/Items

- Drywall Saw
- Speaker wire
- Tape measure
- Pencil
- Wire Stripper
- Drill
- Stiff Wire
- Stud Finder
- Fish Tape
- Spray Paint
- Compressed Air
- Drill Bit 1/8" (3mm)

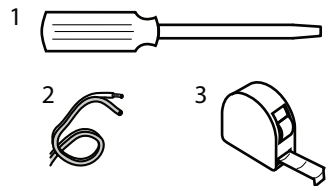

### **3c. Wire Recommendation**

You will need a wire that has at least two conductors; one that can be identified as the positive and the other as the negative. All two conductor wires have some means of identifying which conductor is which, but at times this identification may be subtle. It's crucial that you keep track of which wire you use for positive (+) and negative (-). Typically if the wires are colored red and black, the red wire is used for positive and the black wire is used for negative, but sometimes other colors or patterns are used. You can choose whichever color of wire you want to be positive and negative as long as you remain consistent throughout the install.

### **3d. Choosing the Installation Location**

The location of your subwoofer(s) will have a large impact on sound quality. For best results, install the subwoofer so the bottom is close to the ground and in either corner in the front of the room. If you're installing two subwoofers in the room, the best option is one in each corner in the front.

### **3e. Choosing the Amplifier**

This subwoofer has been designed to work with an Origin Subwoofer amplifier, either the SubA150 or the SubA500.

## **4. CSUB10REX: Installation**

### **4a) Installing the Wire**

Strip  $\frac{1}{4}$  to  $\frac{1}{2}$  inches (6 to 12 mm) of the insulation off both ends of the wire. To avoid stray strands, twist them at the end.

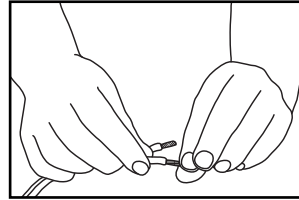
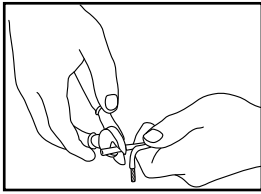

*Installing the Wire*

Connect both wires to the amplifier.

Plan how you'll route the wire to the desired speaker location. There are several methods for routing the wire and you may need to combine several of them.

#### **Under the Carpet:**

One option is to lift up the carpet and use tape wire to route the wire under the carpet.

#### **Behind the Baseboard:**

The wire can be routed behind the baseboard by cutting a groove out of the back of the baseboard, or by buying special baseboard designed for concealing wires.

#### **Through an Attic, Crawlspace or Basement:**

When available you can route the wire through an attic or crawlspace.

#### **Through walls:**

When running wires through a wall be sure to avoid all obstacles such as AC wiring, pipes, and ducts.

#### 4b) Cutting The Hole

When you've decided on the subwoofer's location, use the template to trace a rectangle lightly in pencil where the hole should be. If you're unsure on whether there may be obstacles (such as pipes or wires) where you plan on installing the speaker, drill a 1/8 inch hole in the center of the rectangle, then put a bent coat hanger through the hole to feel around. If there are no obstacles, use a keyhole or drywall saw to cut the hole.

#### 4c) Connecting The Speaker Wire

Push down on the top of the connector and insert the wire, making sure that the positive is being attached to the red connection and the negative is being attached to the black connection.

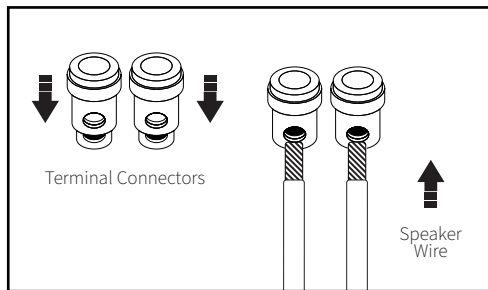

#### 4d) Insert the Enclosure

Hold the enclosure in front of and slightly below the hole. Insert the top of the enclosure and slide it up. Push the bottom into the hole, and slide the enclosure down until the lip is resting on the bottom of the hole. If the internal wall depth is greater than 3 1/2" you will need to place some foam rubber behind the enclosure to assure it won't fall back into the wall. The CSUB10R subwoofer depends on the lip resting on the bottom of the square hole until the bezel is attached.

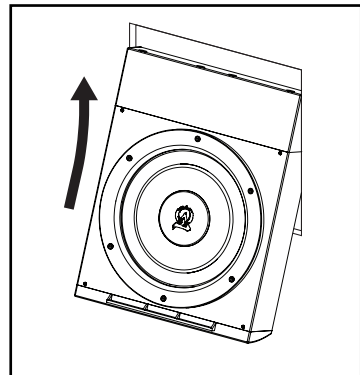

#### 4e) Attach the Bezel

Only one side of the bezel will nest onto the lip that is holding the enclosure in place. Once the bezel is positioned properly, screw it in place four screws and the supplied hex wrench. Make sure the screws are snug but use care to not overtighten.

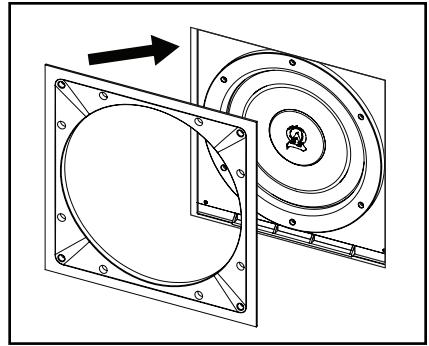

**Silicone Sealant:** In all applications where moisture is a concern, care should be taken to completely seal the subwoofer to the installation surface (Outer Border 'A'). It is strongly recommended that a liberal bead of marine grade silicone sealant be applied in this area. This will improve weather resistance and also assure that mechanical vibrations, like those common in watercraft, will not dislodge the loudspeaker.

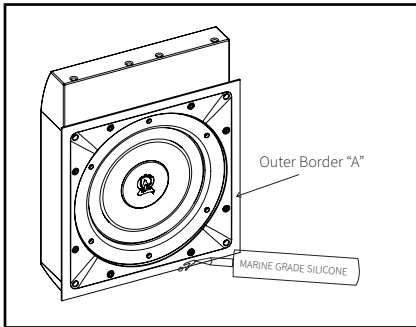

#### 4f) Mounting the Grille

Line up the pegs on the grille with the peg holes on the front of the bezel and push the grille into place.

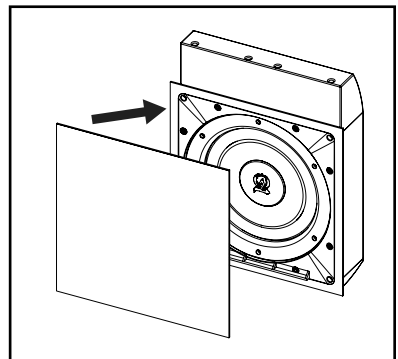



## 5. Troubleshooting

If possible, it's often good to try to isolate the problem first. For example, if you're playing a DVD on a television and there's no sound, try connecting an MP3 player to the system to see if that works. If it does work, then the problem is with the television, DVD player, or the cables connecting them. If it doesn't work, the problem will be with the amplifier, speakers, or those cables.

Problem	Possible Cause
No Sound	The volume may be turned down or muted. Check the volume settings on both the amplifier and the television/computer/CD player/etc.
No Sound	Make sure the proper source is selected on the amplifier or receiver.
No Sound	Check the cord connecting the amplifier with the source. The cord may be damaged or plugged into the wrong input or output.
No Sound	Check the wires connecting the amplifier with the speakers. Make sure they're connected properly and not damaged in any way.
Poor Sound Quality	If you hear something like static, or the sound is cutting in and out, check the audio cables. If the problem increases when a cable is being moved, then the cable is most likely faulty or not connected properly.
Poor Sound Quality	Today's audio systems may have several places to adjust the volume, for example your MP3 player may have a volume control, and your amplifier may also have one. Check to be certain that the volume isn't turned up past 80% on any device.
Poor Sound Quality	Try changing sources to be certain that the selection you've chosen is a good quality recording.

## **6. Technical Assistance**

If you have any questions or concerns about installing or using this product, you can reach us through one of the following methods:

**Phone:** (844) 674-4461

**Hours of operation:** 8:00am - 5:00pm (Pacific Time), Mon - Fri

**Email:** [sales@originacoustics.com](mailto:sales@originacoustics.com)

If you are having technical trouble, please include the model number and briefly explain what steps you took to resolve the problem in your email, or be prepared to answer these questions over the phone. If you are considering returning the product, it's required that you contact Origin Acoustics prior to any return attempts. This way we can determine if the issue can be resolved without returning the product, or if needed we can provide instructions and support for the return process.

## **7. Limited Lifetime Warranty**

Origin Acoustics warrants to the original retail purchaser only that this Origin Acoustics product will be free from defects in materials and workmanship, provided the speaker was purchased from an Origin Acoustics authorized dealer.

If the product is determined to be defective, it will be repaired or replaced at Origin Acoustics' discretion. If the product must be replaced yet it is no longer manufactured, it will be replaced with a model of equal to or greater value that is the most similar to the original. If this is the case, installing the replacement model may require mounting modifications; Origin Acoustics will not be responsible for any such related costs.

### **Requirements & Warranty Coverage**

This warranty may not be valid if the product was purchased through an unauthorized dealer. This warranty only applies to the individual that made the original purchase, and it cannot be applied to other purchases. The purchaser must be prepared to provide proof of purchase (receipt). This warranty will not be valid if the identifying number or serial number has been removed, defaced, or altered.

**\*All warranties and warranty conditions are subject to change. Please refer to [www.originacoustics.com](http://www.originacoustics.com) for the latest information.**

## **Not Covered by Warranty**

- Accidental damage
- Damage caused by abuse or misuse
- Damage caused by attempted repairs/modifications by anyone other than Origin Acoustics or an authorized dealer
- Damage caused by improper installation
- Normal wear, maintenance, and environmental issues
- Damage caused by voltage inputs in excess of the rated maximum of the unit
- Damage inflicted during the return shipment

## **8. Return Process**

Before making any return attempts, it is required that you first contact Origin Acoustics. Return product to Origin Acoustics or your dealer, either in person or by mail. It's preferable if the product is returned in the original packaging. If this isn't possible, the customer is responsible for insuring the shipment for the full value of the product.

This warranty is in lieu of all other expressed or implied warranties. Some states do not allow limitations on implied warranties, so this may not apply depending on the customer's location. (For more information, see Magnuson-Moss Warranty Act.)



01-24-2022

6975 S Decatur BLVD, Las Vegas, NV 89118 • [www.originacoustics.com](http://www.originacoustics.com) • 844-674-4461

©2023 Origin Acoustics. All copyrighted, trademarked and patented elements mentioned herein are the sole property of Origin Acoustics.