

Assembly Instruction For Coffee Table CTMA100OT

Caution: Please read instructions thoroughly before unpacking assembly parts. Sharp, exposed staple tips can cause injury, therefore, for your protection, please remove any exposed staples used in packing.

1. We recommend that you should assemble this product with the assistance of another person; this will make assembly easier, and will help to eliminate damage to the product or injury to persons during assembly.
2. Be sure to check all packing materials carefully for small parts that may have come loose inside the carton during shipment.
3. Please do not over tighten screws or bolts.
4. Please put all parts on a non-abrasive floor before assembly, and follow the assembly steps to assemble your newly purchased product correctly and efficiently.

PART LIST			
NO.	PARTS DESC	CODE	Q'TY
A	Coffee Table-Top	PCTMA100CTTOP	1
B	Coffee Table-Leg Frame	PCTMA100CTLEG	2
C	Coffee Table-Shelf	PCTMA100CTSHF	1
D	Coffee Table-Apron	PCTMA100CTAPR	2

HARDWARE LIST			
NO.	HARDWARE DESC	CODE	Q'TY
1	 Allen Bolt (1/4 " x16mm)	PCTMA 100CTHW	8
2	 Allen Bolt (1/4 " x40mm)		10
3	 Spring washer		18
4	 Flat washer		18
5	 Allen Key M4		1

STEP 1

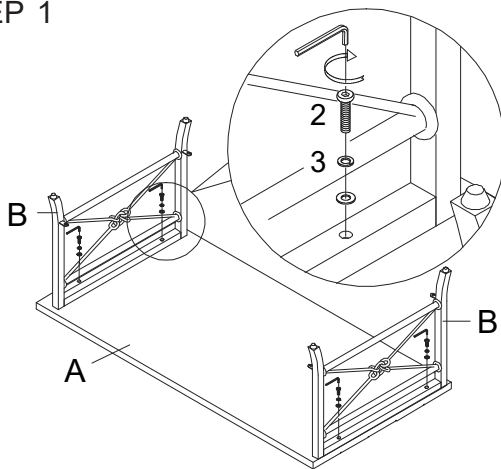

STEP 2

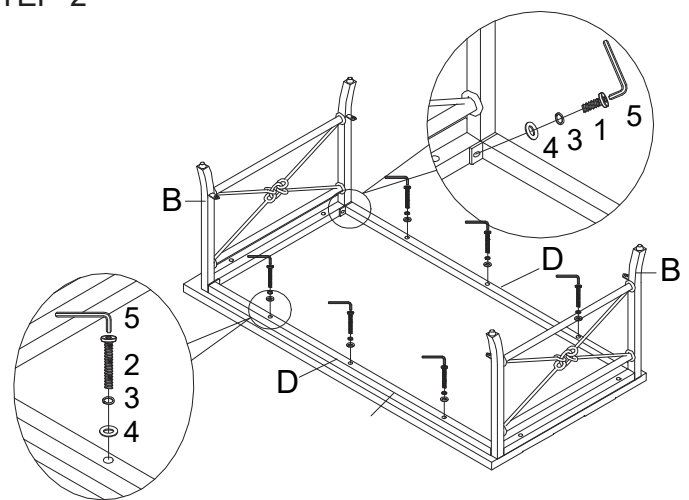

STEP 3

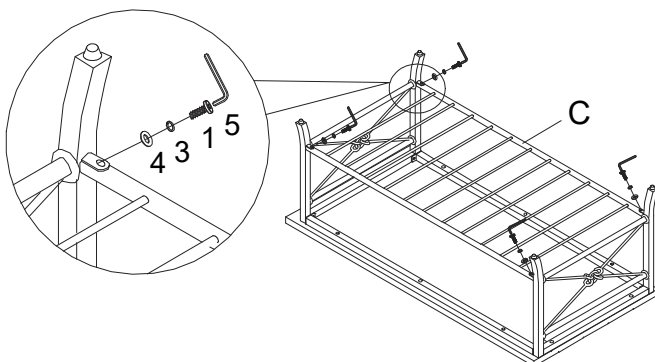

COMPLETED

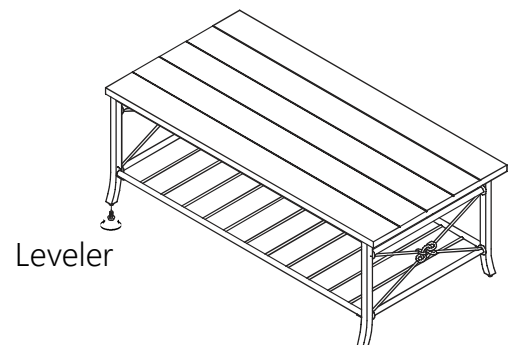

Assembly Instruction For End Table CTMA100OT

Caution: Please read instructions thoroughly before unpacking assembly parts. Sharp, exposed staple tips can cause injury, therefore, for your protection, please remove any exposed staples used in packing.

1. We recommend that you should assemble this product with the assistance of another person; this will make assembly easier, and will help to eliminate damage to the product or injury to persons during assembly.
2. Be sure to check all packing materials carefully for small parts that may have come loose inside the carton during shipment.
3. Please do not over tighten screws or bolts.
4. Please put all parts on a non-abrasive floor before assembly, and follow the assembly steps to assemble your newly purchased product correctly and efficiently.

PART LIST			
NO.	PARTS DESC	CODE	Q'TY
A	End Table-Top	PCTMA100ETTOP	1
B	End Table-Leg Frame	PCTMA100ETLEG	2
C	End Table-Shelf	PCTMA100ETSHF	1
D	End Table-Apron	PCTMA100ETAPR	2

HARDWARE LIST			
NO.	HARDWARE DESC	CODE	Q'TY
1	 Allen Bolt (1/4" x16mm)	PCTMA 100ETHW	8
2	 Allen Bolt (1/4" x40mm)		8
3	 Spring washer		16
4	 Flat washer		16

STEP 1

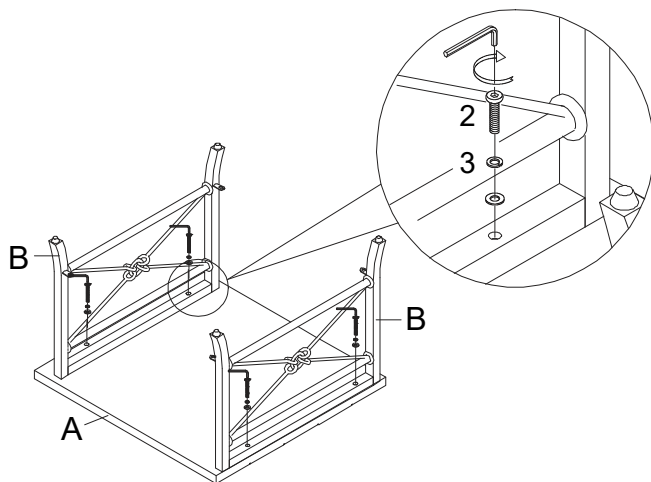

STEP 2

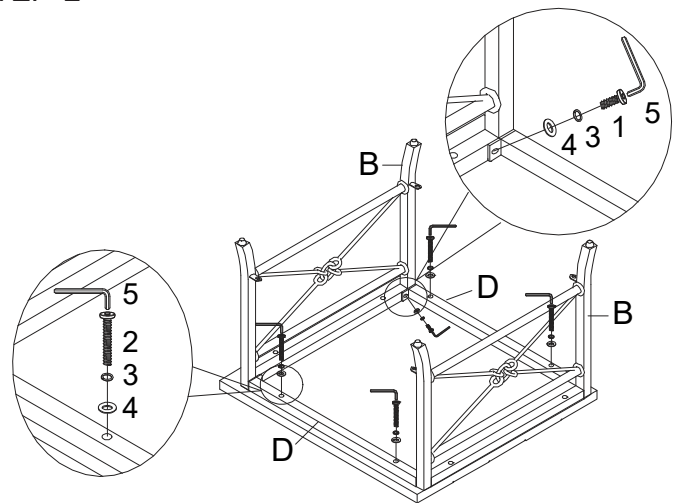

STEP 3

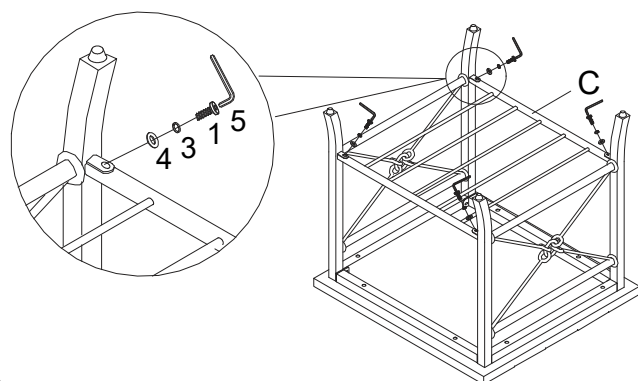

COMPLETED

