

Queen Headboard

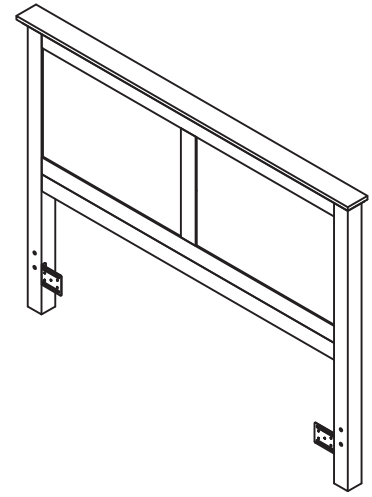

IMPORTANT

Carefully remove all the parts from the carton and place them individually on a soft cloth to prevent scratches or other damage.

Carefully and strictly follow these assembly instructions to ensure a completed product as designed.

Do not use power tools above 8 volts to assemble.

Part List

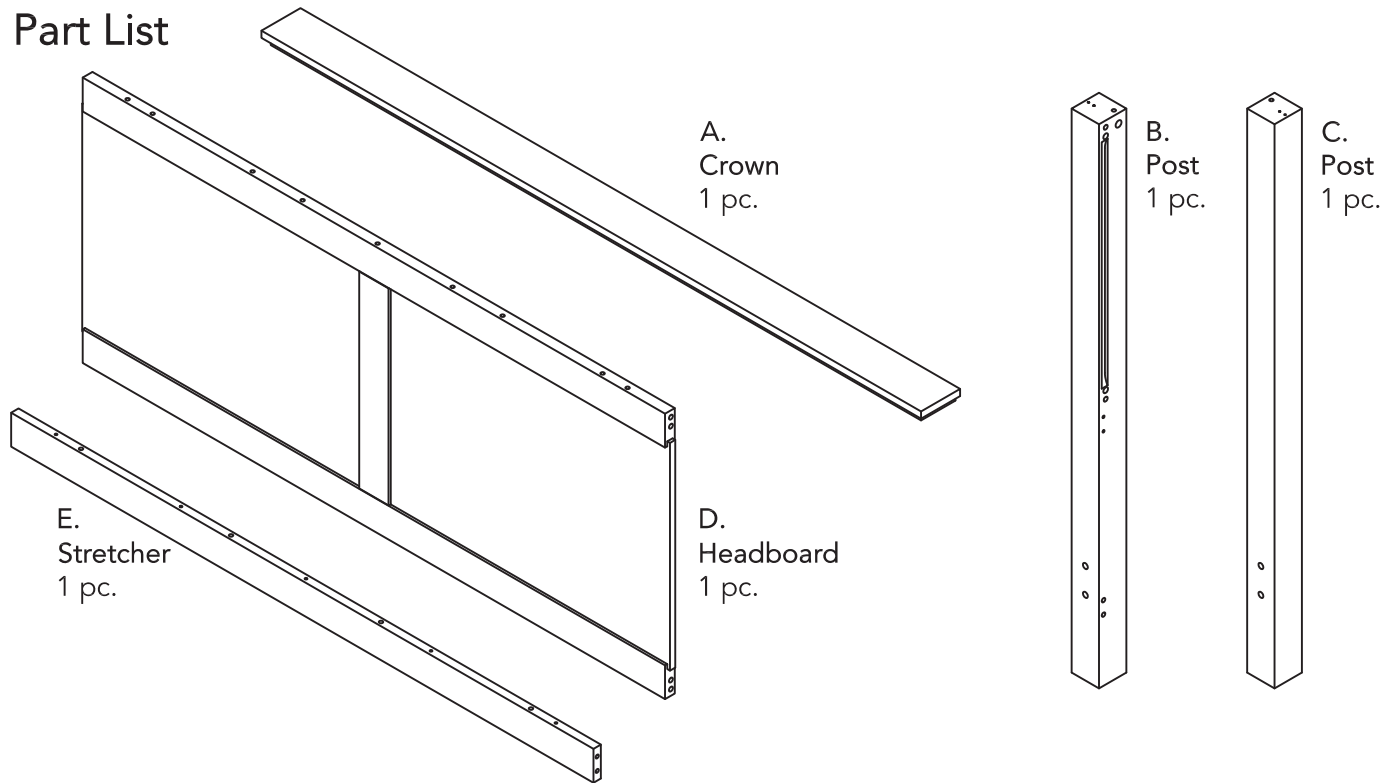

Hardware List



Cam Lock Screw
16 pcs. (+2 extra)



Cam Lock
16 pcs. (+2 extra)



Hex Wrench
1 pc.



Hex Wrench (small)
1 pc.



M6x20
Head Cap Bolt
4 pcs. (+1 extra)



Spring Washer
4 pcs. (+1 extra)



Flat Washer
4 pcs. (+1 extra)



Corner Plate
2 pcs.



Wrench
1 pc.



5/16" x 3 1/8"
Bolt
4 pcs. (+1 extra)



Square Washer
4 pcs. (+1 extra)



Nut
4 pcs. (+1 extra)



M3x16
5/8" Flat Head Screw
6 pcs. (+1 extra)



Plate
2 pcs.



Dowel (long)
4 pcs. (+1 extra)



Dowel (short)
8 pcs. (+1 extra)

Tool(s) required for assembly: Phillips screwdriver

homestyles Customer Service: www.homestylesfurniture.com,
servicedesk@homestylesfurniture.com, 888-680-7460

Assembly Instructions 2/6

IMPORTANT

- Use a soft cloth between these parts and the floor.
- Do not use power tools above 8 volts to assemble.
- Do not tighten all the bolts until each part is properly assembled.
- Keep Wrench and Hex Wrench as the Nuts and Head Cap Bolts may need to be tightened in the future.

STEP 1

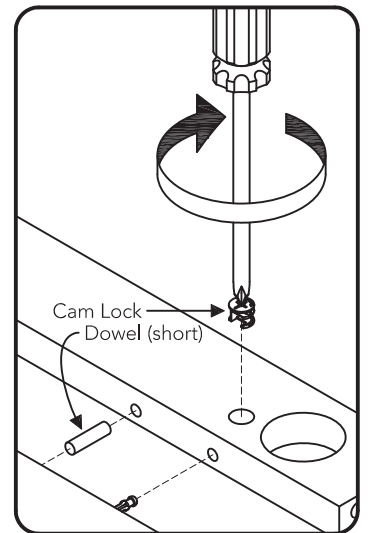
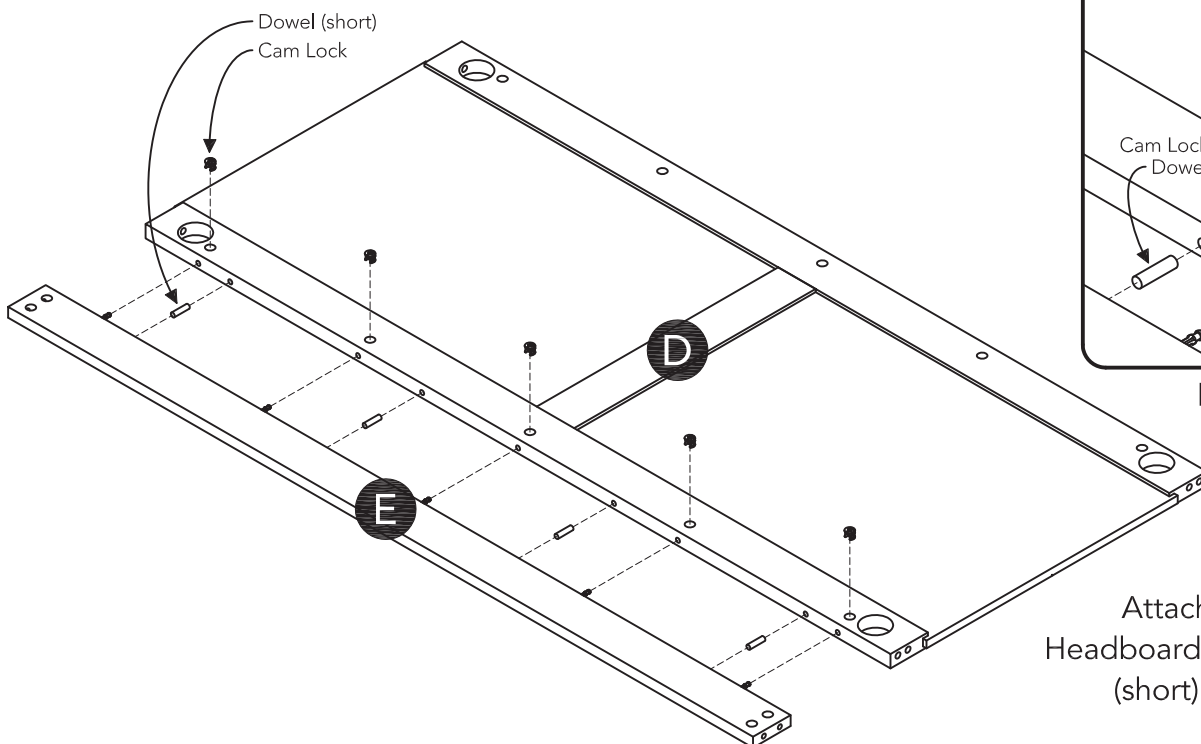
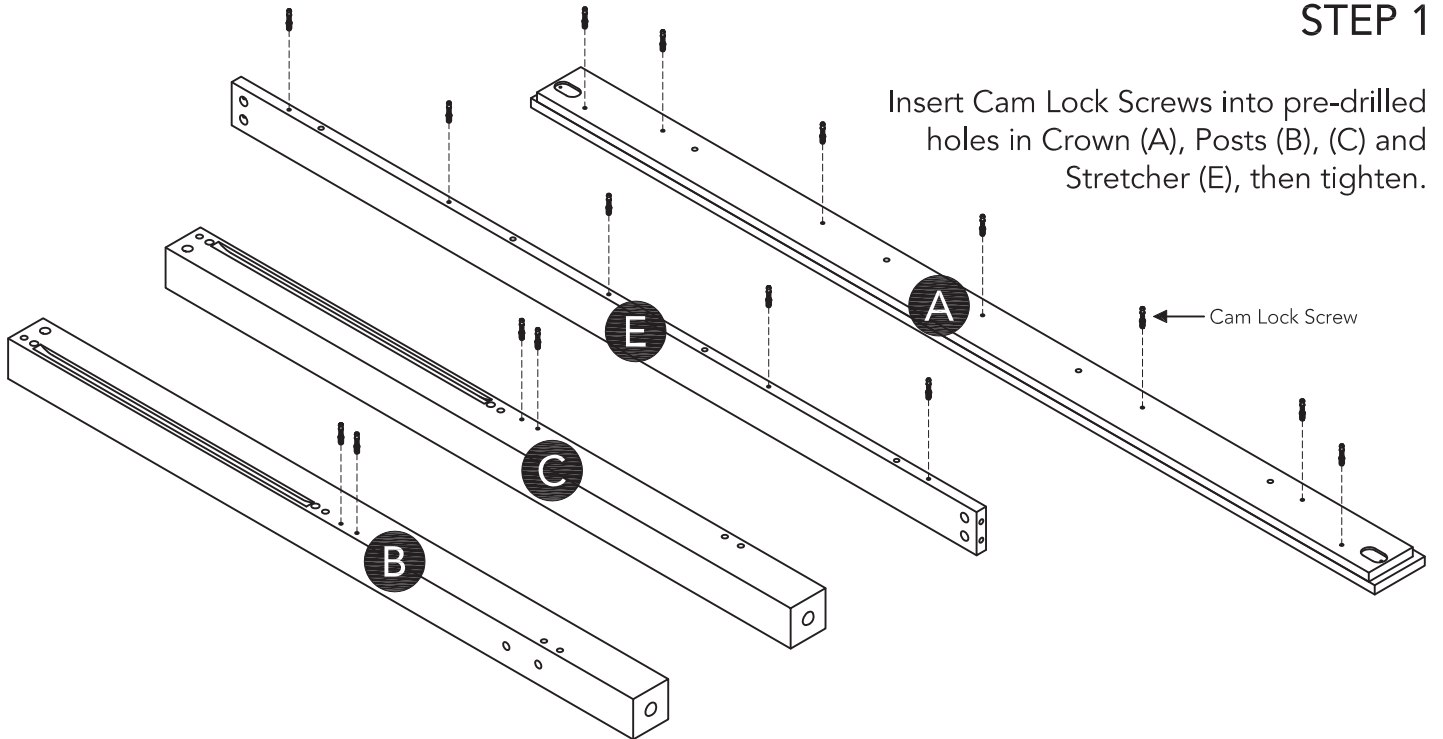

STEP 2

Attach Stretcher (E) to Headboard (D) with Dowels (short) and Cam Locks.
(See Figure 1)

Assembly Instructions 3/6

STEP 3

Insert Bolts into pre-drilled holes in Posts (B) and (C), then tighten.

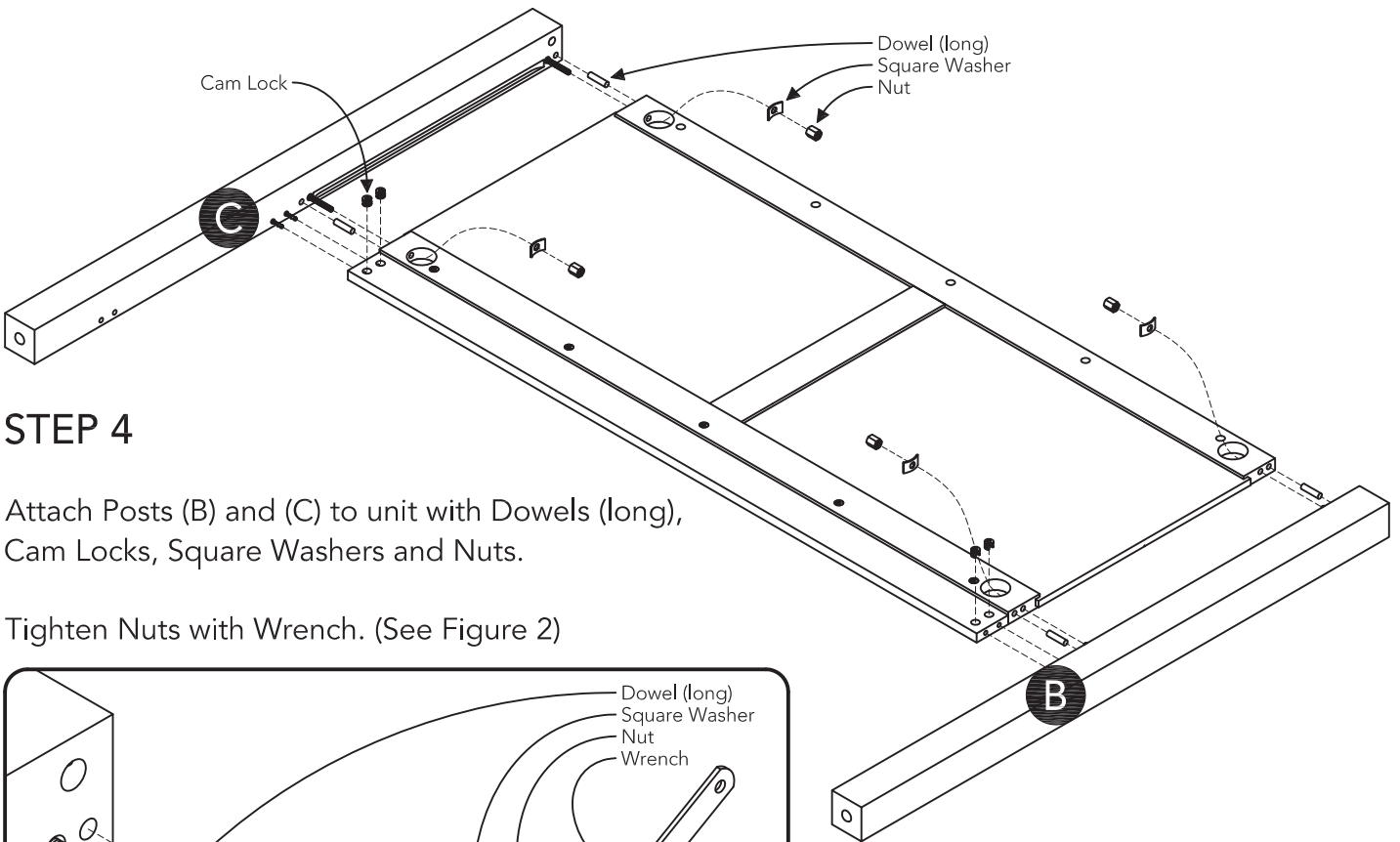
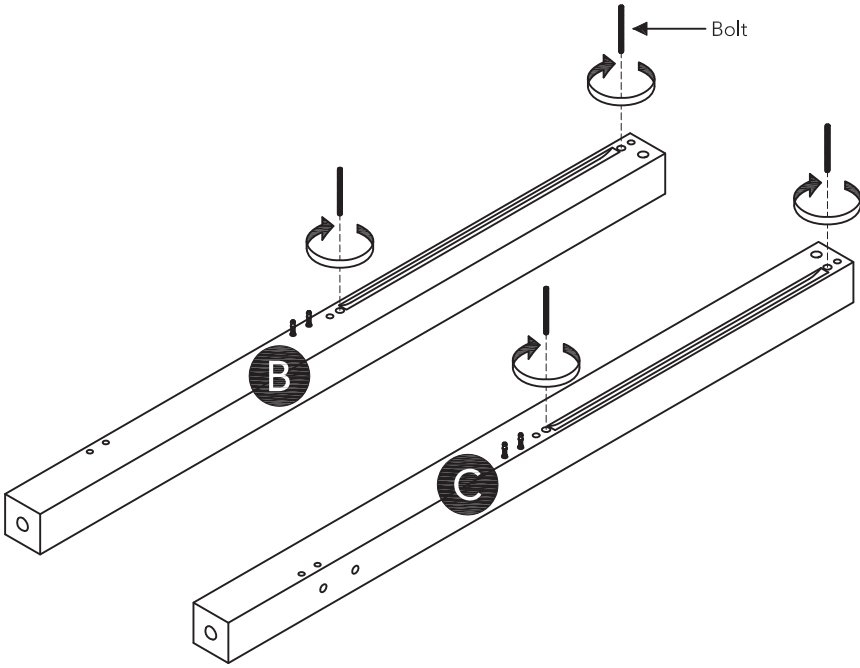

STEP 4

Attach Posts (B) and (C) to unit with Dowels (long), Cam Locks, Square Washers and Nuts.

Tighten Nuts with Wrench. (See Figure 2)

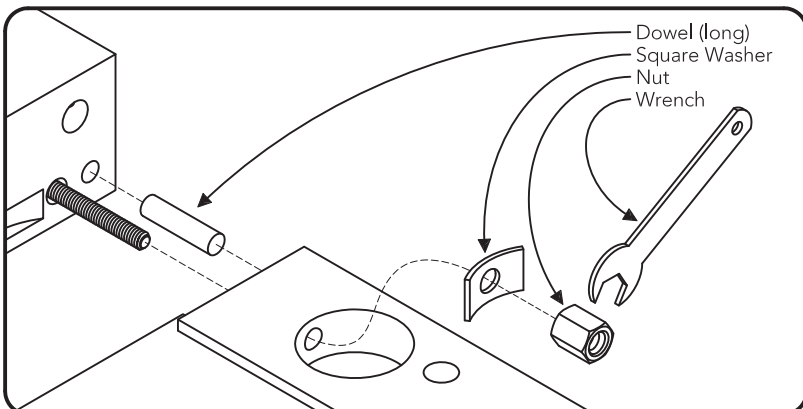

Figure 2

Assembly Instructions 4/6

STEP 5

Attach Corner Plates to unit with Flat Washers, Spring Washers and Head Cap Bolts.

Tighten Head Cap Bolts with Hex Wrench. (See Figure 3)

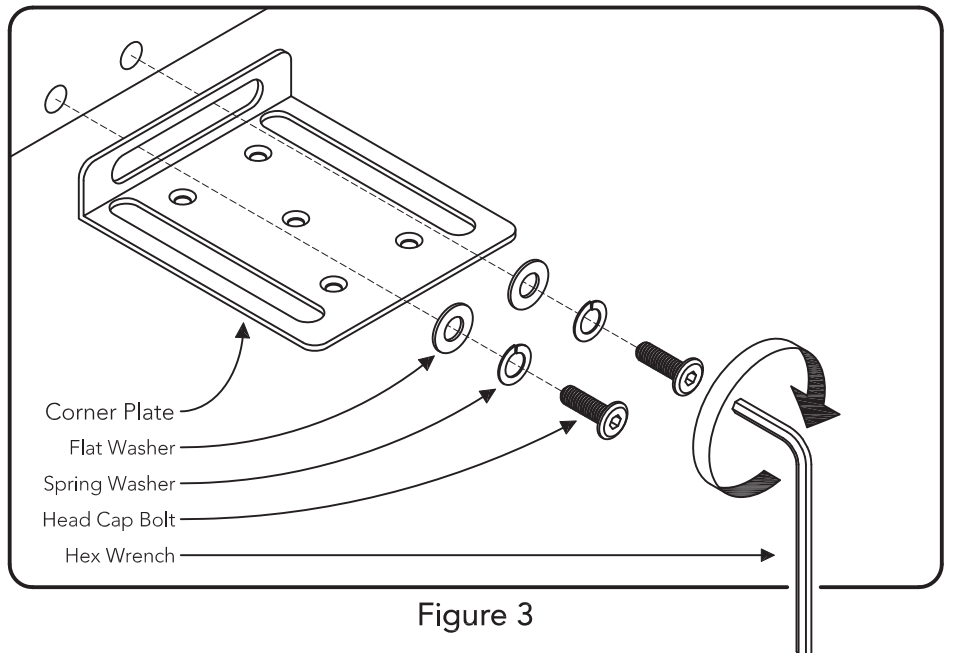
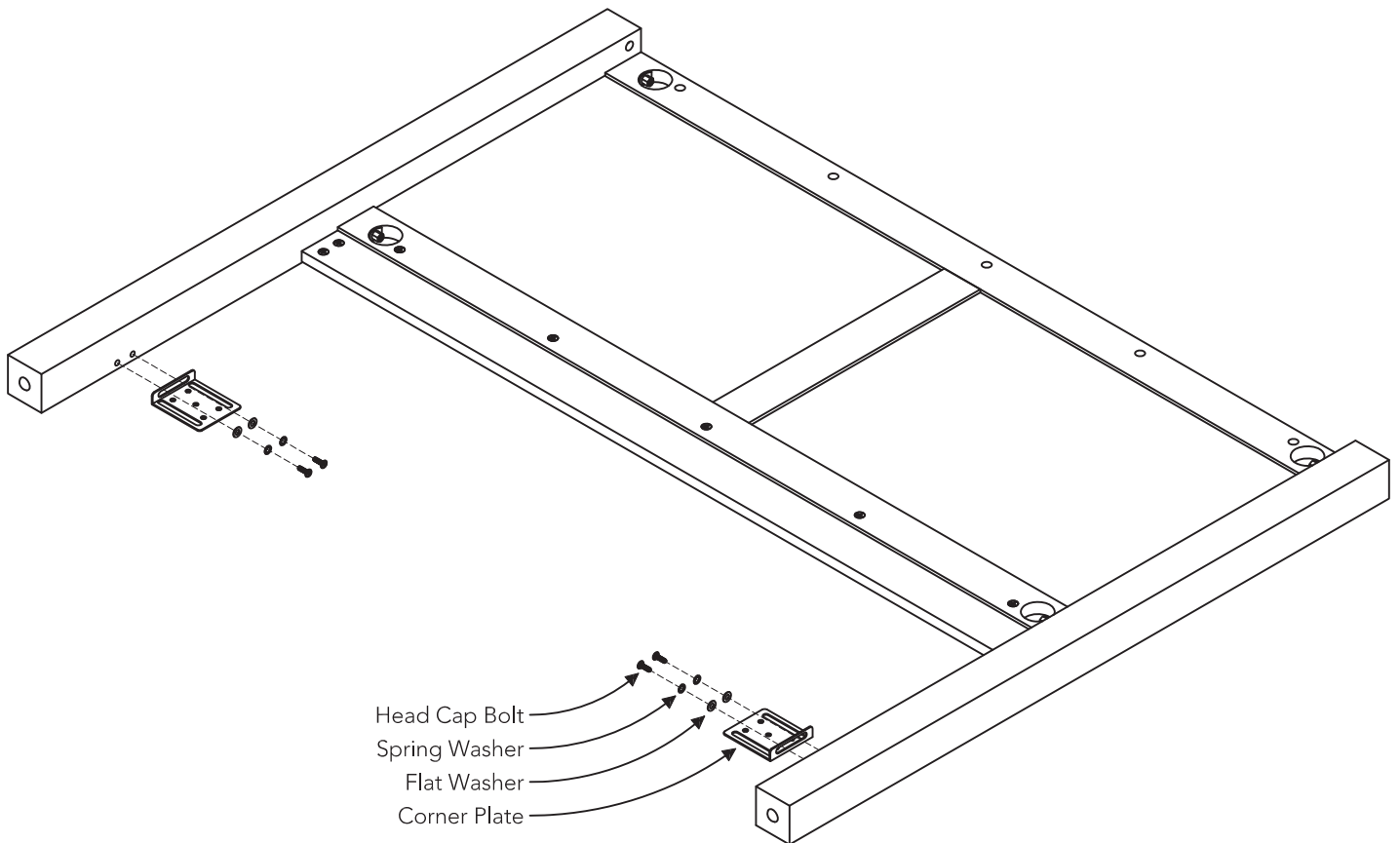

Figure 3

Assembly Instructions 5/6

STEP 6

Attach Plates to unit with 5/8" Flat Head Screws.
(See Figure 4)

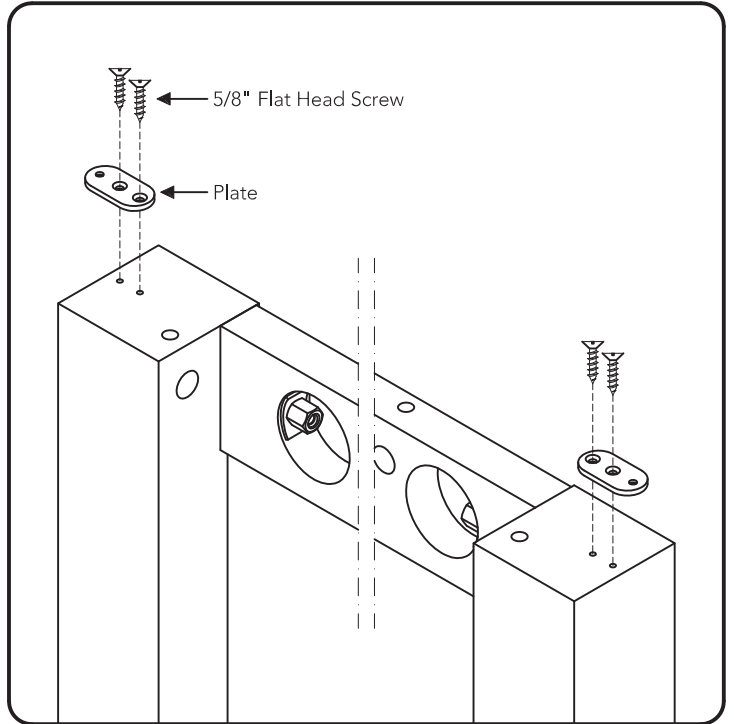
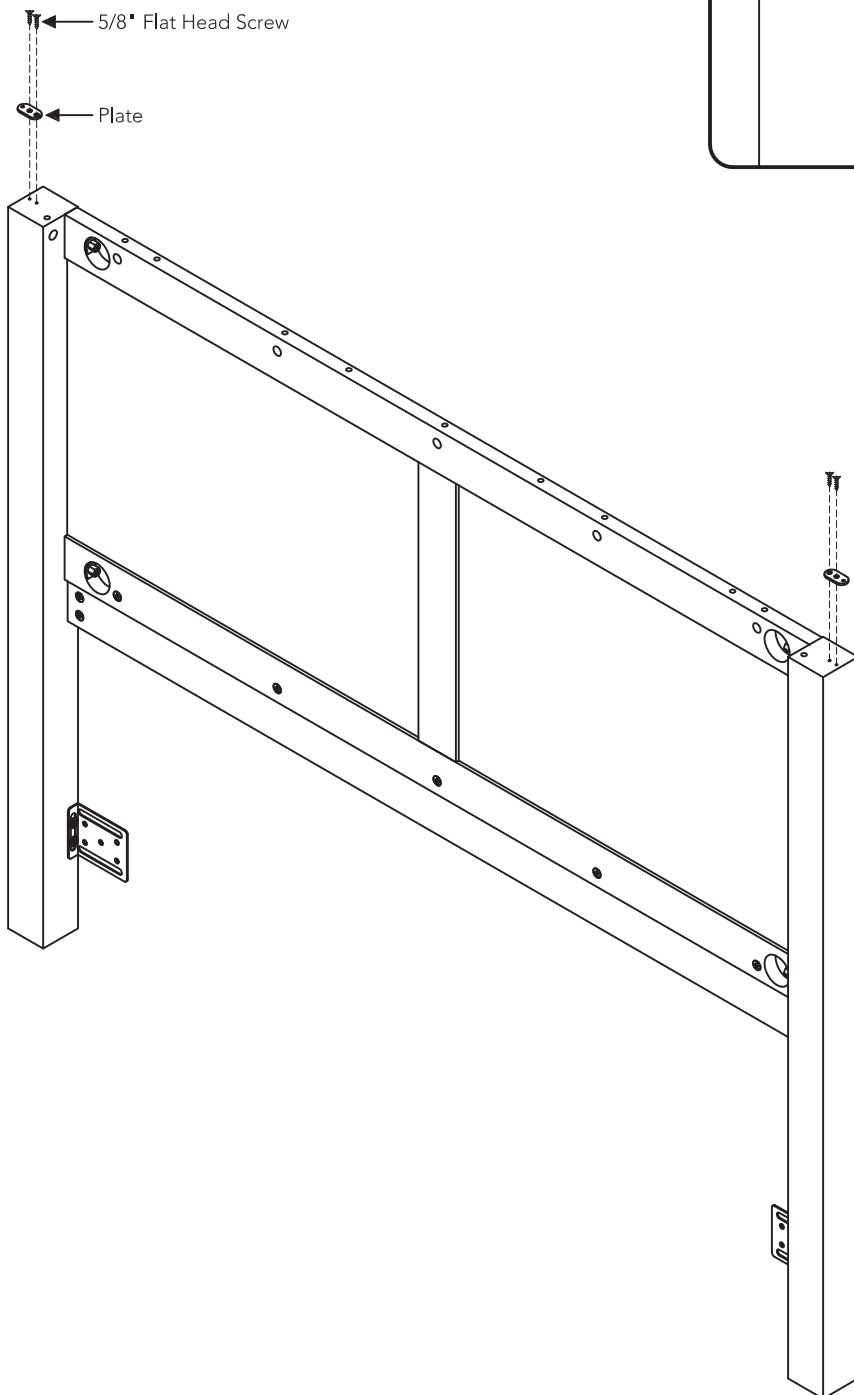

Figure 4



Assembly Instructions 6/6

STEP 7

Attach Crown (A) to unit with Dowels (short), Cam Locks and 5/8" Flat Head Screws.

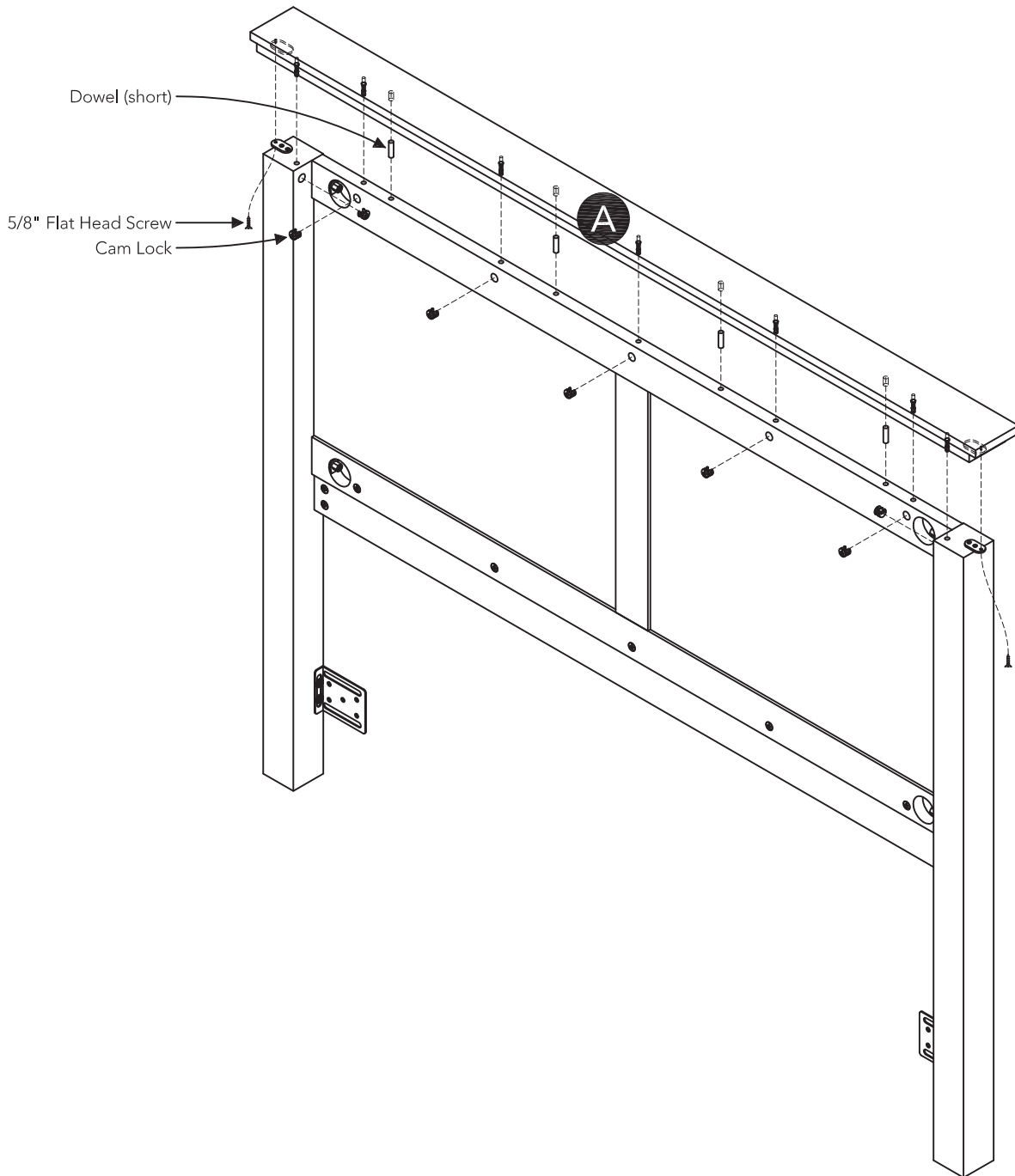

CARE INSTRUCTIONS

NEVER

allow liquids to remain on furniture.
Absorption causes parts to warp
and split and finishes to delaminate.

NEVER

use glass cleaners on
finished furniture. Ammonia
chemically attacks the finish.



Do not use power tools
above 8 volts to assemble.

**PREVENT
CRACKING**



Do not place
in direct sunlight.

**PREVENT
FADING**



Do not write
directly on surface.

**PREVENT
MARKING**



Do not place hot
objects on surface.

**PREVENT
FINISH DAMAGE**



Do not use rubber
based placemats.

**PREVENT
DISCOLORING**



Do not use commercial
waxes and polishes.

**PREVENT
YELLOWING**

CLEAN

with a soft cloth moistened
in lukewarm soap and water.
Buff with a dry clean cloth.



homestyles will provide replacements free of charge for missing or damaged parts within 30 days of purchase. Digital images of the defective parts may be required. If the product was not purchased from an authorized retailer, **homestyles** is under no obligation to provide replacement parts. Parts are not available for fully assembled items nor are parts available for sale. Replacements for missing or damaged parts may be requested via contact info below.

homestyles Customer Service: www.homestylesfurniture.com,
servicedesk@homestylesfurniture.com, 888-680-7460

Queen Footboard

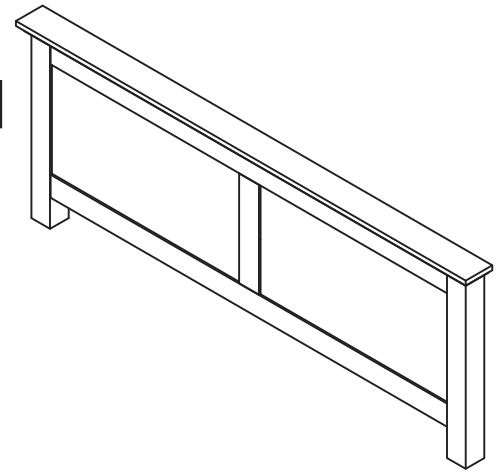

IMPORTANT

Carefully remove all the parts from the carton and place them individually on a soft cloth to prevent scratches or other damage.

Carefully and strictly follow these assembly instructions to ensure a completed product as designed.

Do not use power tools above 8 volts to assemble.

Part List

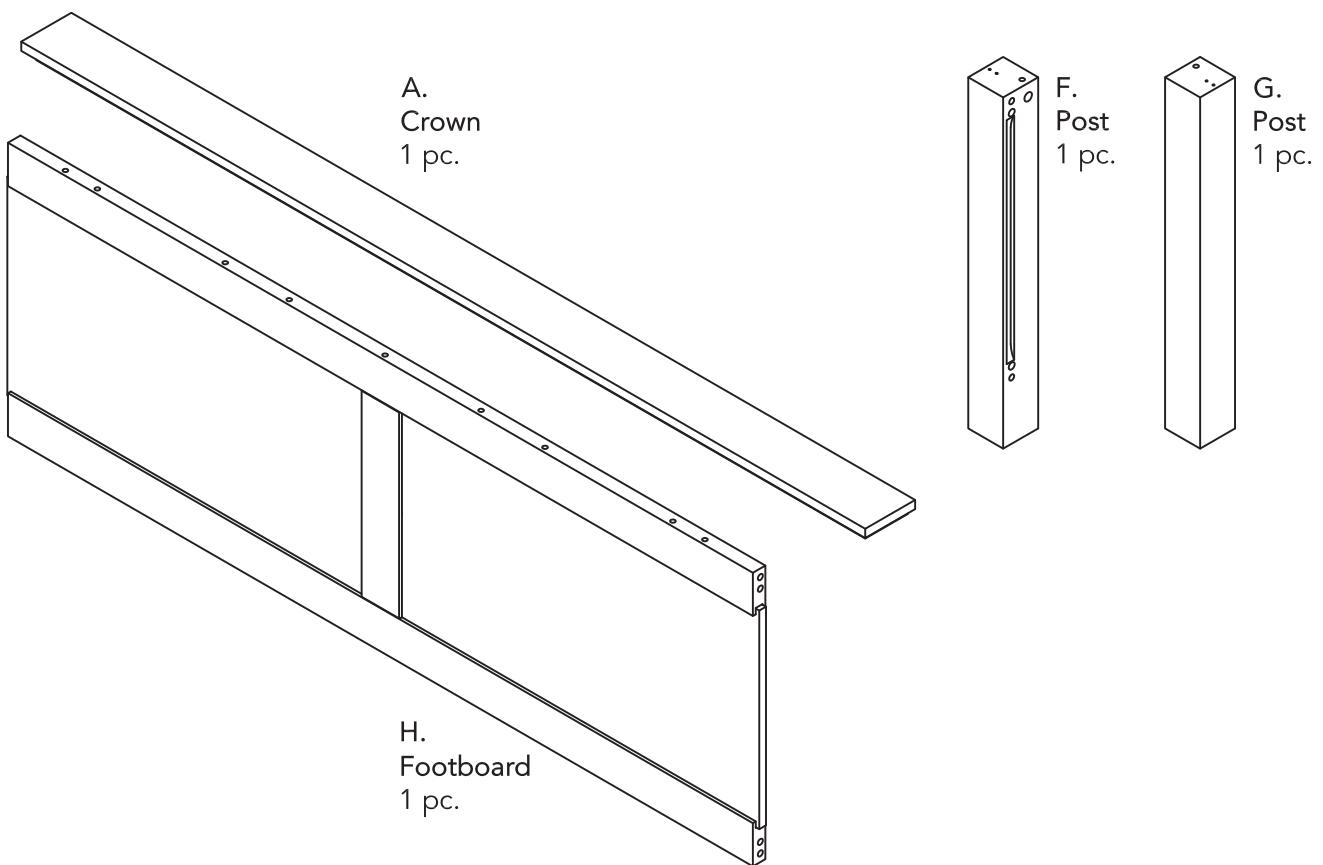

Hardware List



Cam Lock Screw
7 pcs. (+2 extra)



Cam Lock
7 pcs. (+2 extra)



Wrench
1 pc.



5/16" x 3 1/8"
Bolt
4 pcs. (+1 extra)



Square Washer
4 pcs. (+1 extra)



Nut
4 pcs. (+1 extra)



M3x16
5/8" Flat Head Screw
6 pcs. (+1 extra)



Plate
2 pcs.

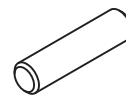

Dowel (long)
4 pcs. (+1 extra)

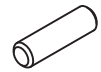

Dowel (short)
4 pcs. (+1 extra)

Tool(s) required for assembly: Phillips screwdriver

homestyles Customer Service: www.homestylesfurniture.com,
servicedesk@homestylesfurniture.com, 888-680-7460

Assembly Instructions 2/4

IMPORTANT

- Use a soft cloth between these parts and the floor.
- Do not use power tools above 8 volts to assemble.
- Do not tighten all the bolts until each part is properly assembled.
- Keep Wrench and Hex Wrench as the Nuts and Head Cap Bolts may need to be tightened in the future.

STEP 1

Insert Bolts into pre-drilled holes in Posts (F) and (G), then tighten.

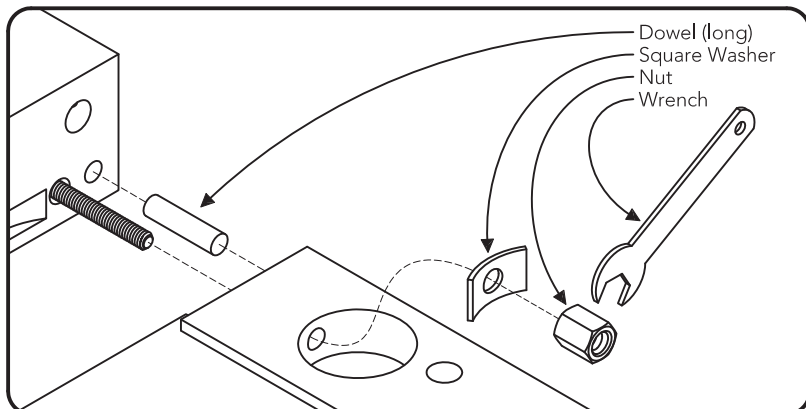
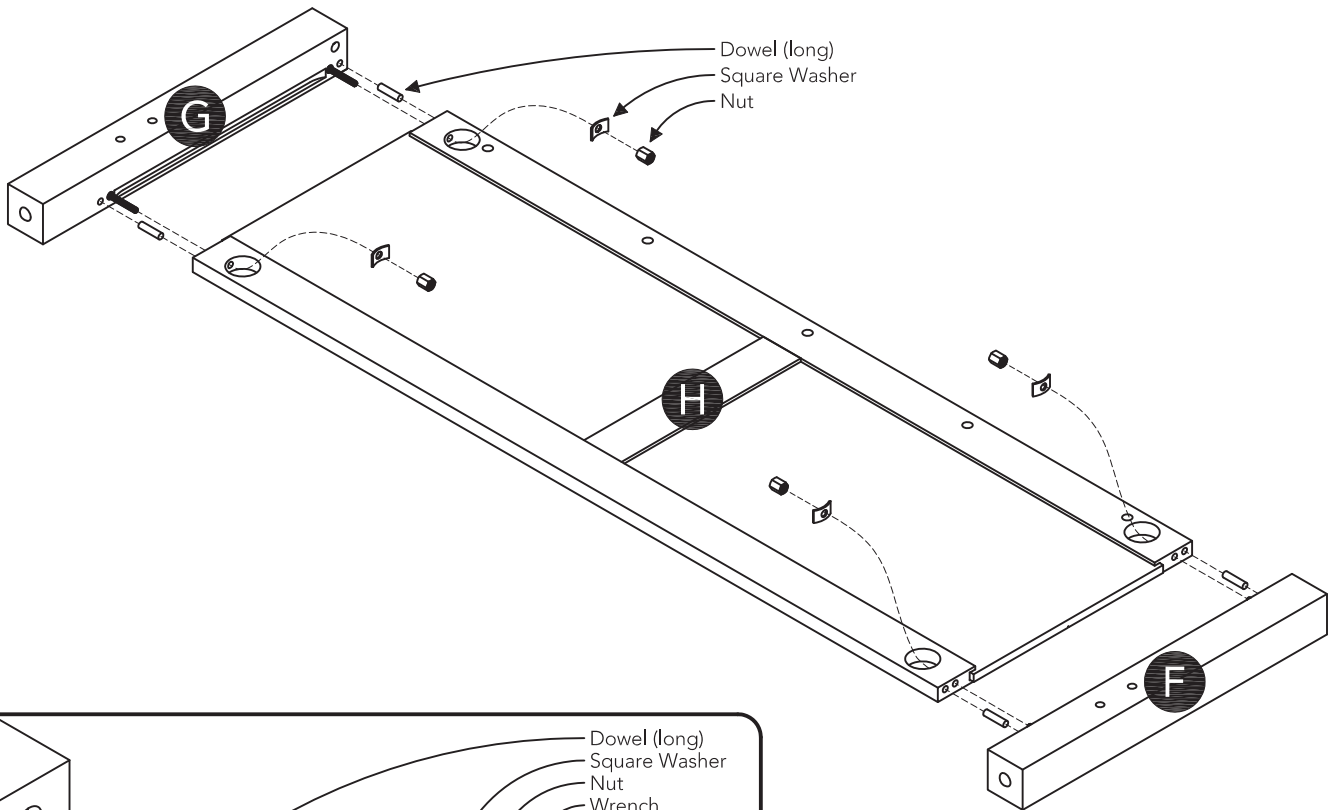
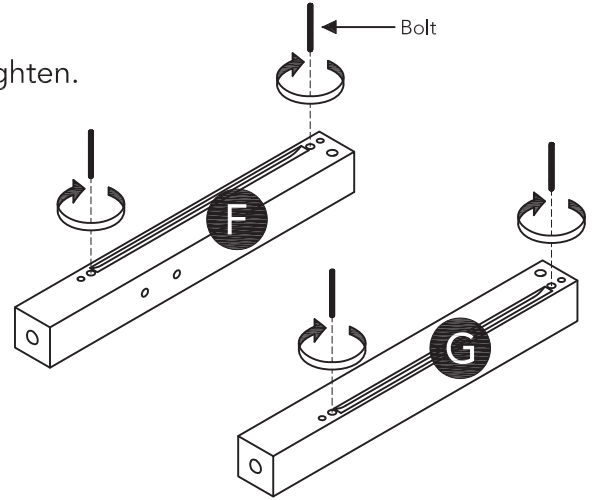

Figure 1

STEP 2

Attach Posts (F) and (G) to Footboard (H) with Dowels (long), Square Washers and Nuts.

Tighten Nuts with Wrench. (See Figure 1)

Assembly Instructions 3/4

STEP 3

Attach Plates to unit with 5/8" Flat Head Screws.
(See Figure 2)

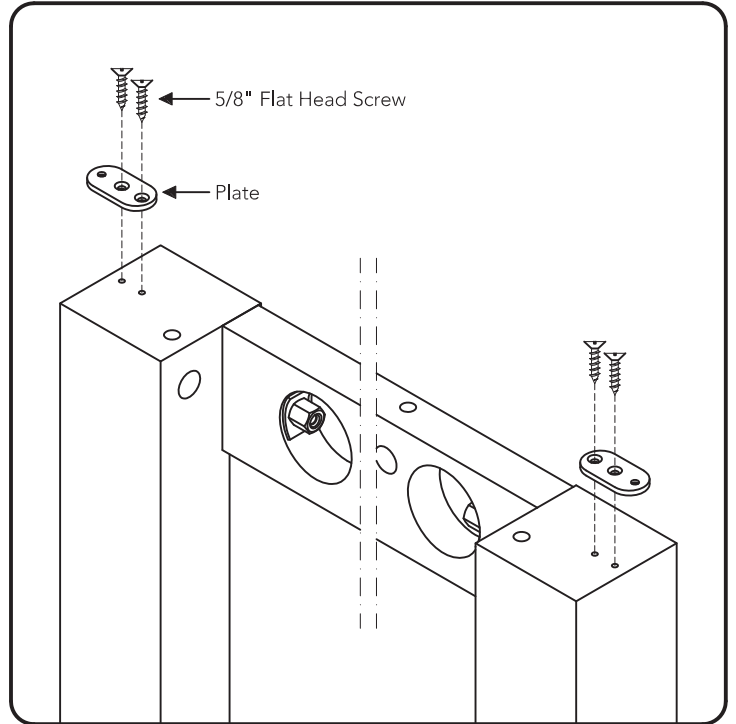
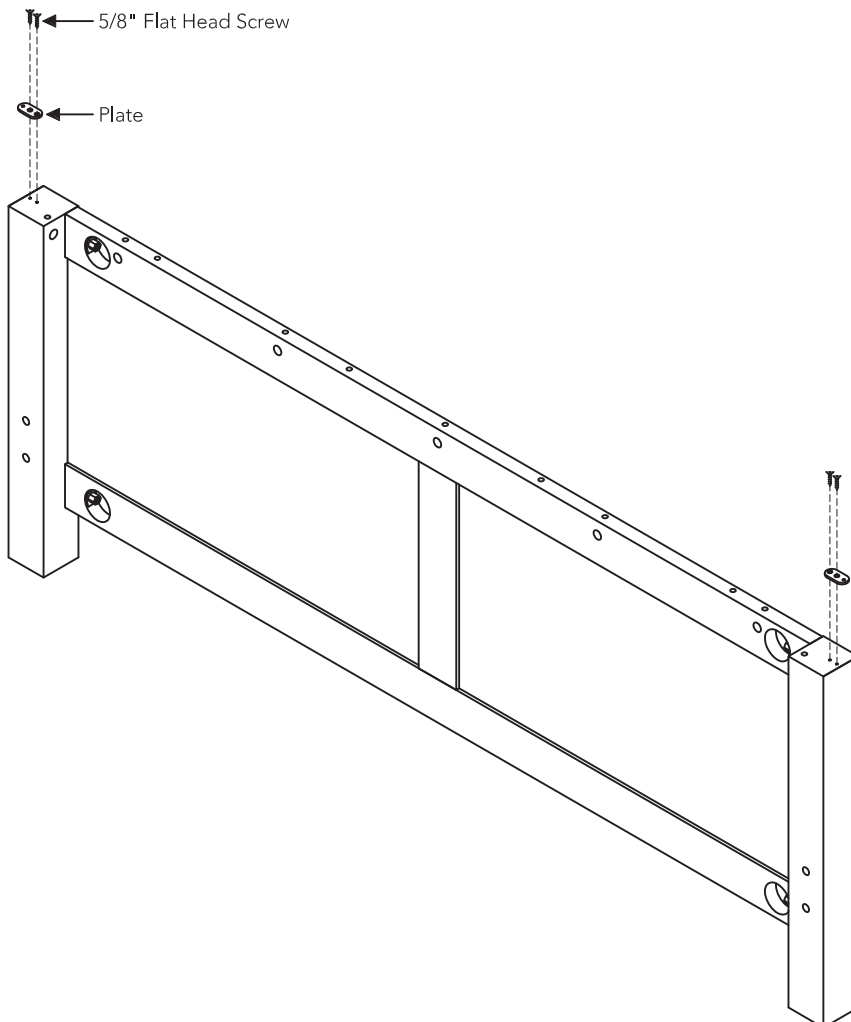

Figure 2



Assembly Instructions 4/4

STEP 4

Insert Cam Lock Screws into pre-drilled holes in Crown (A), then tighten.

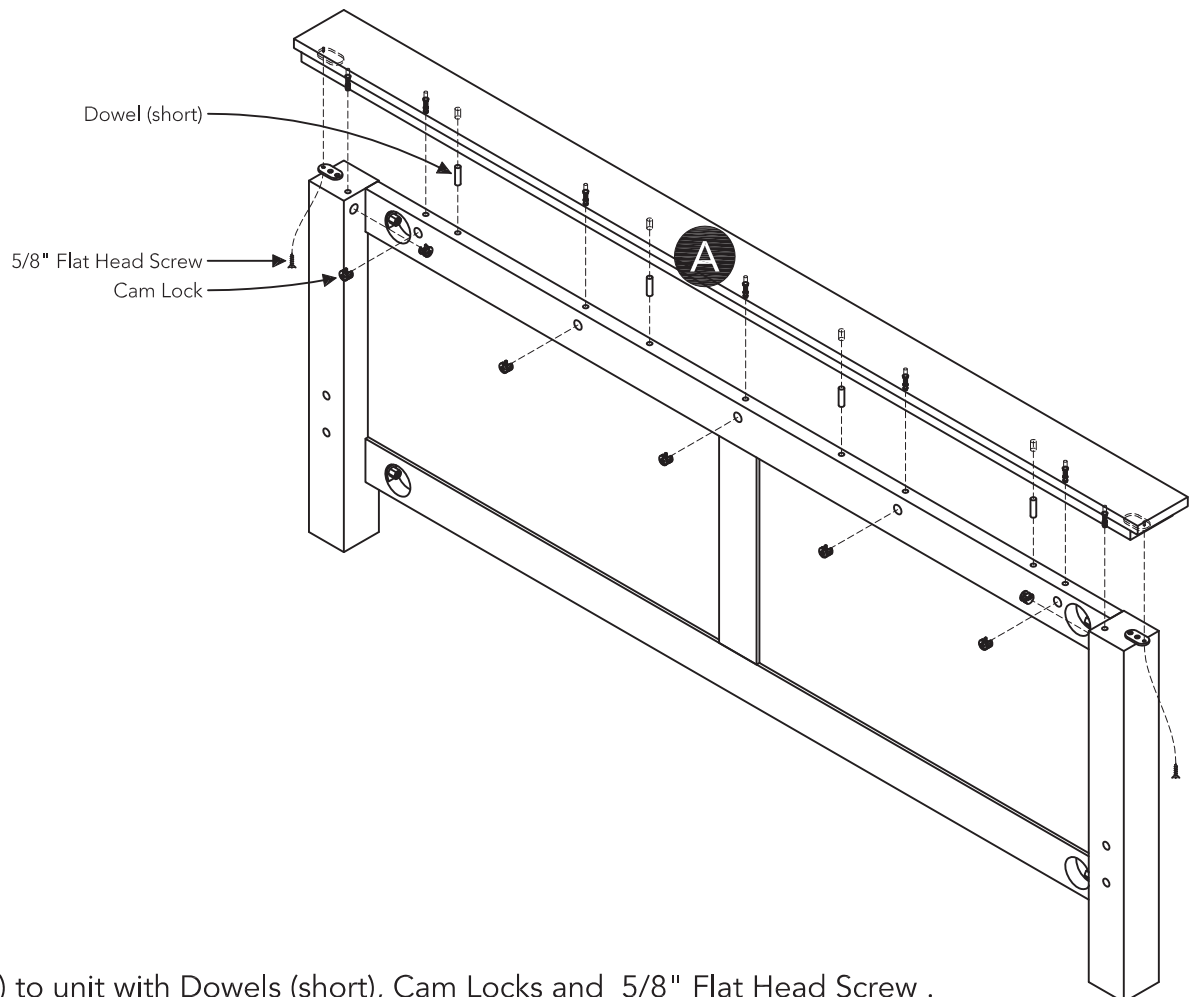
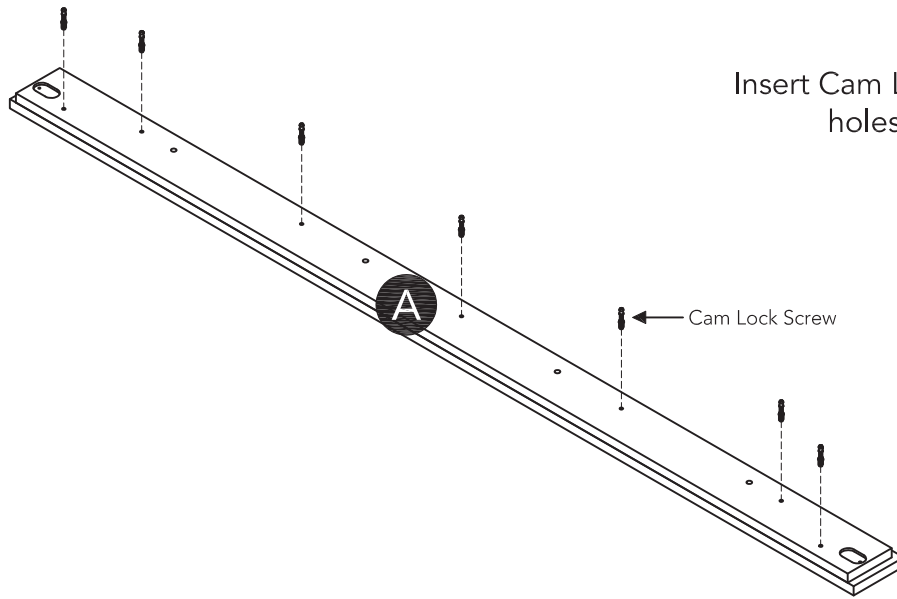

STEP 5

Attach Crown (A) to unit with Dowels (short), Cam Locks and 5/8" Flat Head Screw .

CARE INSTRUCTIONS

NEVER

allow liquids to remain on furniture.
Absorption causes parts to warp
and split and finishes to delaminate.

NEVER

use glass cleaners on
finished furniture. Ammonia
chemically attacks the finish.



Do not use power tools
above 8 volts to assemble.

**PREVENT
CRACKING**



Do not place
in direct sunlight.

**PREVENT
FADING**



Do not write
directly on surface.

**PREVENT
MARKING**



Do not place hot
objects on surface.

**PREVENT
FINISH DAMAGE**



Do not use rubber
based placemats.

**PREVENT
DISCOLORING**



Do not use commercial
waxes and polishes.

**PREVENT
YELLOWING**

CLEAN

with a soft cloth moistened
in lukewarm soap and water.
Buff with a dry clean cloth.



homestyles will provide replacements free of charge for missing or damaged parts within 30 days of purchase. Digital images of the defective parts may be required. If the product was not purchased from an authorized retailer, **homestyles** is under no obligation to provide replacement parts. Parts are not available for fully assembled items nor are parts available for sale. Replacements for missing or damaged parts may be requested via contact info below.

homestyles Customer Service: www.homestylesfurniture.com,
servicedesk@homestylesfurniture.com, 888-680-7460

Queen Bed Rails

IMPORTANT

Carefully remove all the parts from the carton and place them individually on a soft cloth to prevent scratches or other damage.

Carefully and strictly follow these assembly instructions to ensure a completed product as designed.

Do not use power tools above 8 volts to assemble.

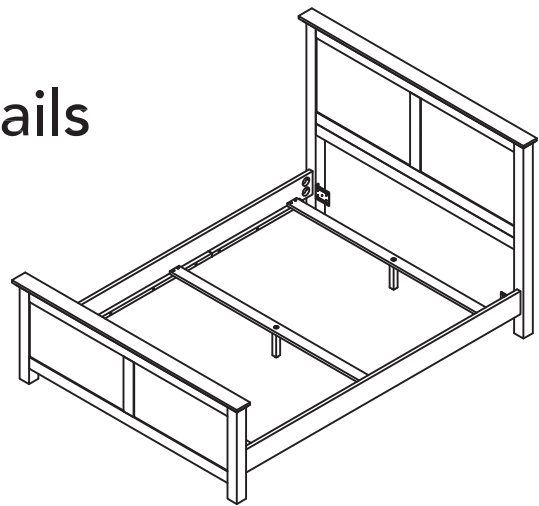

Part List

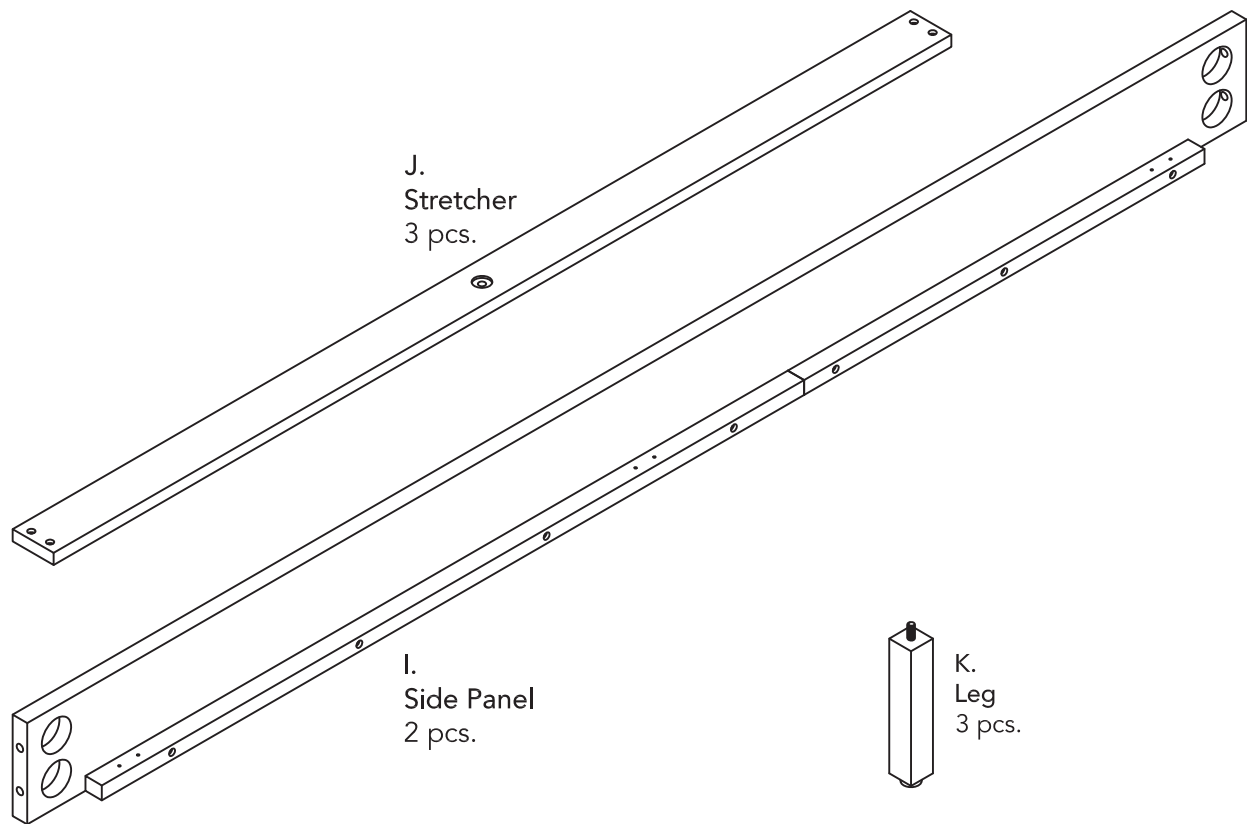

Hardware List



5/16"x3 1/8"
Bolt
8 pcs. (+1 extra)



Square Washer
8 pcs. (+1 extra)



Nut
8 pcs. (+1 extra)



Wrench
1 pc.

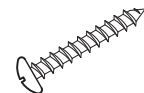

M4x25
Wood Screw
12 pcs. (+1 extra)

Cartons 5911-501 and 502 are also needed for assembly.

Tool(s) required for assembly: Phillips screwdriver, Level

homestyles Customer Service: www.homestylesfurniture.com,
servicedesk@homestylesfurniture.com, 888-680-7460

Assembly Instructions 2/3

IMPORTANT

- Use a soft cloth between these parts and the floor.
- Do not use power tools above 8 volts to assemble.
- Do not tighten all the screws until each part is properly assembled.
- Keep Wrench as the Nuts may need to be tightened in the future.
- Do not slide bed on floor. To move assembled bed requires two people. Remove any bedding, then lift and carry bed.

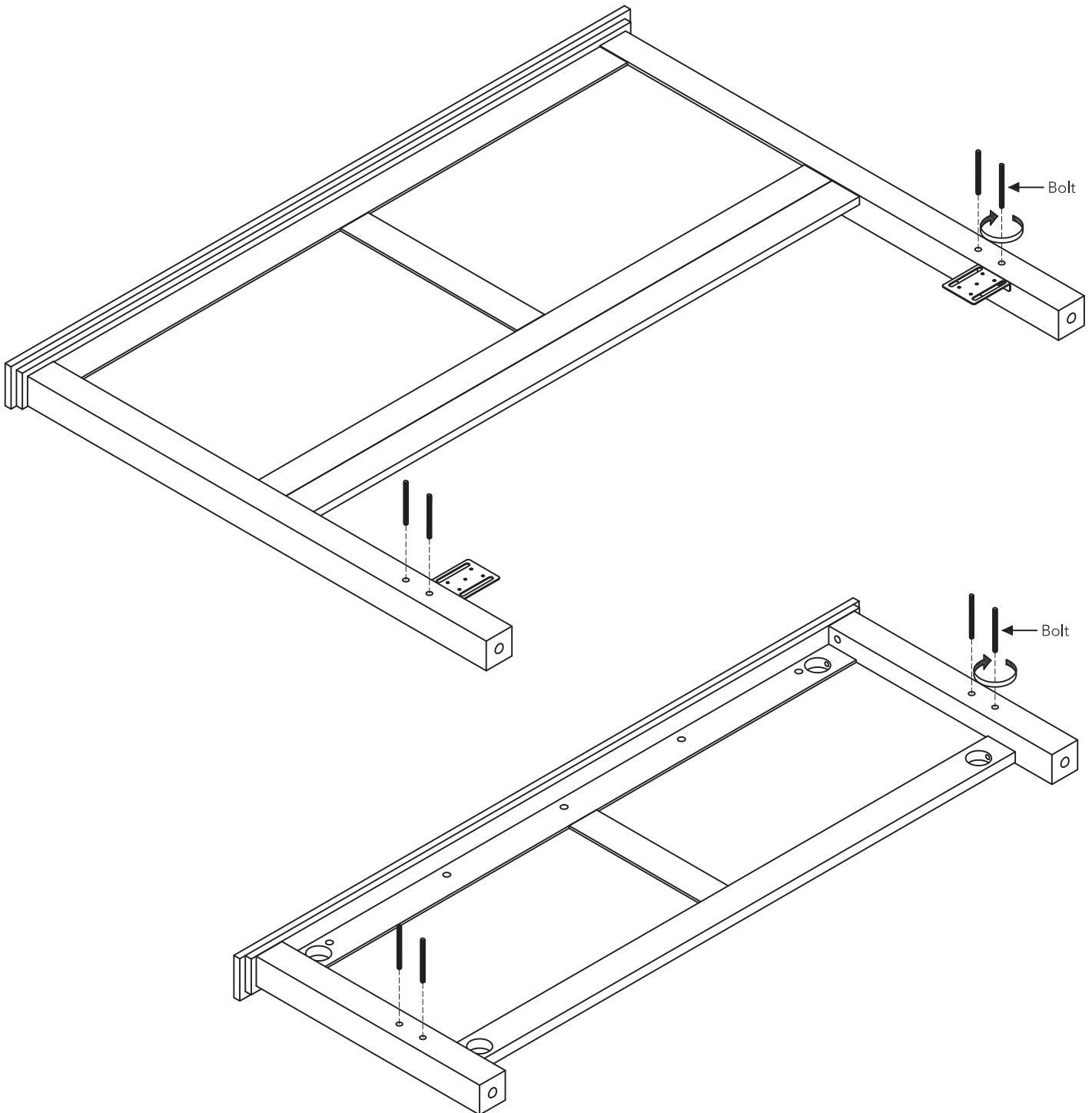

STEP 1

Insert Bolts into pre-drilled holes in Headboard and Footboard, then tighten.

Assembly Instructions 3/3

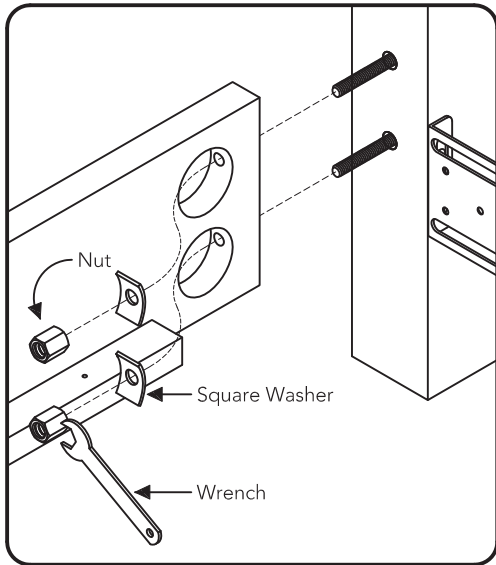
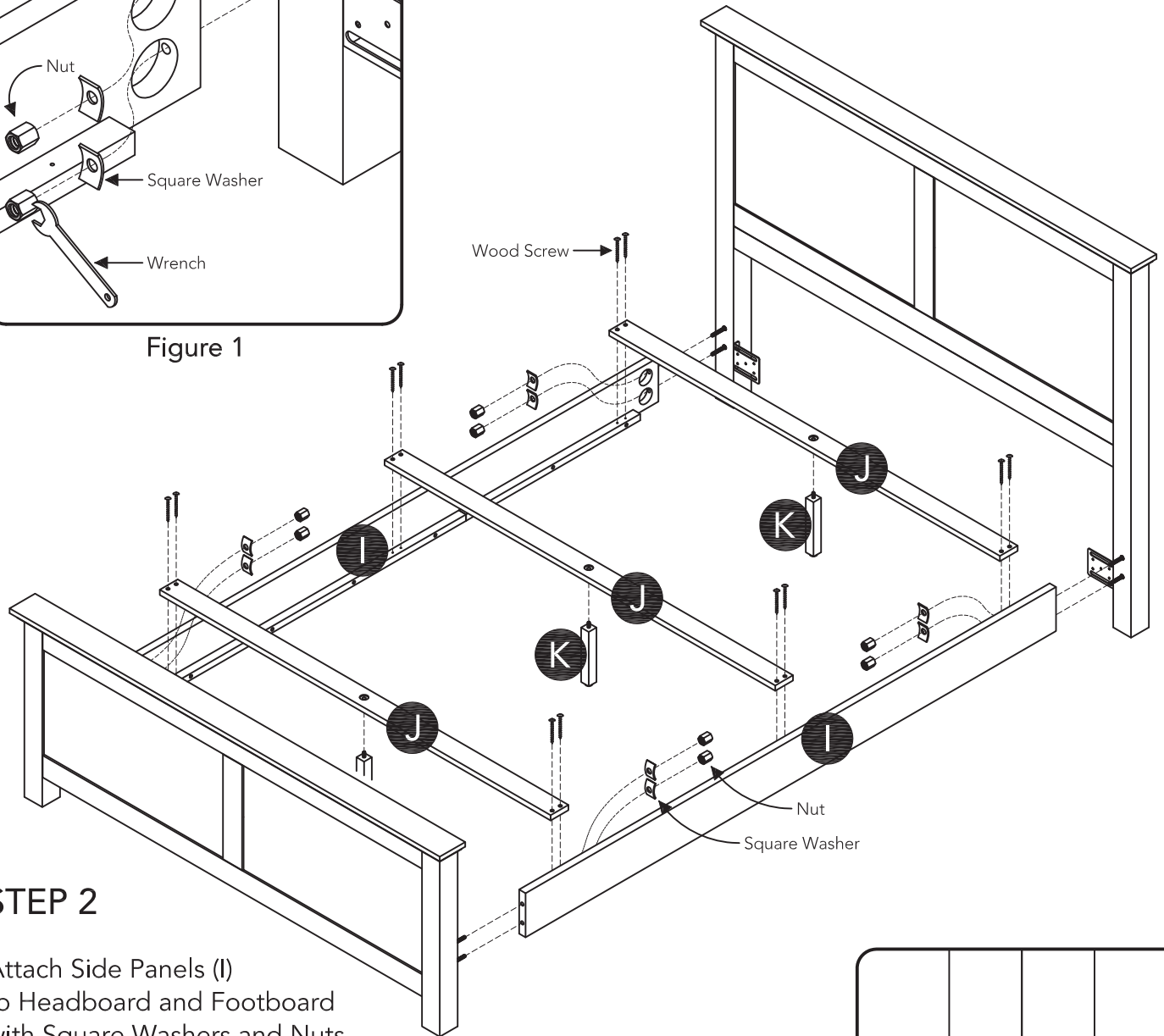

Figure 1



STEP 2

Attach Side Panels (I) to Headboard and Footboard with Square Washers and Nuts.

Tighten all Nuts with Wrench. (See Figure 1)

Insert Legs (K) into pre-drilled holes in Stretches (J), then tighten.

Attach Stretches (J) to unit with Wood Screws into pre-drilled holes.

Level unit by adjusting the adjustable levelers on bottom of legs. (See Figure 2)

Note: Unit must be level to work properly.

Note: Do not slide bed on floor. To move assembled bed requires two people. Remove any bedding, then lift and carry bed.

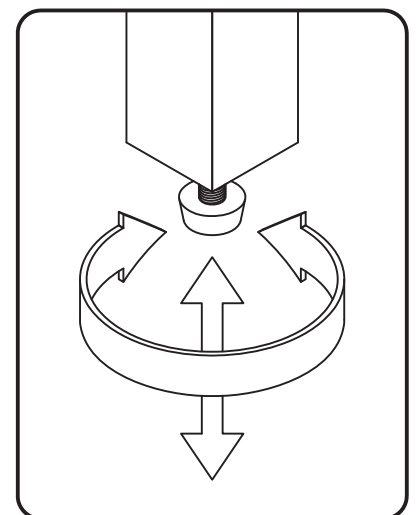

Figure 2

CARE INSTRUCTIONS

NEVER

allow liquids to remain on furniture.
Absorption causes parts to warp
and split and finishes to delaminate.

NEVER

use glass cleaners on
finished furniture. Ammonia
chemically attacks the finish.



Do not use power tools
above 8 volts to assemble.

**PREVENT
CRACKING**



Do not place
in direct sunlight.

**PREVENT
FADING**



Do not write
directly on surface.

**PREVENT
MARKING**



Do not place hot
objects on surface.

**PREVENT
FINISH DAMAGE**



Do not use rubber
based placemats.

**PREVENT
DISCOLORING**



Do not use commercial
waxes and polishes.

**PREVENT
YELLOWING**

CLEAN

with a soft cloth moistened
in lukewarm soap and water.
Buff with a dry clean cloth.



homestyles will provide replacements free of charge for missing or damaged parts within 30 days of purchase. Digital images of the defective parts may be required. If the product was not purchased from an authorized retailer, **homestyles** is under no obligation to provide replacement parts. Parts are not available for fully assembled items nor are parts available for sale. Replacements for missing or damaged parts may be requested via contact info below.

homestyles Customer Service: www.homestylesfurniture.com,
servicedesk@homestylesfurniture.com, 888-680-7460



IMPORTANT

Carefully remove all the parts from the carton and place them individually on a soft cloth to prevent scratches or other damage.

Carefully and strictly follow these assembly instructions to ensure a completed product as designed.

Do not use power tools above 8 volts to assemble.

Part List

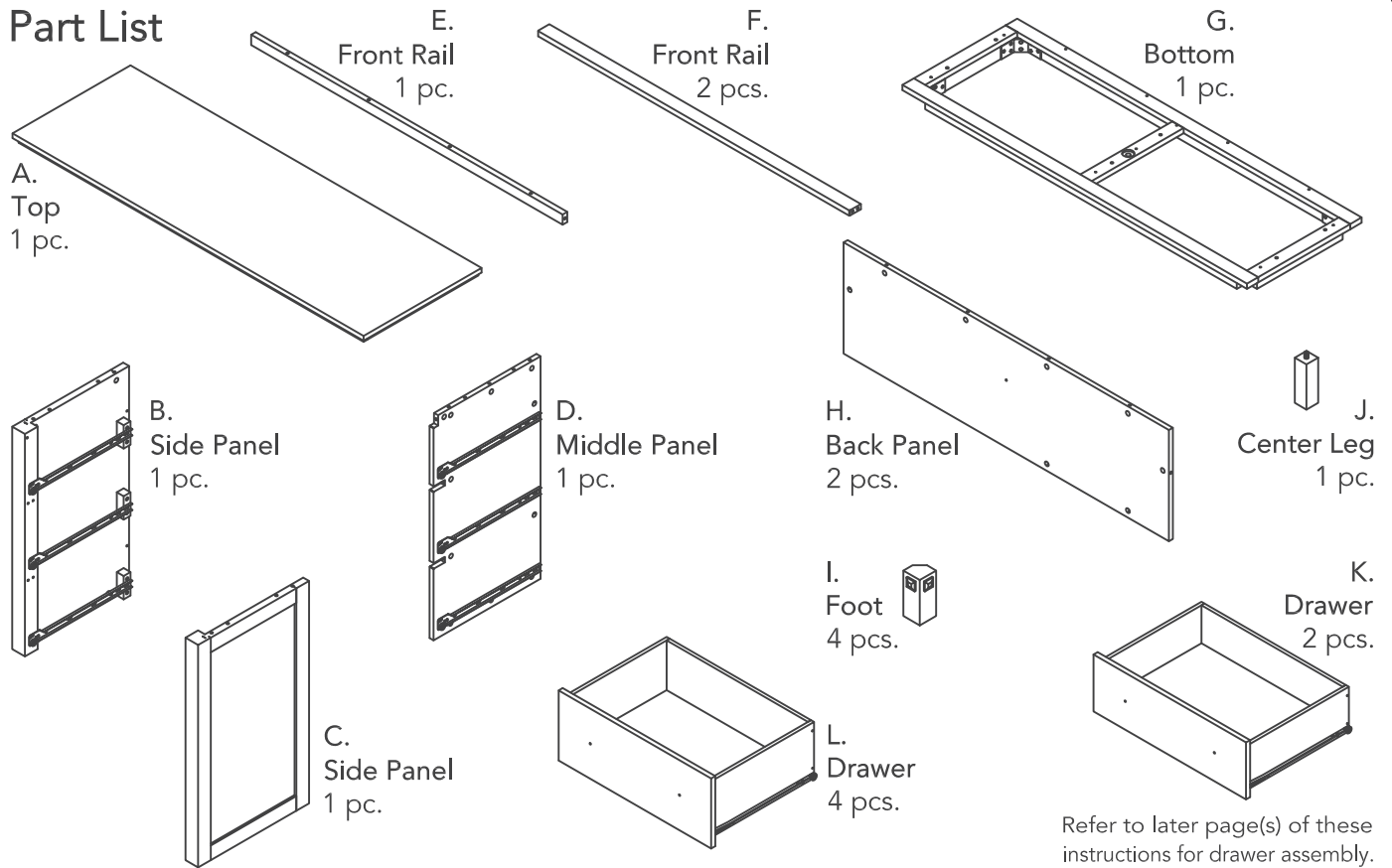

Hardware List

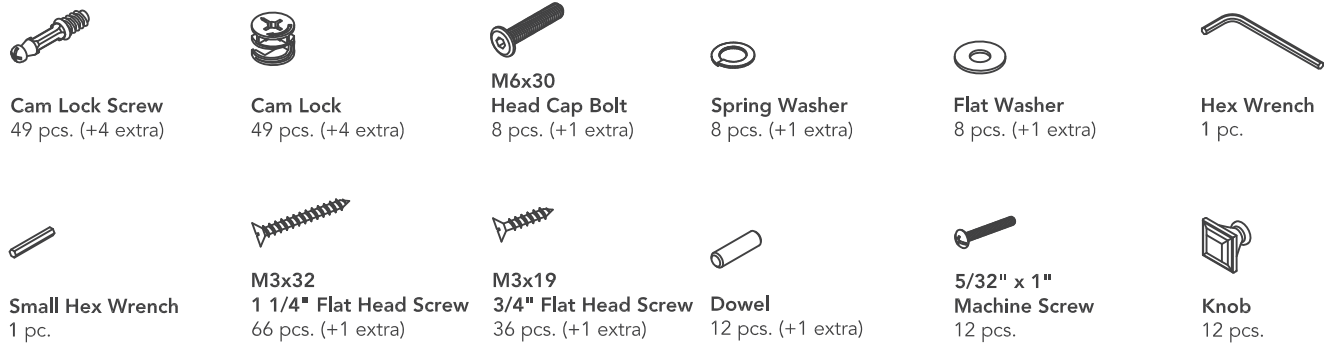

Tool(s) required for assembly: Phillips screwdriver, Level, Pencil, Drill (8 volts or less), 3/8" Drill Bit

homestyles Customer Service: www.homestylesfurniture.com,
servicedesk@homestylesfurniture.com, 888-680-7460

Assembly Instructions 2/11

IMPORTANT

- Use a soft cloth between these parts and the floor.
- Do not use power tools above 8 volts to assemble.
- Do not tighten all the screws until each part is properly assembled.
- The unit must be level to work properly. Use the included adjustable levelers to level.

STEP 1

Insert Cam Lock Screws into pre-drilled holes in Top (A), Side Panels (B), (C), Front Rails (E), (F), Bottom (G) and Back Panels (H), then tighten.

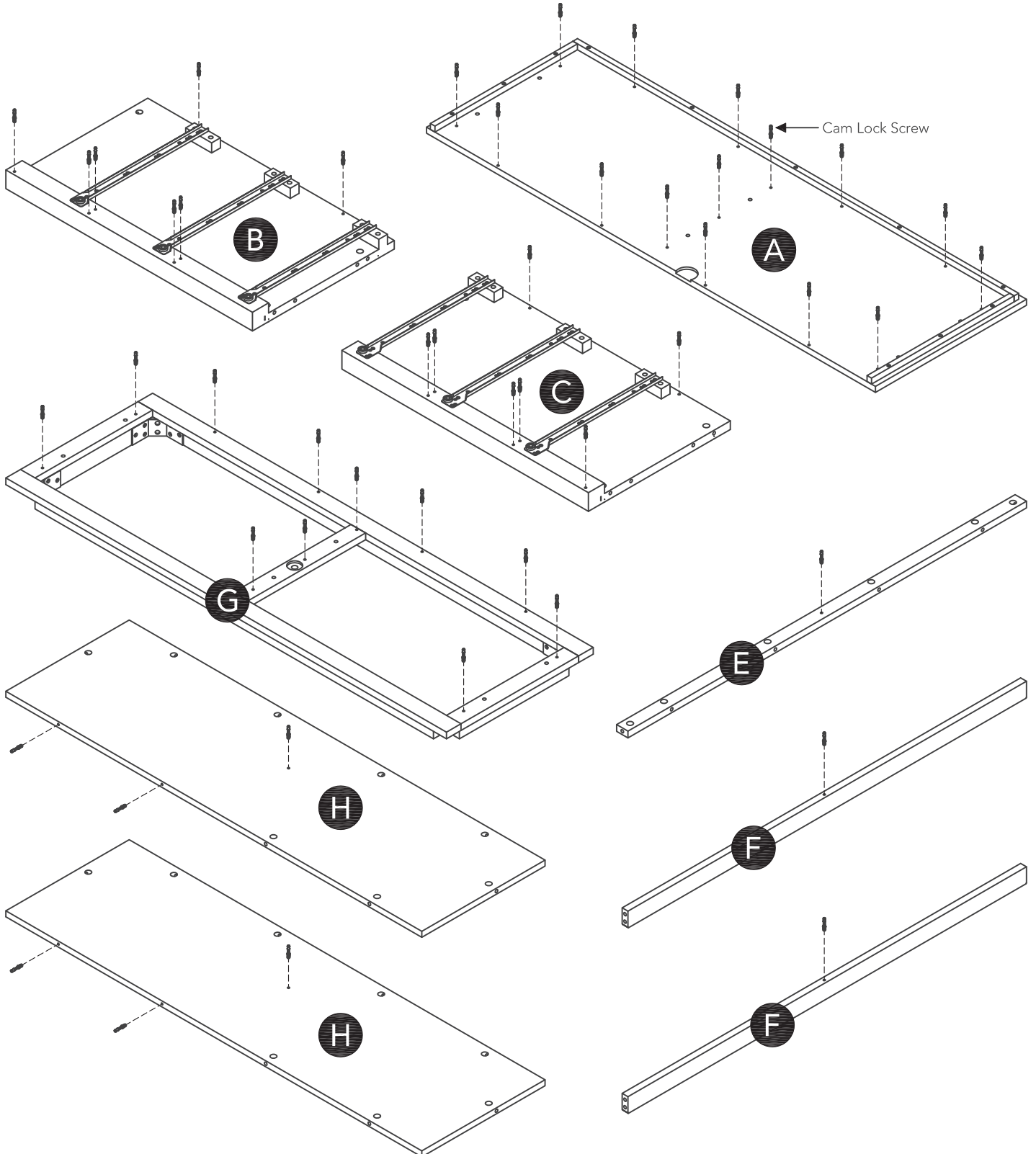

Assembly Instructions 3/11

STEP 2

Assemble Back Panels (H) with Cam Locks. (See Figure 1)

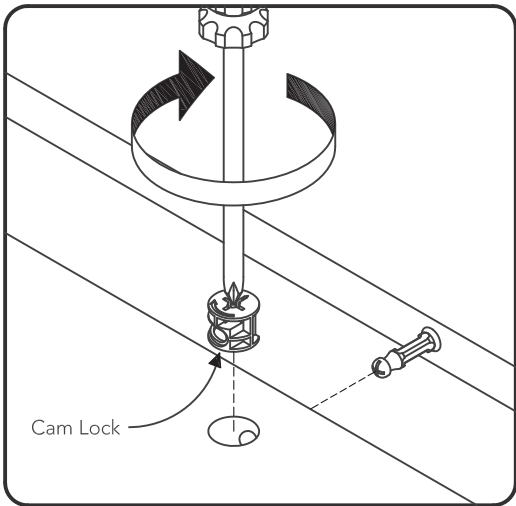
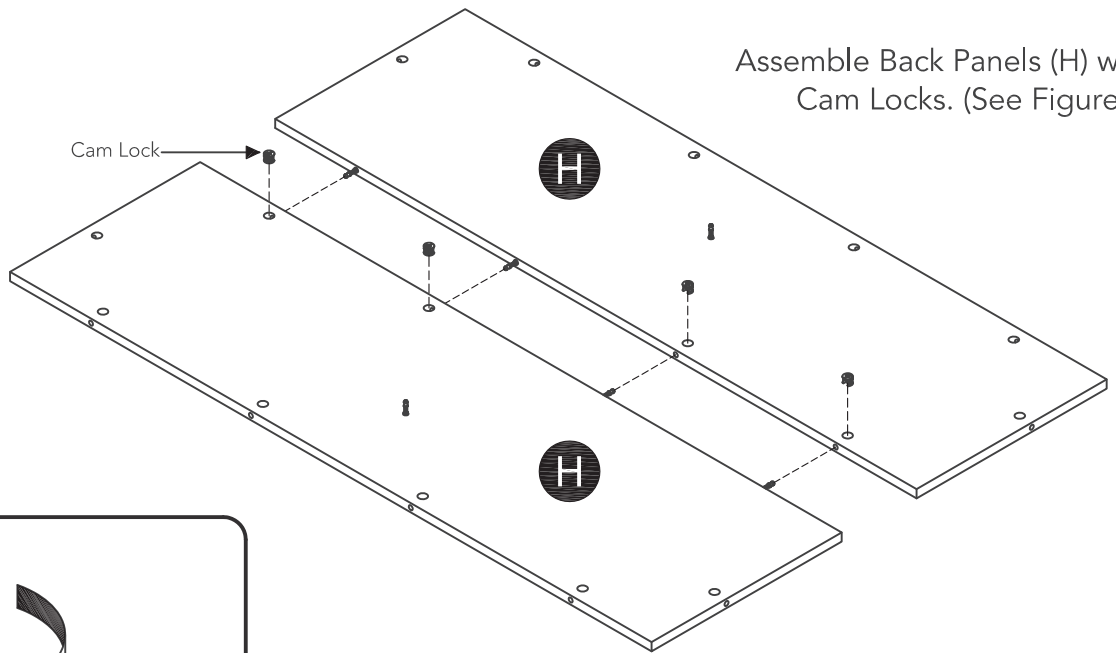
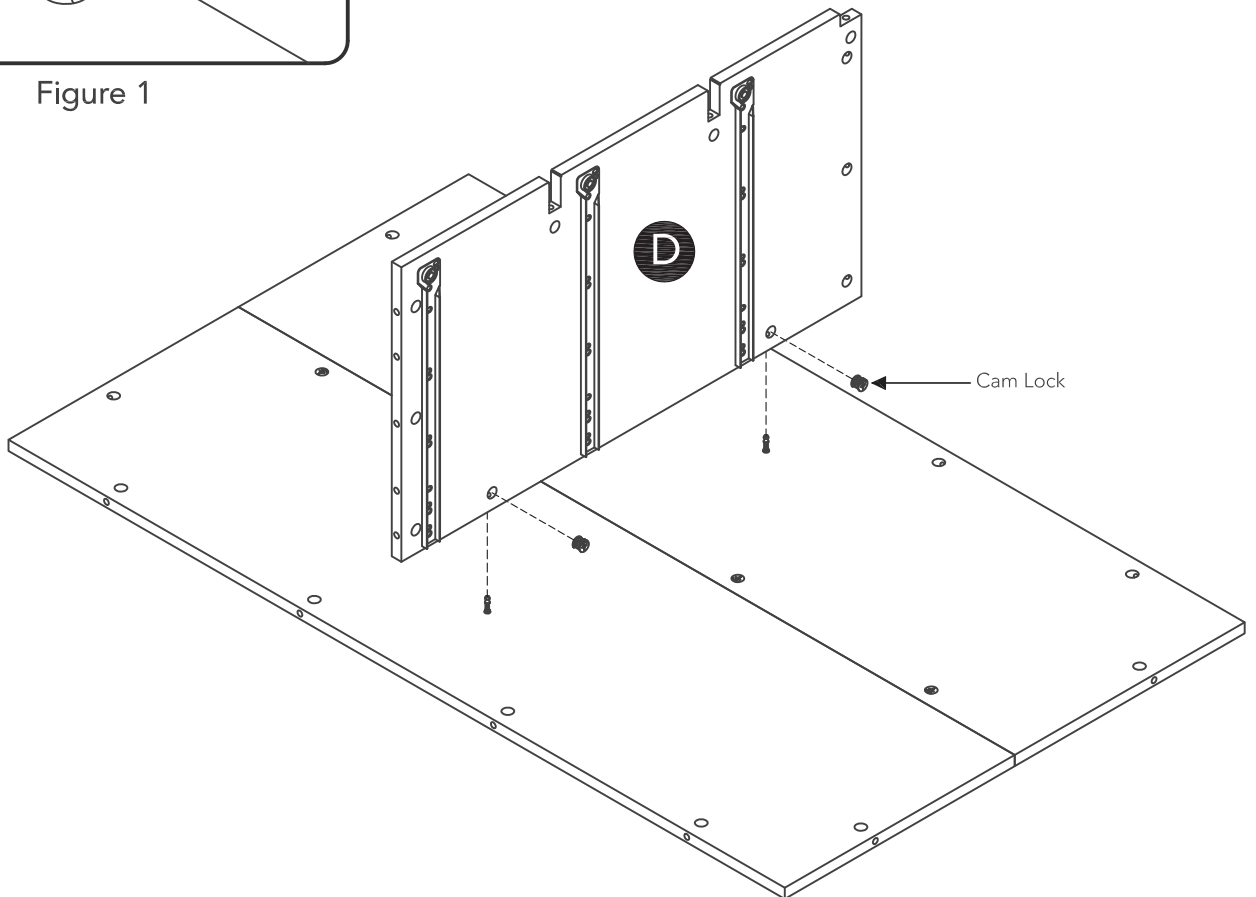

Figure 1



STEP 3

Attach Middle Panel (D) to unit with Cam Locks.

STEP 4

Attach Front Rails (E) and (F) to unit with Cam Locks.

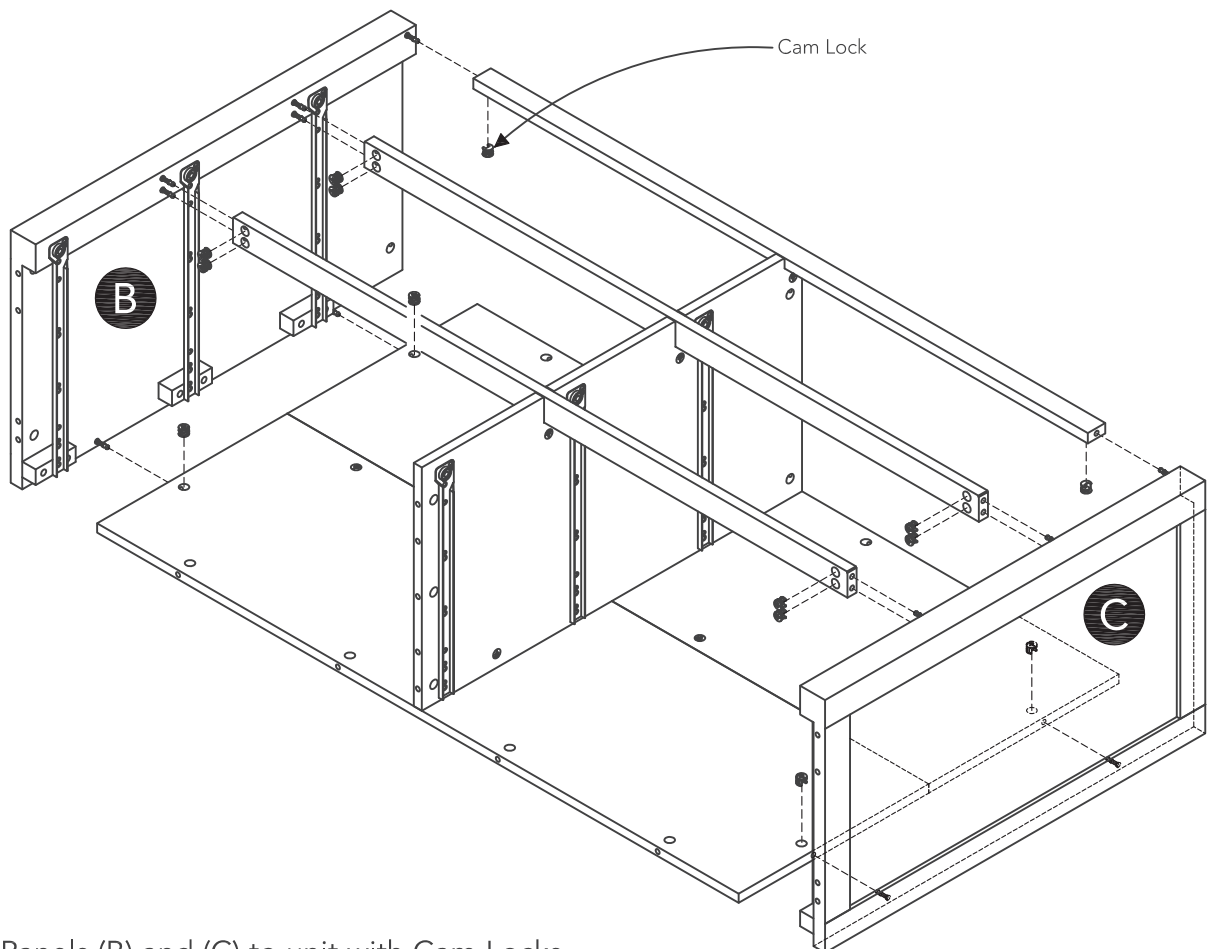
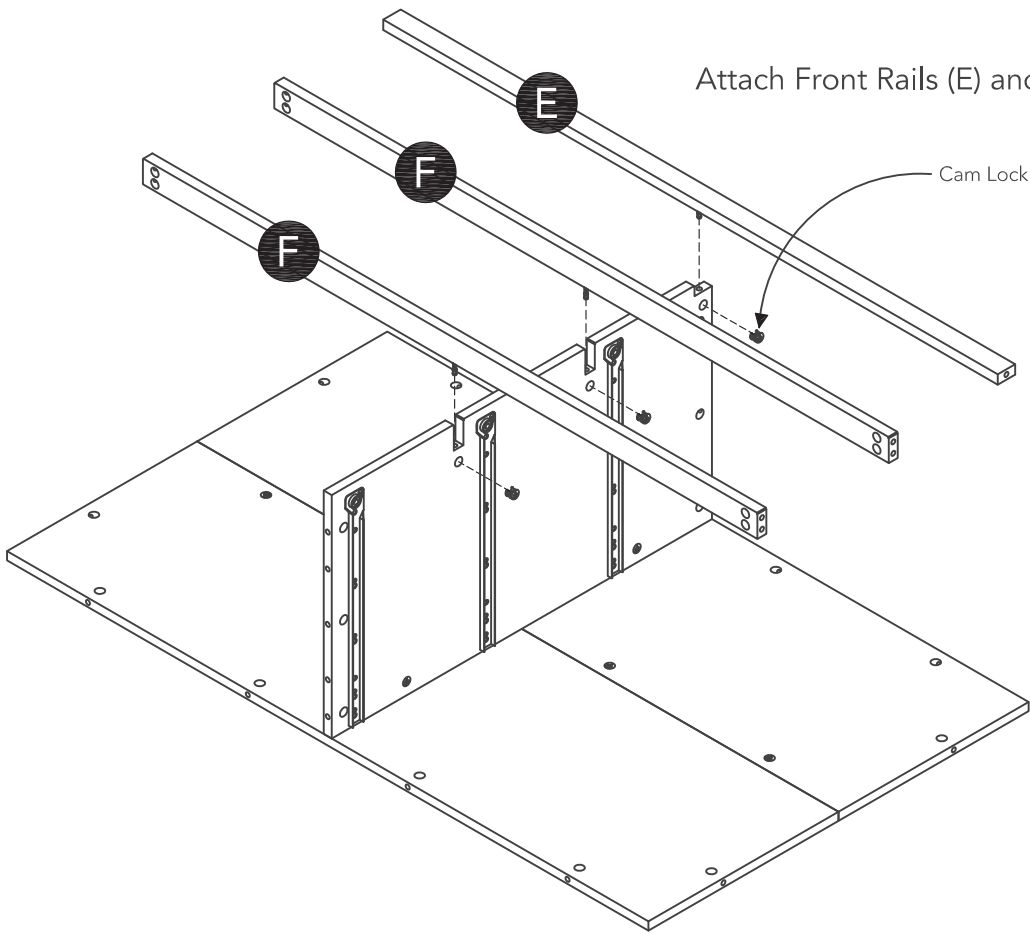

STEP 5

Attach Side Panels (B) and (C) to unit with Cam Locks.

STEP 6

Attach Bottom (G) to unit with Cam Locks and Dowels.

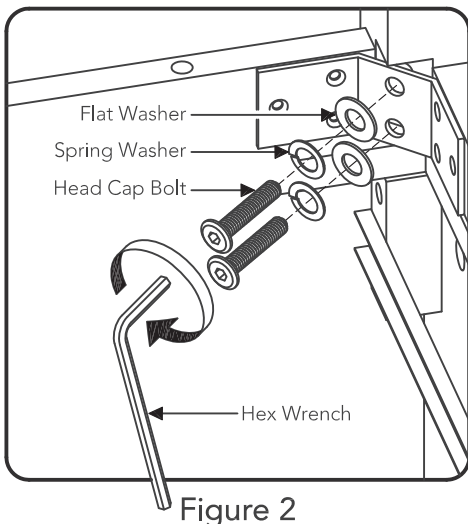
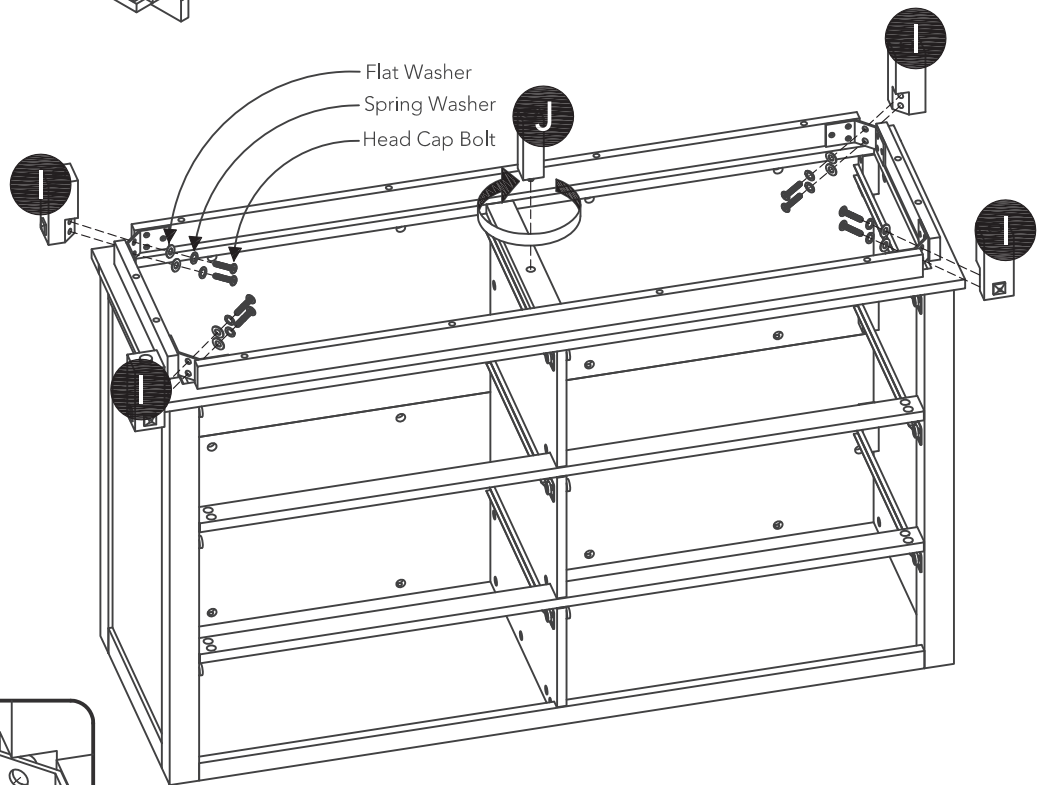
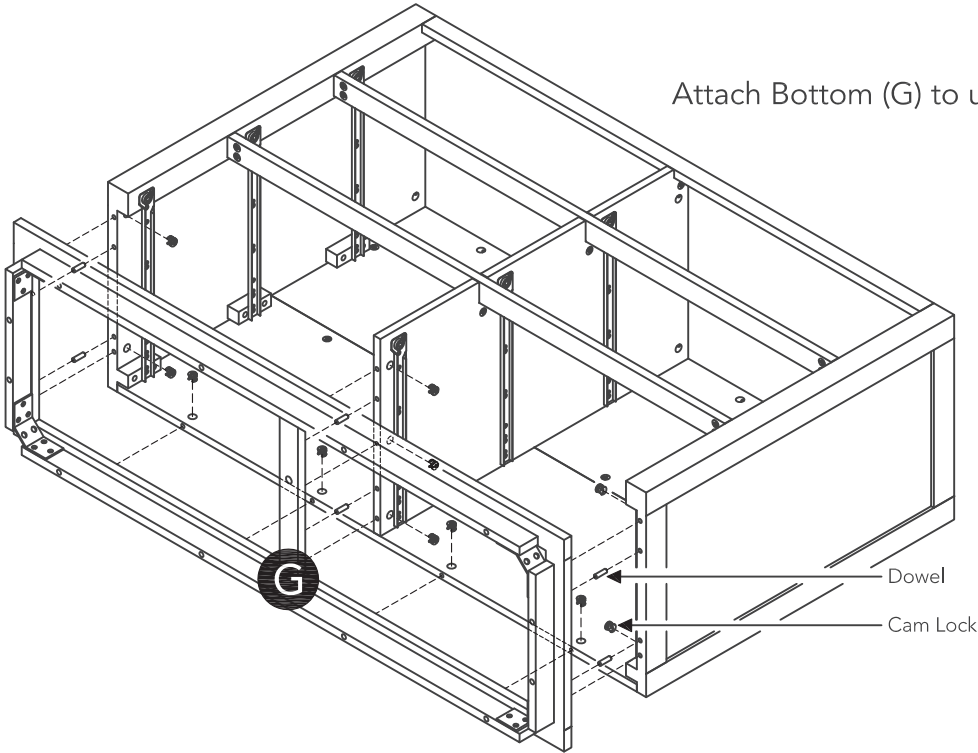

STEP 7

Attach Feet (I), to unit with Head Cap Bolts, Spring Washers and Flat Washers.

Tighten Head Cap Bolts with Hex Wrench. (See Figure 2)

Attach Center Leg (J) to unit.

Assembly Instructions 6/11

STEP 8

Turn unit to its upright position.

Attach Top (A) to unit with Cam Locks and Dowels.

Level unit by adjusting the adjustable levelers on bottom of unit. (See Figure 3)

Note: Unit must be level to proceed.

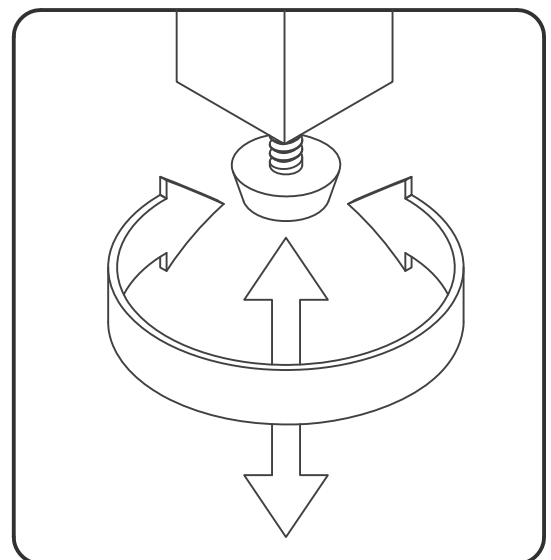
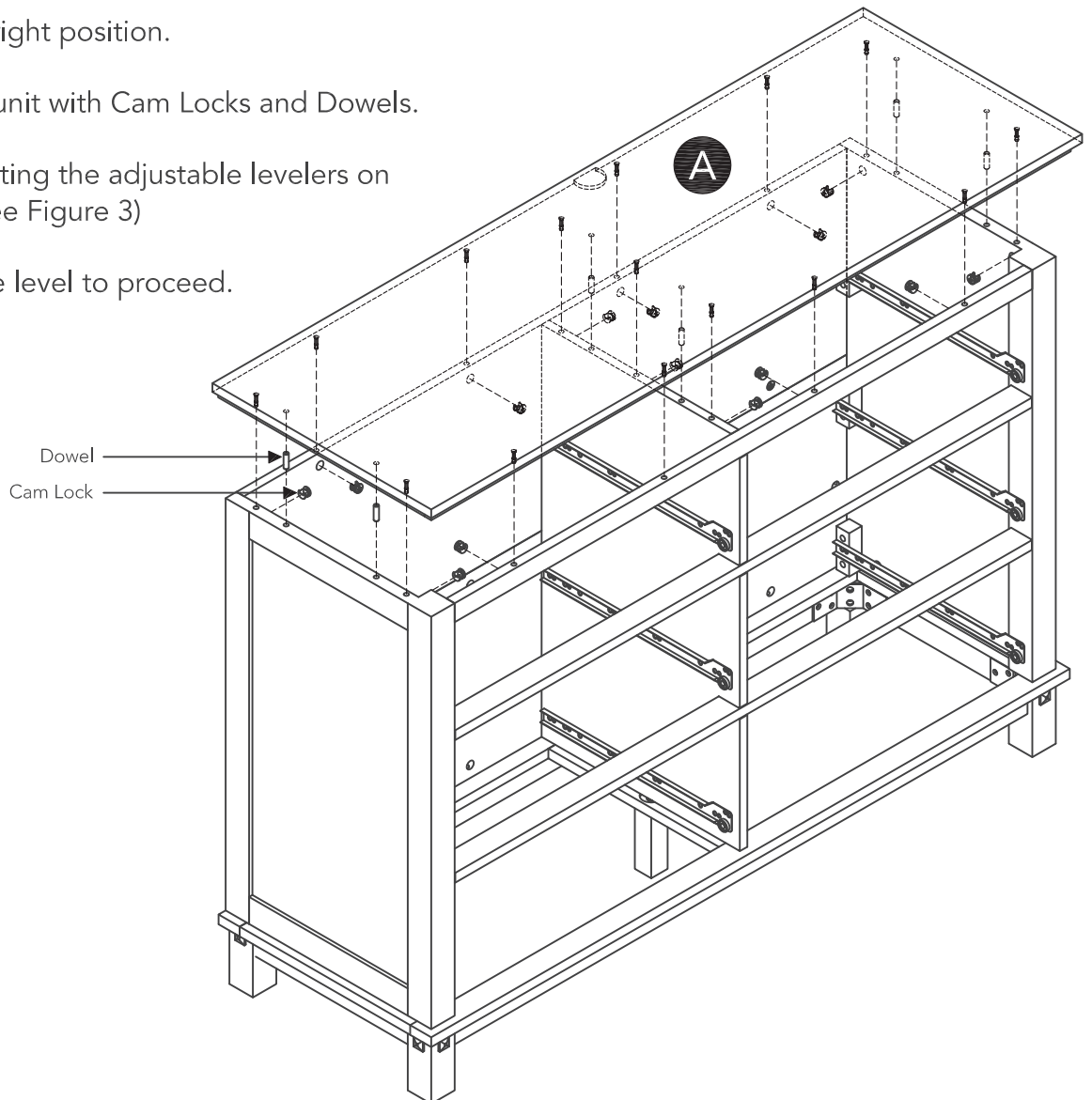

Figure 3

Assembly Instructions 7/11

IMPORTANT

- To help reduce the risk of the unit tipping over, the Tipover Restraint must be installed following these instructions exactly.

STEP 9

Place unit at desired location.

Mark wall with pencil just above and in-line with hole in Top (A). (See Figure 4)

Move unit.

Drill a 3/8" hole in wall 1 1/2" below mark.

Insert Anchor into the wall hole and attach Tipover Restraint to Anchor with 1 1/2" Round Head Screw and Flat Washer. (See Figure 5)

Move unit back into place and insert Tipover Restraint into unit through hole in Top (A). (See Figure 6)

Attach Tipover Restraint to unit with 1/2" Round Head Screw and Flat Washer. (See Figure 7)

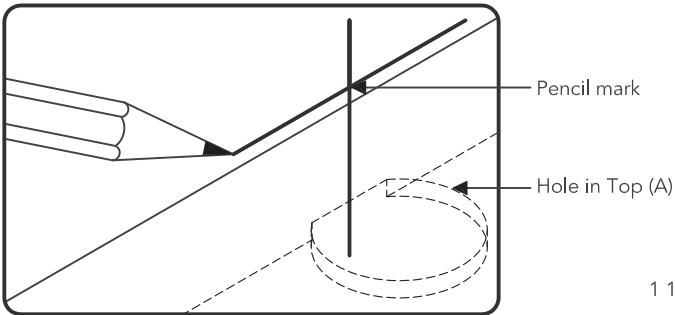
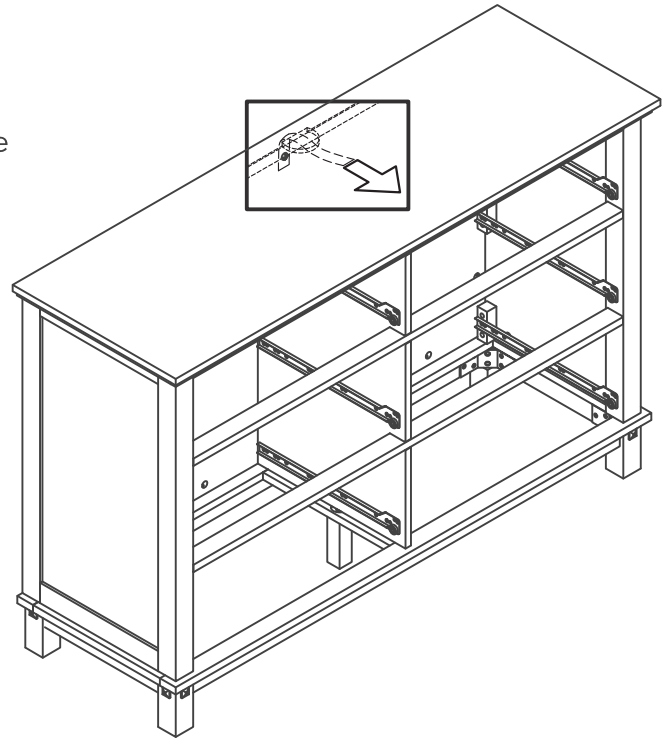

Figure 4

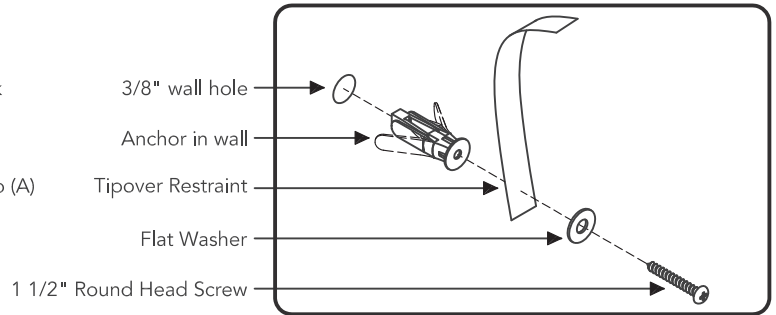

Figure 5

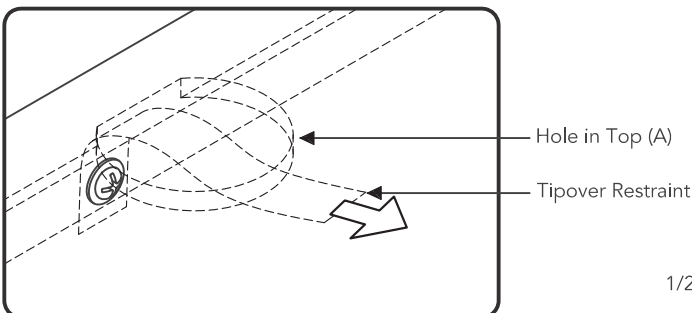

Figure 6

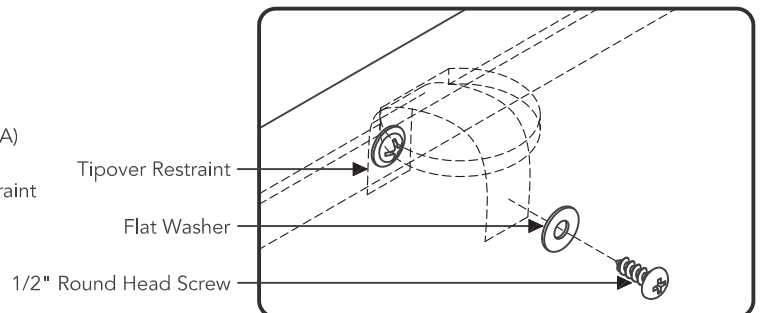
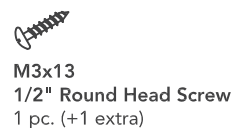
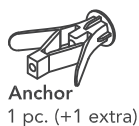

Figure 7

Hardware List



Assembly Instructions 8/11

Drawer (K)

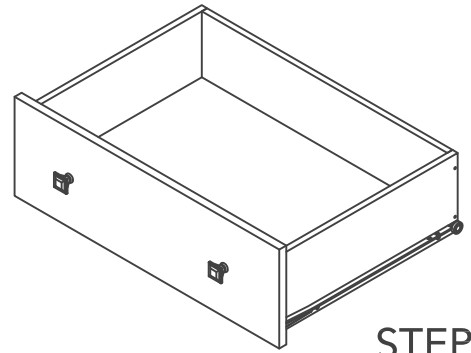
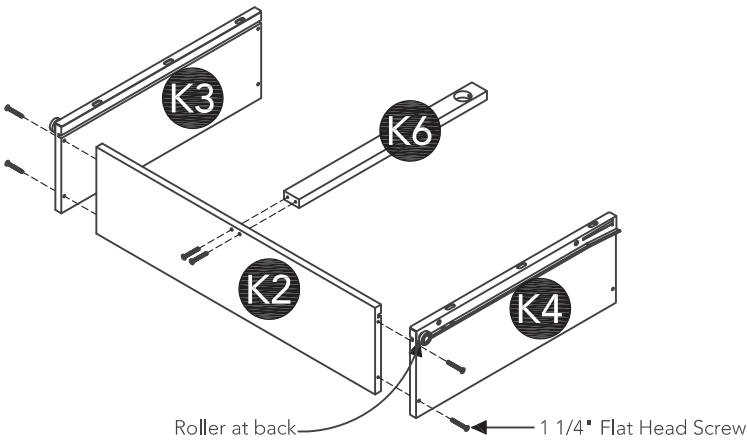

STEP 10

Attach Drawer Sides (K3), (K4) and Drawer Support (K6) to Drawer Back (K2) with 1 1/4" Flat Head Screws.

STEP 11

Insert Drawer Bottom (K5) into groove.

Attach Drawer Front (K1) to unit with 1 1/4" Flat Head Screws.

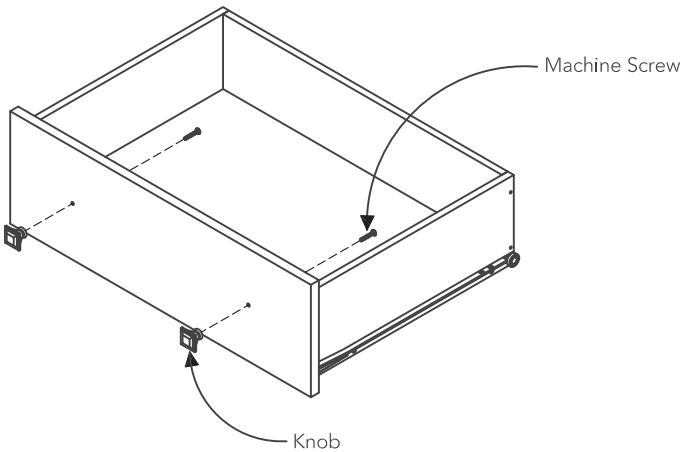
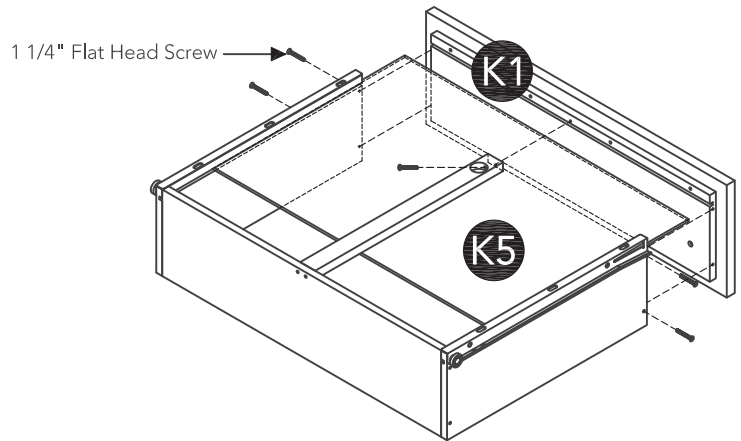

STEP 12

Attach Knobs with Machine Screws.

Note: Drawer assembly is not complete until 3/4" Flat Head Screws are used in a later step.

Part List

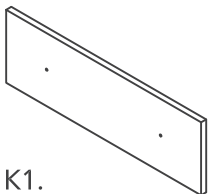

K1.
Drawer Front
2 pcs.

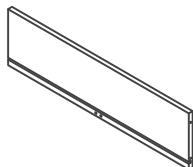

K2.
Drawer Back
2 pcs.

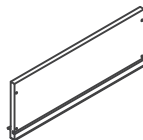

K3.
Drawer Side
2 pcs.

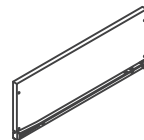

K4.
Drawer Side
2 pcs.

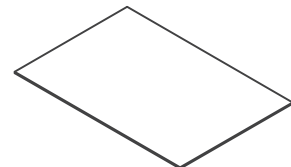

K5.
Drawer Bottom
2 pcs.



K6.
Drawer Support
2 pcs.

Assembly Instructions 9/11

Drawer (L)

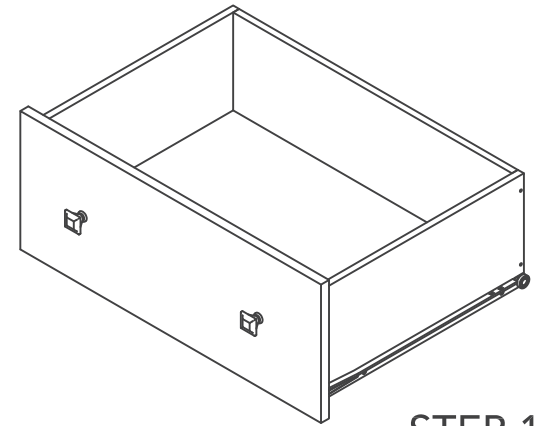
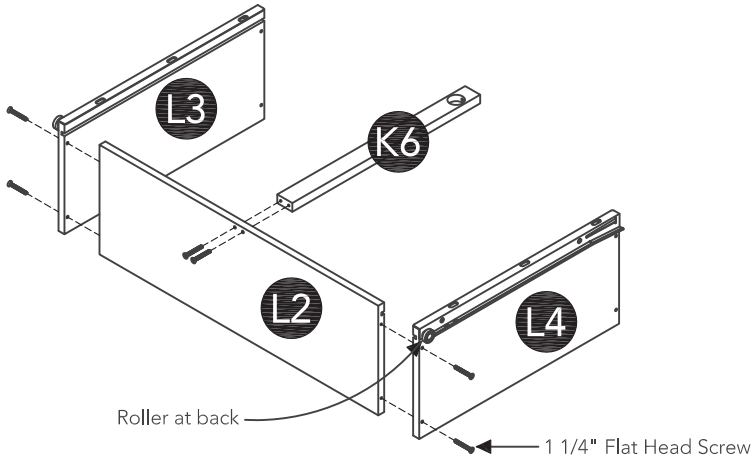

STEP 13

Attach Drawer Sides (L3), (L4) and Drawer Support (K6) to Drawer Back (L2) with 1 1/4" Flat Head Screws.

STEP 14

Insert Drawer Bottom (L5) into groove.

Attach Drawer Front (L1) to unit with 1 1/4" Flat Head Screws.

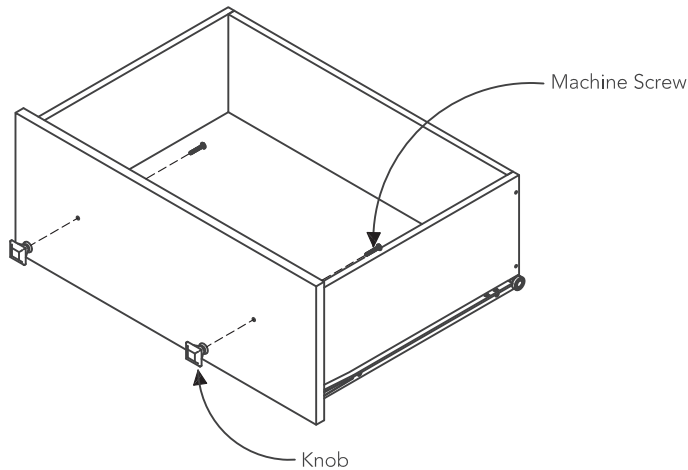
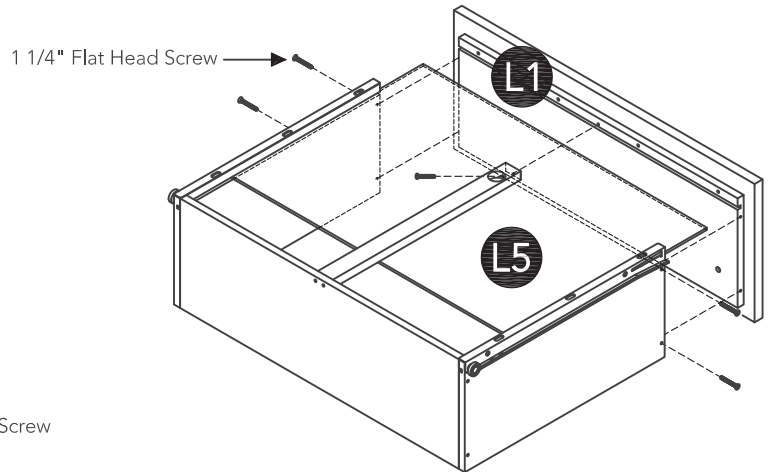

STEP 15

Attach Knobs with Machine Screws.

Note: Drawer assembly is not complete until 3/4" Flat Head Screws are used in a later step.

Part List

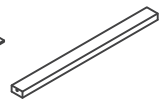
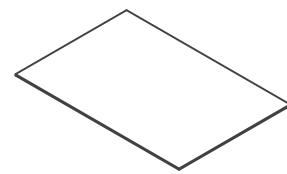
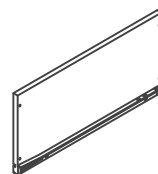
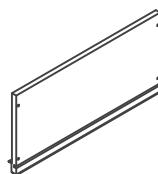
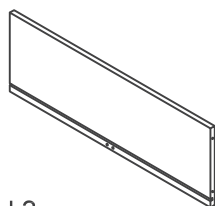
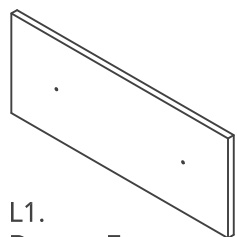

Assembly Instructions 10/11

STEP 16

Loosen slightly screws pre-installed on back of drawer fronts.

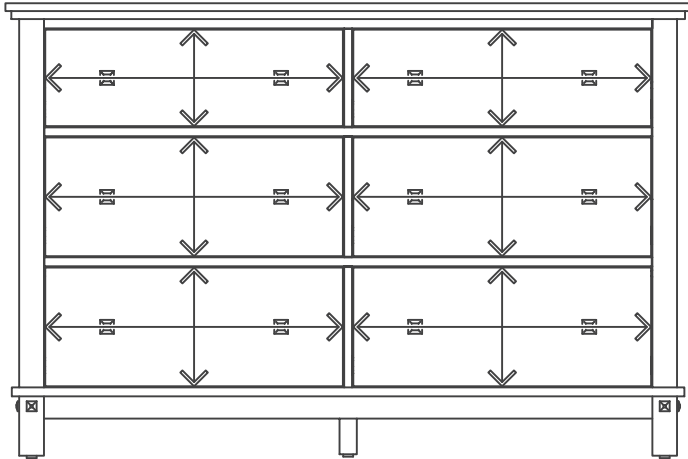
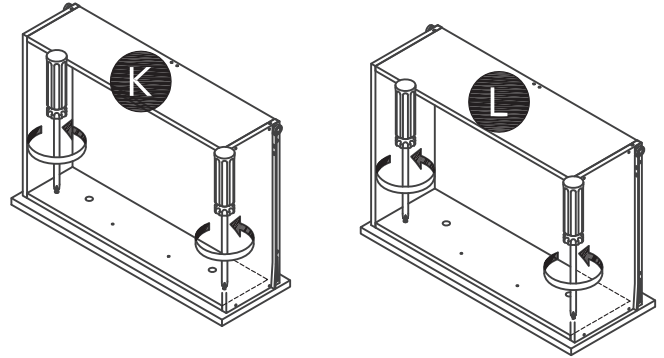

STEP 17

Insert drawers into unit, then adjust drawer front panels left or right and up or down until drawer gaps look proportional.

STEP 18

Pull each drawer open slowly, then re-tighten screws from Step 16.

Make sure drawer front panels do not move and lock drawer front panels into position with 3/4" Flat Head Screws.

Note: These 3/4" Flat Head Screws must be installed to complete the drawer assembly.

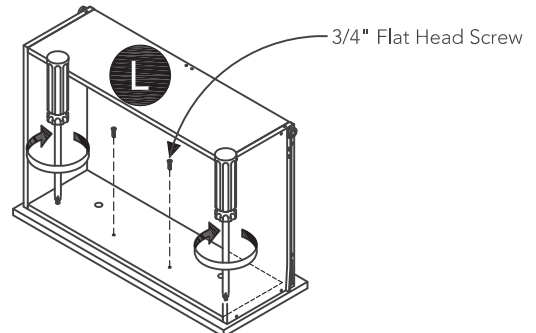
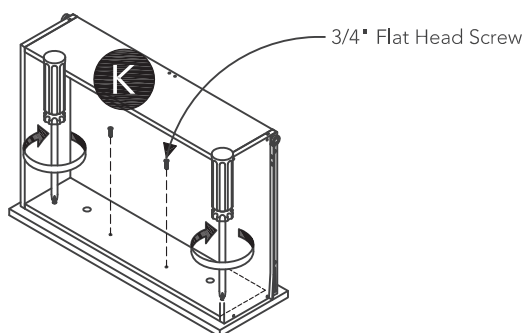
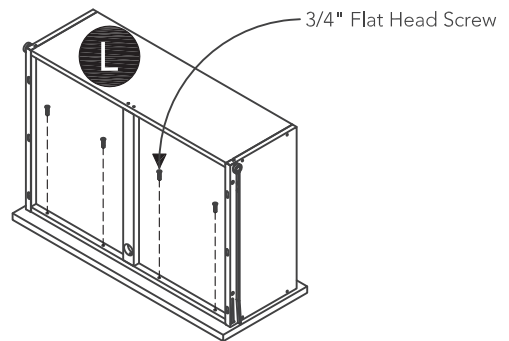
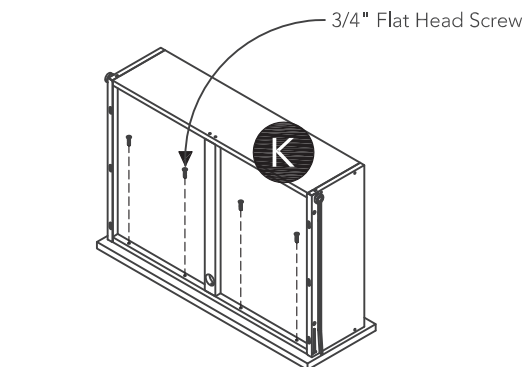

STEP 19

Slide Drawers (K) and (L) into position.

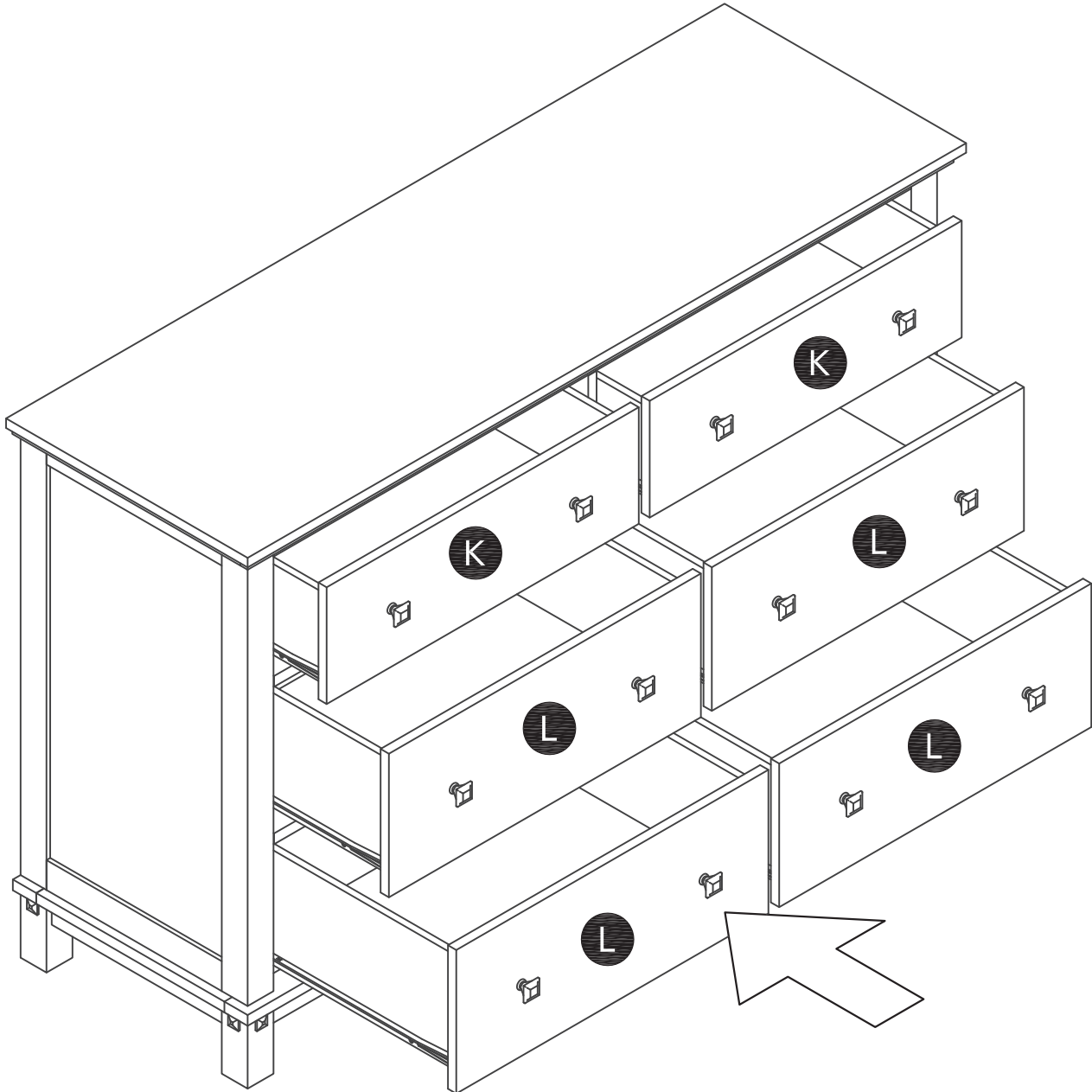

CARE INSTRUCTIONS

NEVER

allow liquids to remain on furniture.
Absorption causes parts to warp
and split and finishes to delaminate.

NEVER

use glass cleaners on
finished furniture. Ammonia
chemically attacks the finish.



Do not use power tools
above 8 volts to assemble.

**PREVENT
CRACKING**

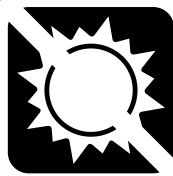

Do not place
in direct sunlight.

**PREVENT
FADING**



Do not write
directly on surface.

**PREVENT
MARKING**



Do not place hot
objects on surface.

**PREVENT
FINISH DAMAGE**

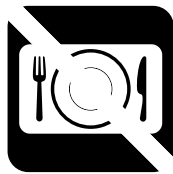

Do not use rubber
based placemats.

**PREVENT
DISCOLORING**



Do not use commercial
waxes and polishes.

**PREVENT
YELLOWING**

CLEAN

with a soft cloth moistened
in lukewarm soap and water.
Buff with a dry clean cloth.



homestyles will provide replacements free of charge for missing or damaged parts within 30 days of purchase. Digital images of the defective parts may be required. If the product was not purchased from an authorized retailer, **homestyles** is under no obligation to provide replacement parts. Parts are not available for fully assembled items nor are parts available for sale. Replacements for missing or damaged parts may be requested via contact info below.

homestyles Customer Service: www.homestylesfurniture.com,
servicedesk@homestylesfurniture.com, 888-680-7460

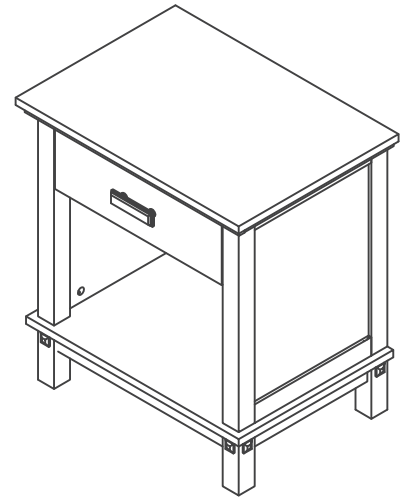

IMPORTANT

Carefully remove all the parts from the carton and place them individually on a soft cloth to prevent scratches or other damage.

Carefully and strictly follow these assembly instructions to ensure a completed product as designed.

Do not use power tools above 8 volts to assemble.

Part List

<p>A. Top 1 pc.</p>	<p>D. Rail 1 pc.</p>	<p>E. Bottom 1 pc.</p>	<p>G. Foot 4 pcs.</p>
<p>B. Side Panel 1 pc.</p>	<p>C. Side Panel 1 pc.</p>	<p>F. Back Panel 1 pc.</p>	<p>H. Drawer 1 pc.</p>

Refer to later page(s) of these instructions for drawer assembly.

Hardware List

<p>Cam Lock Screw 10 pcs. (+2 extra)</p>	<p>Cam Lock 10 pcs. (+2 extra)</p>	<p>M6x30 Head Cap Bolt 8 pcs. (+1 extra)</p>	<p>Spring Washer 8 pcs. (+1 extra)</p>	<p>Flat Washer 8 pcs. (+1 extra)</p>
<p>Hex Wrench 1 pc.</p>	<p>Small Hex Wrench 1 pc.</p>	<p>M3x32 1 1/4" Round Head Screw 2 pcs. (+1 extra)</p>	<p>M3x13 1/2" Round Head Screw 12 pcs. (+1 extra)</p>	<p>M3x32 1 1/4" Flat Head Screw 8 pcs. (+1 extra)</p>
<p>M3x19 3/4" Flat Head Screw 4 pcs. (+1 extra)</p>	<p>Dowel 8 pcs. (+1 extra)</p>	<p>5/32" x 1" Machine Screw 2 pcs.</p>	<p>Handle 1 pc.</p>	

Tool(s) required for assembly: Phillips screwdriver, Level.

homestyles Customer Service: www.homestylesfurniture.com,
servicedesk@homestylesfurniture.com, 888-680-7460

Assembly Instructions 2/8

IMPORTANT

- Use a soft cloth between these parts and the floor.
- Do not use power tools above 8 volts to assemble.
- Do not tighten all the screws until each part is properly assembled.
- The unit must be level to work properly. Use the included adjustable levelers to level.

STEP 1

Insert Cam Lock Screws into pre-drilled holes in Top (A), Side Panels (B), (C) and Bottom (E), then tighten.

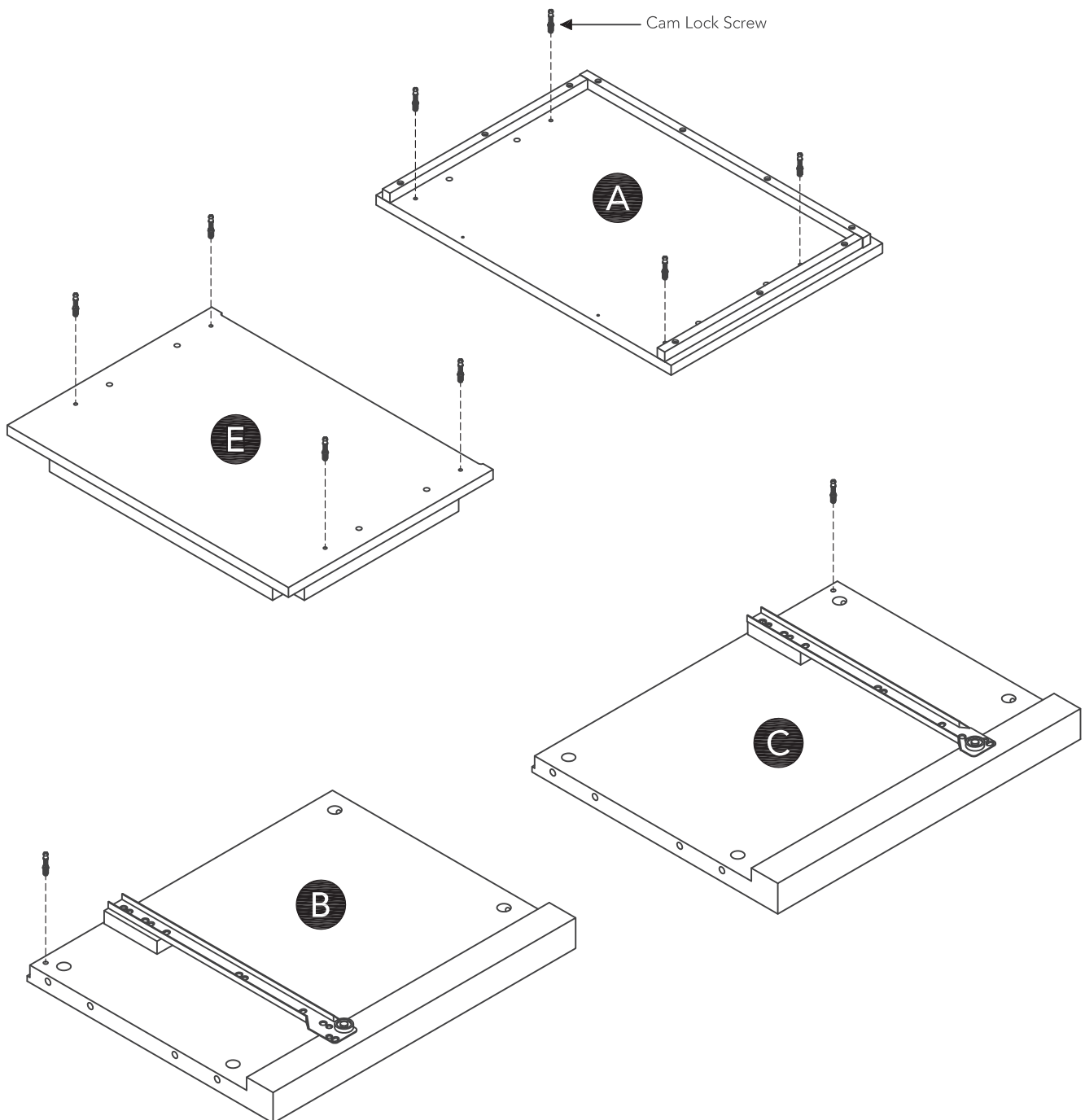

STEP 2

Attach Rail (D) to Side Panels (B) and (C) with Cam Locks.
(See Figure 1)

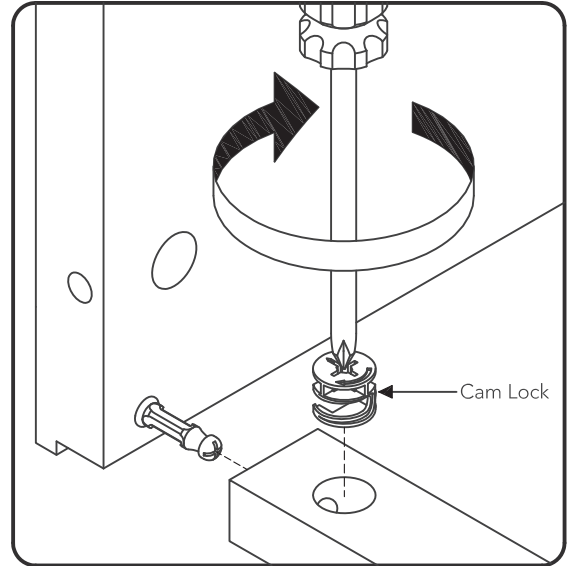
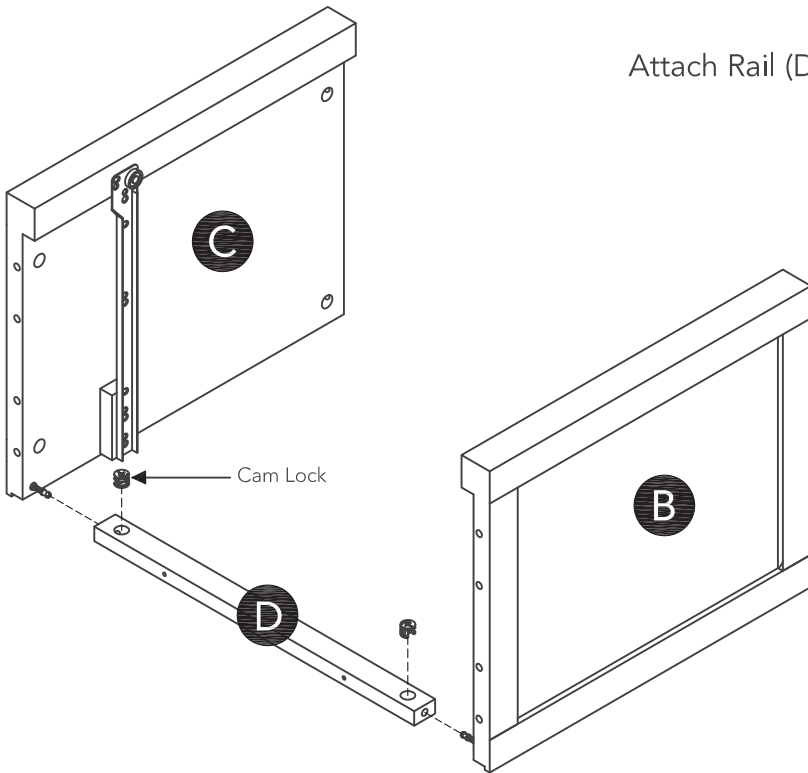
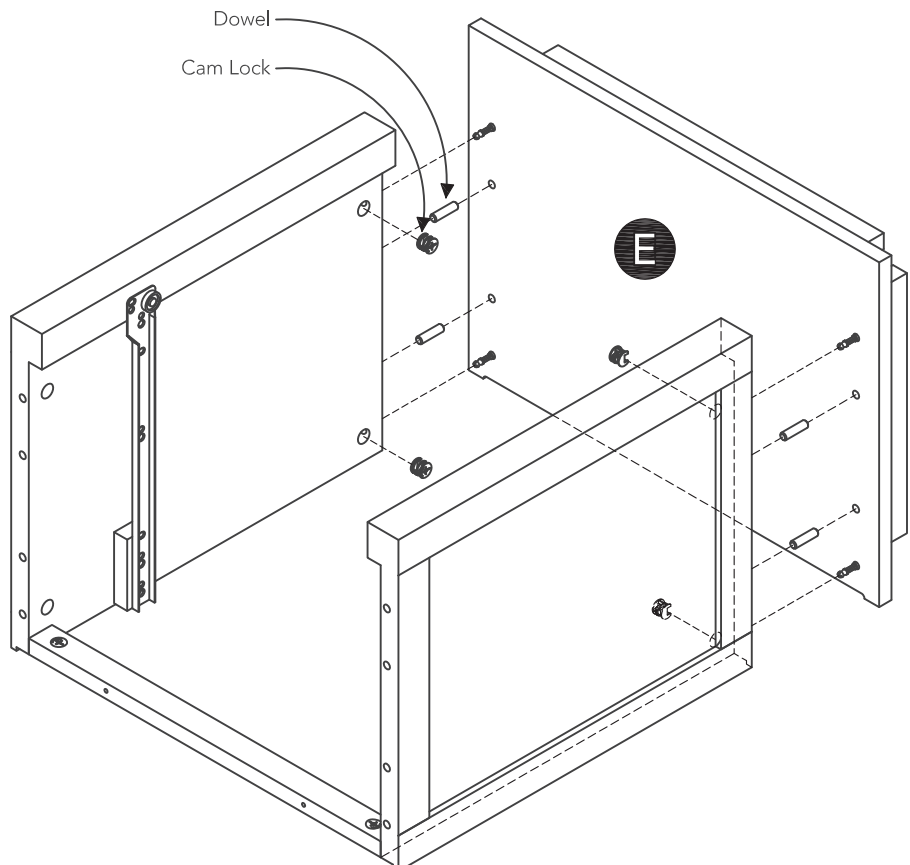

Figure 1



STEP 3

Attach Bottom (E) to unit with Dowels and Cam Locks.

Assembly Instructions 4/8

STEP 4

Attach Top (A) to unit with Dowels and Cam Locks.

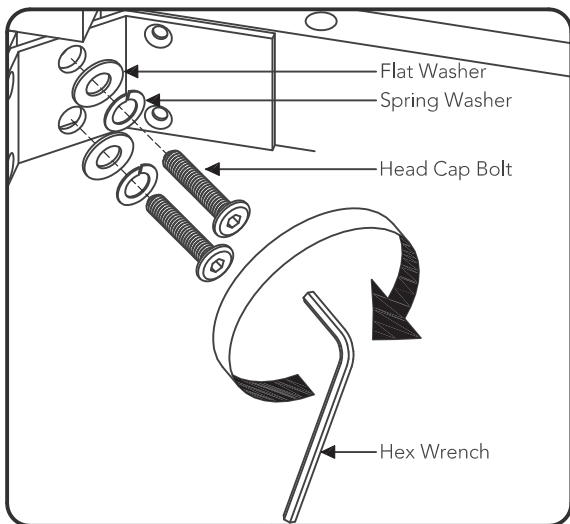
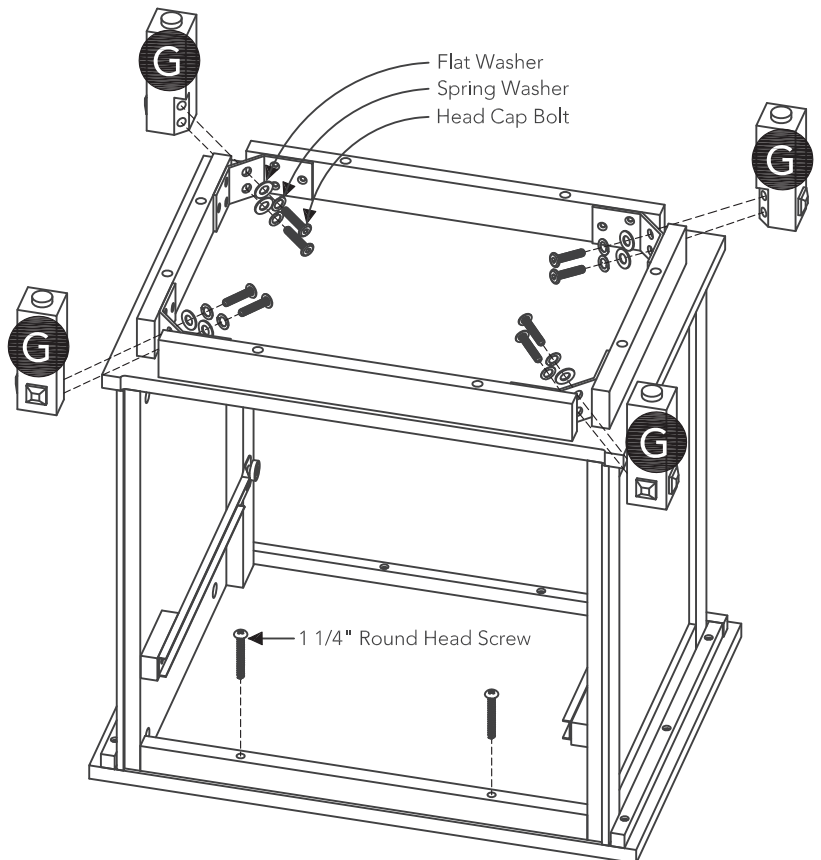
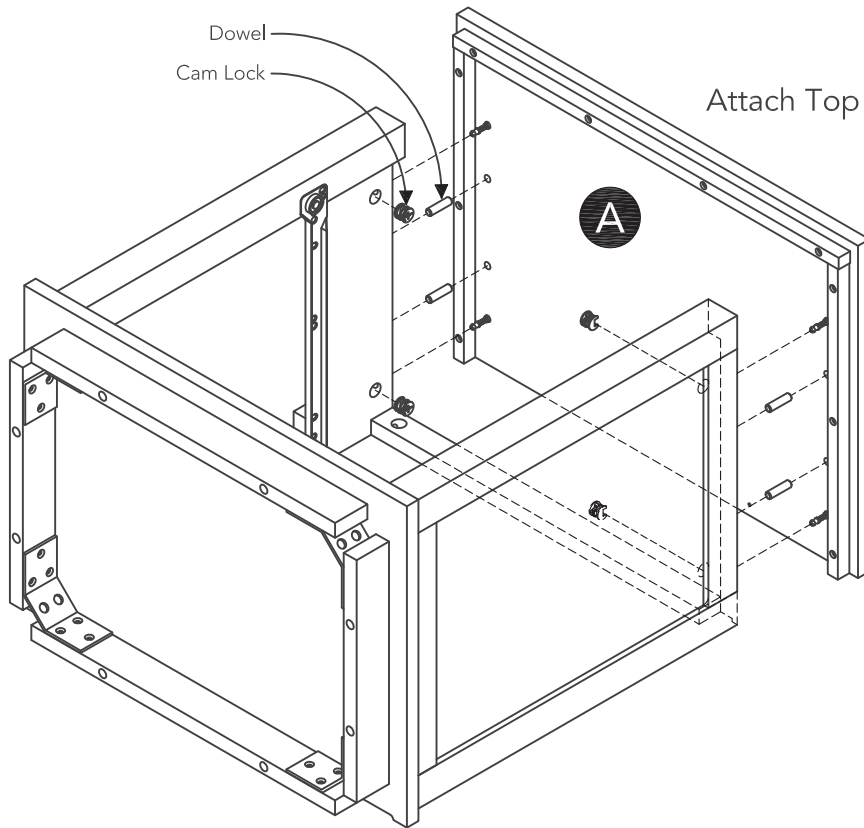

Figure 2

STEP 5

Attach Feet (G) to unit with Head Cap Bolts, Spring Washers and Flat Washers.

Tighten Head Cap Bolts with Hex Wrench. (See Figure 2)

Attach 1 1/4" Round Head Screws to unit.

Assembly Instructions 5/8

STEP 6

Turn unit to its upright position.

Level unit by adjusting the adjustable levelers on bottom of unit. (See Figure 3)

Note: Unit must be level to proceed.

Attach Back Panel (F) to unit with 1/2" Round Head Screws. (See Figure 4)

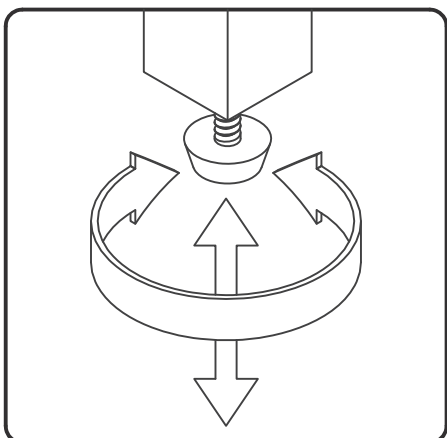
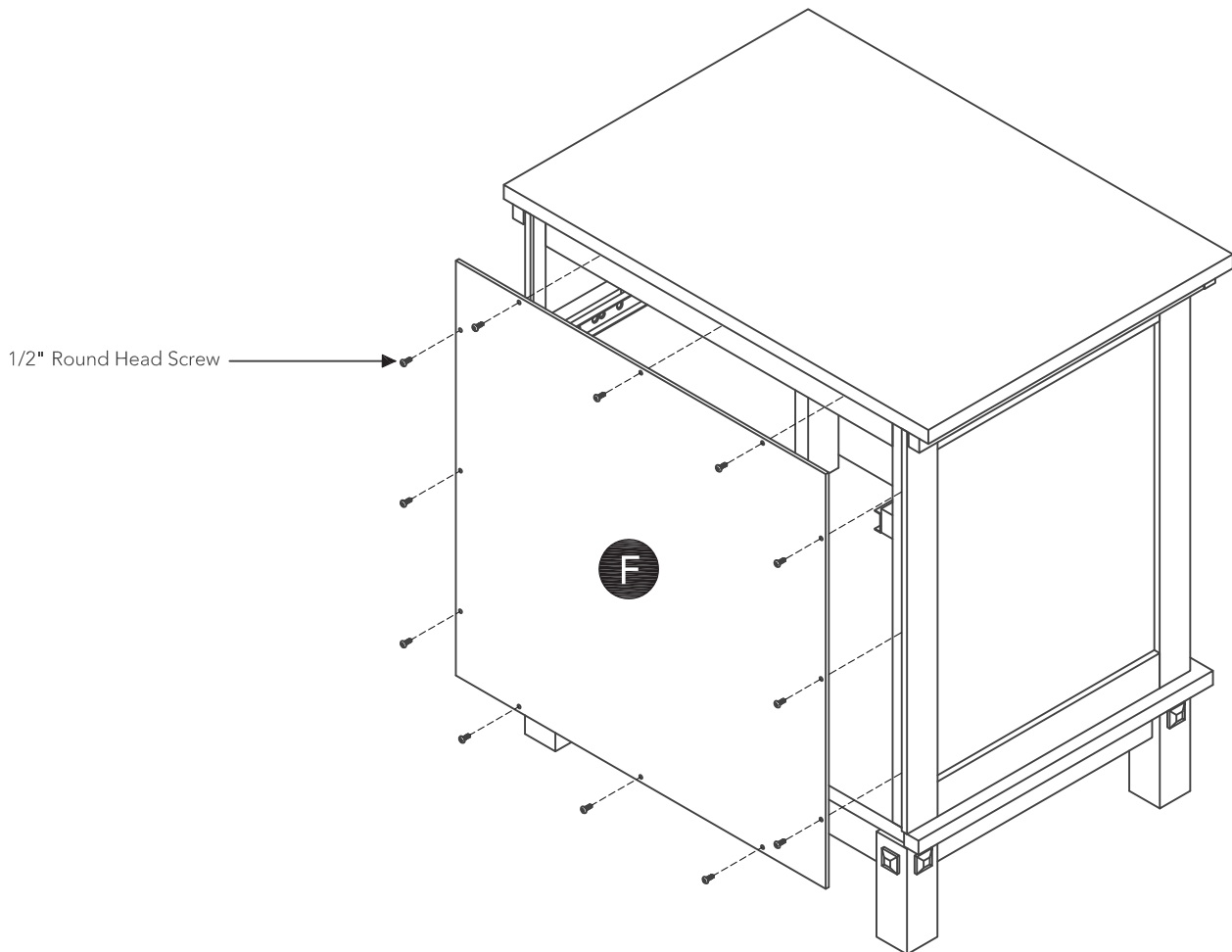

Figure 3

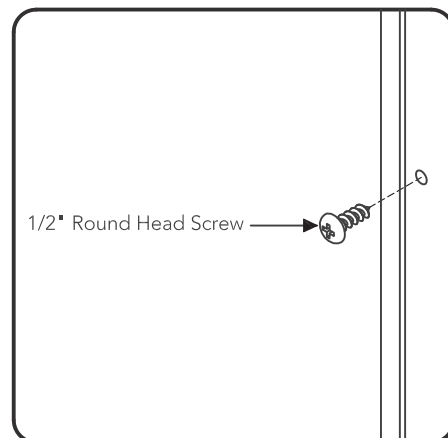
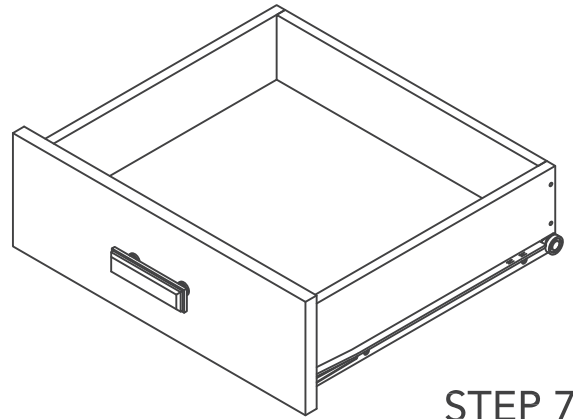
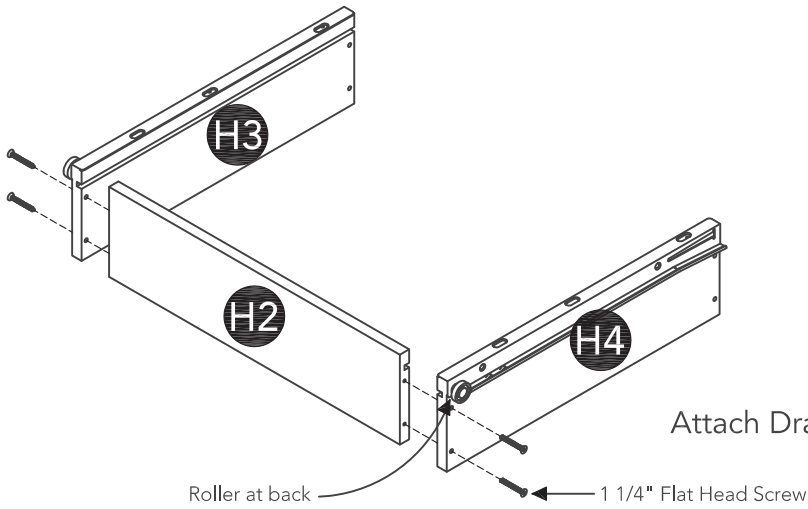

Figure 4

Assembly Instructions 6/8

Drawer (H)



STEP 7

Attach Drawer Sides (H3) and (H4) to Drawer Back (H2) with 1 1/4" Flat Head Screws.

STEP 8

Insert Drawer Bottom (H5) into groove.

Attach Drawer Front (H1) to unit with 1 1/4" Flat Head Screws.

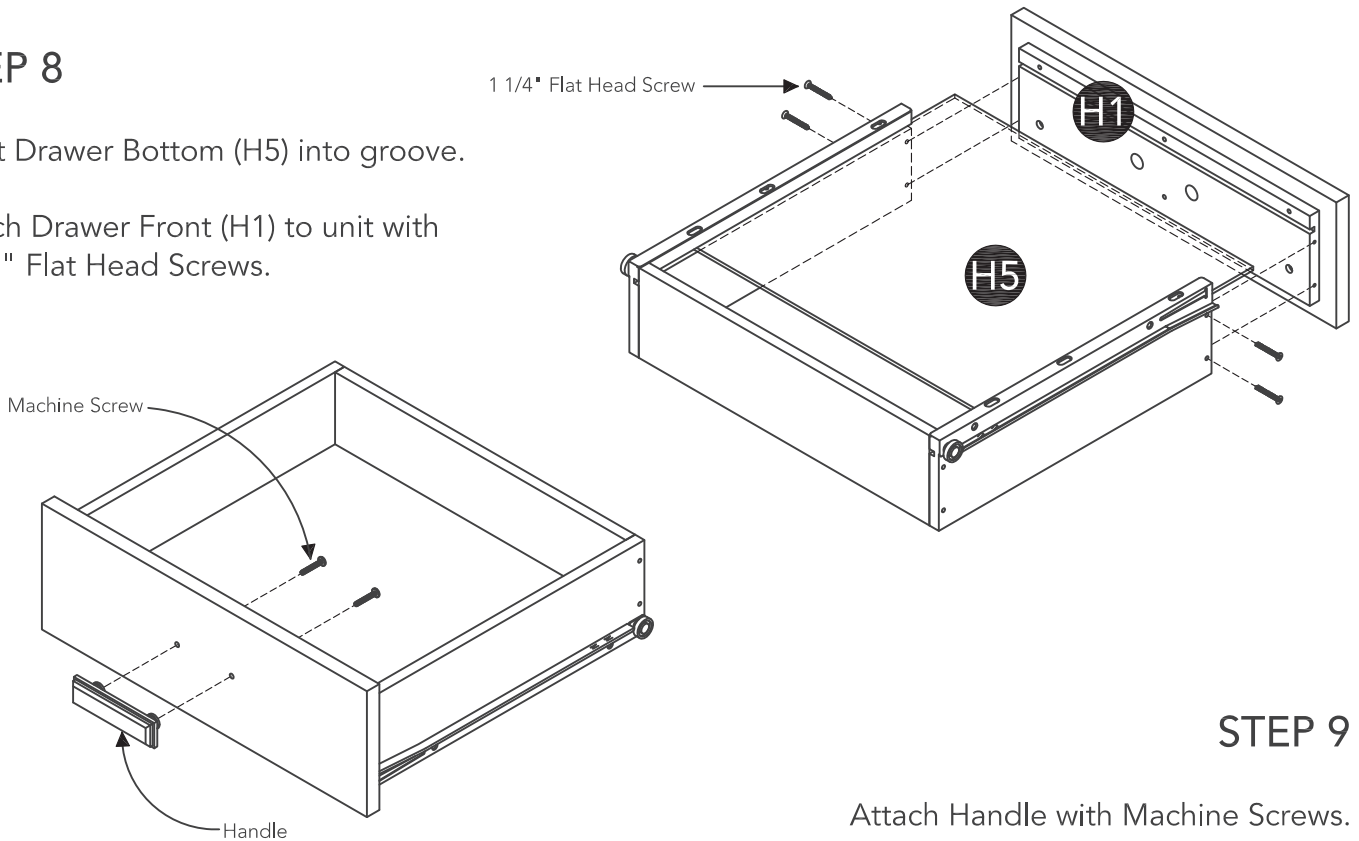

STEP 9

Attach Handle with Machine Screws.

Note: Drawer assembly is not complete until 3/4" Flat Head Screws are used in a later step.

Part List

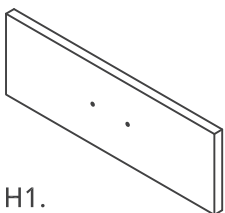

H1.
Drawer Front
1 pc.

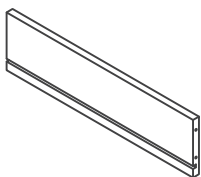

H2.
Drawer Back
1 pc.

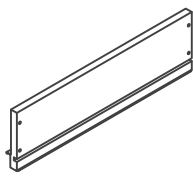

H3.
Drawer Side
1 pc.

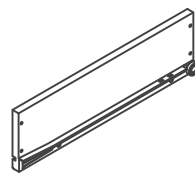

H4.
Drawer Side
1 pc.

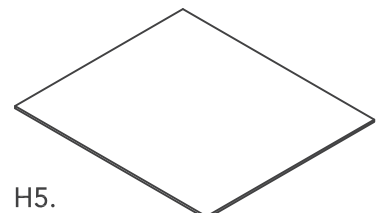

H5.
Drawer Bottom
1 pc.

Assembly Instructions 7/8

STEP 10

Loosen slightly screws pre-installed on back of drawer front.

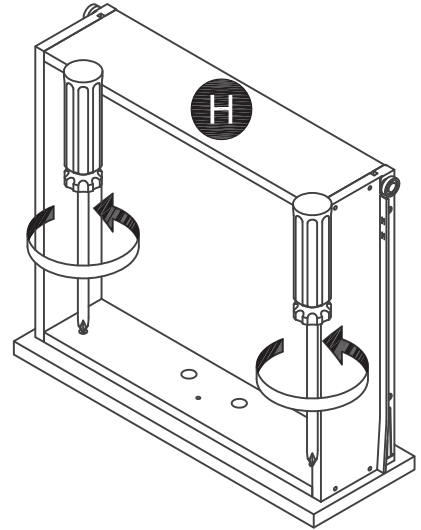
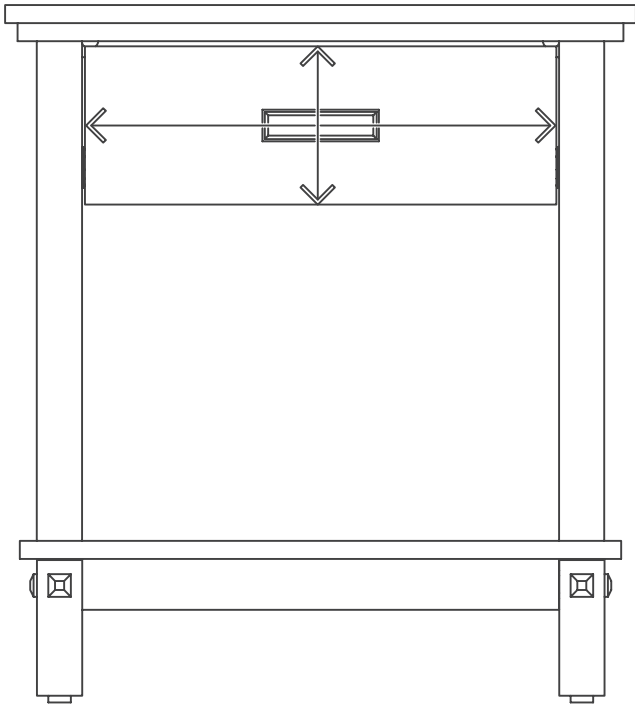

STEP 11

Insert drawer into unit, then adjust drawer front panel left or right and up or down until drawer gaps look proportional.

STEP 12

Pull drawer open slowly, then re-tighten screws from Step 10.

Make sure drawer front panel does not move and lock drawer front panel into position with 3/4" Flat Head Screws.

Note: These 3/4" Flat Head Screws must be installed to complete the drawer assembly.

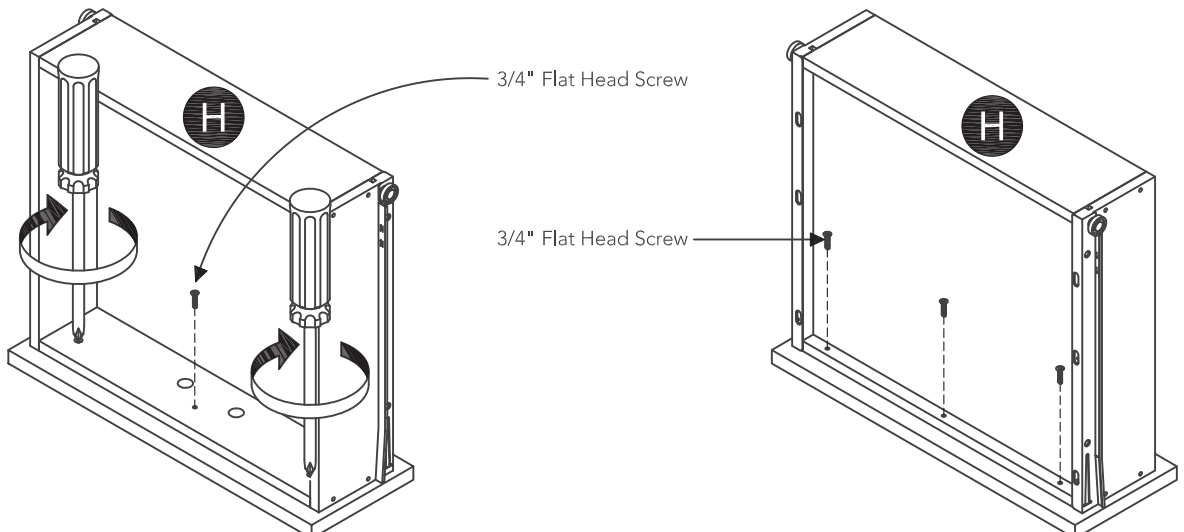

STEP 13

Slide Drawer (H) into position.

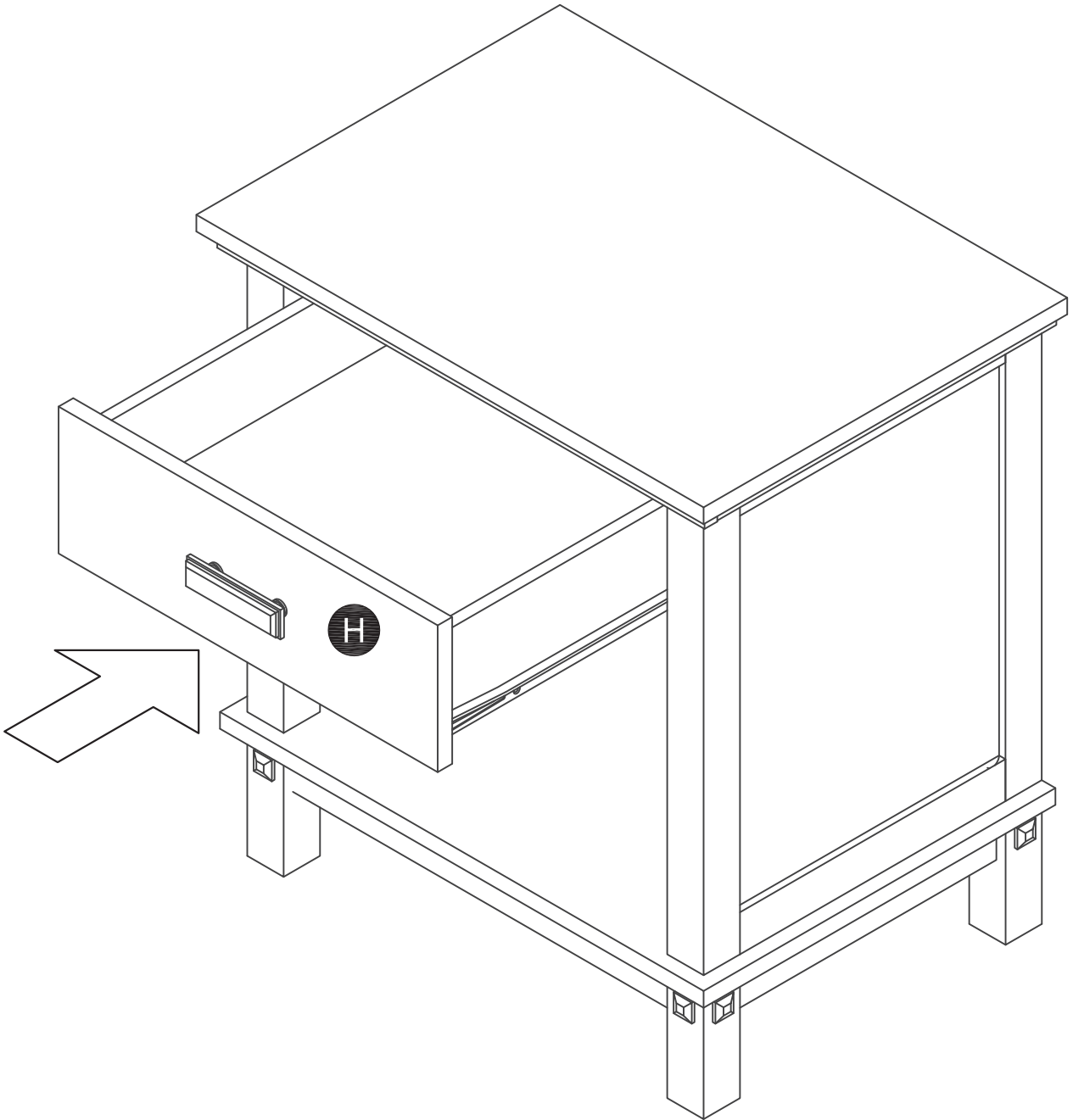

CARE INSTRUCTIONS

NEVER

allow liquids to remain on furniture.
Absorption causes parts to warp
and split and finishes to delaminate.

NEVER

use glass cleaners on
finished furniture. Ammonia
chemically attacks the finish.



Do not use power tools
above 8 volts to assemble.

**PREVENT
CRACKING**

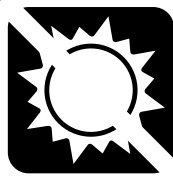

Do not place
in direct sunlight.

**PREVENT
FADING**



Do not write
directly on surface.

**PREVENT
MARKING**



Do not place hot
objects on surface.

**PREVENT
FINISH DAMAGE**

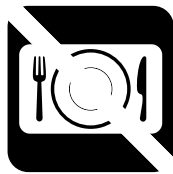

Do not use rubber
based placemats.

**PREVENT
DISCOLORING**



Do not use commercial
waxes and polishes.

**PREVENT
YELLOWING**

CLEAN

with a soft cloth moistened
in lukewarm soap and water.
Buff with a dry clean cloth.



homestyles will provide replacements free of charge for missing or damaged parts within 30 days of purchase. Digital images of the defective parts may be required. If the product was not purchased from an authorized retailer, **homestyles** is under no obligation to provide replacement parts. Parts are not available for fully assembled items nor are parts available for sale. Replacements for missing or damaged parts may be requested via contact info below.

homestyles Customer Service: www.homestylesfurniture.com,
servicedesk@homestylesfurniture.com, 888-680-7460