

ASSEMBLY INSTRUCTIONS
COASTER FINE FURNITURE

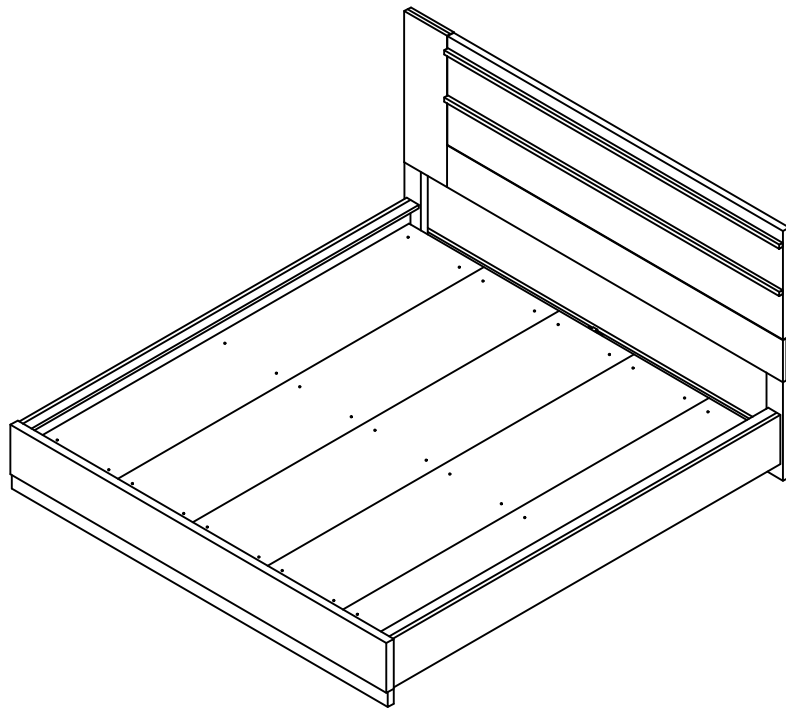

Fine Furniture for every stage of life

224281KW(B1-B3)
California King Bed

ITEM: 224281KW(B1-B3)



ASSEMBLY INSTRUCTIONS

ASSEMBLY TIPS:

1. Remove hardware from box and sort by size.
2. Please check to see that all hardware and parts are present prior to start of assembly.
3. Please follow attached instructions in the same sequence as numbered to assure fast & easy assembly.



WARNING!

1. Don't attempt to repair or modify parts that are broken or defective. Please contact the store immediately.
2. This product is for home use only and not intended for commercial establishments.

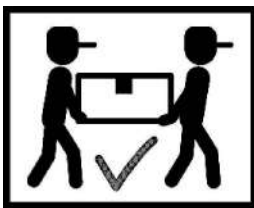

ASSEMBLY TIME

30 MINUTES

PARTS IDENTIFICATION

B1(BOX 1)

A HEADBOARD PANEL

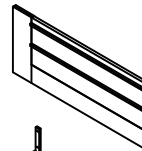

1PC

B LEFT HEADBOARD LEG



1PC

C RIGHT HEADBOARD LEG



1PC

D HEADBOARD BOTTOM RAIL

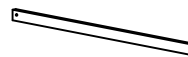

1PC

B2(BOX 2)

E FOOTBOARD



1PC

F ROLL SLAT (10PCS)

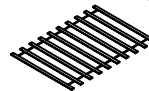

1SET

B3(BOX 3)

G BED RAIL



2PCS

H CENTER RAIL

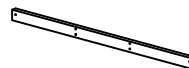

1PC

I CENTER RAIL SUPPORT WITH LEVELER



2PCS

J CONCEAL PANEL



5PCS

K RAIL TOP



2PCS

ITEM: 224281KW(B1-B3)



ASSEMBLY INSTRUCTIONS

ASSEMBLY TIPS:

1. Remove hardware from box and sort by size.
2. Please check to see that all hardware and parts are present prior to start of assembly.
3. Please follow attached instructions in the same sequence as numbered to assure fast & easy assembly.



WARNING!

1. Don't attempt to repair or modify parts that are broken or defective. Please contact the store immediately.
2. This product is for home use only and not intended for commercial establishments.

HB 224281KW(B1)
FROM BOX 1
HEADBOARD COMPLETE

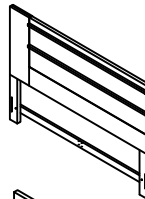

1PC

E 224281KW(B2)
FROM BOX 2
FOOTBOARD

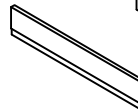

1PC

HARDWARE IDENTIFICATION

Z-B3(BOX 3) - HARDWARE PACK IS LOCATED IN 224281KW(B3)

1	ALLEN WRENCH (M4 x 110mm - BLK)		1PC
2	BOLT WITH WASHER (M6 x 50mm - BLK)		16PCS
3	PAN HEAD SCREW (M4 x 12mm - BLK)		30PCS
4	SHORT FLAT HEAD SCREW (M4 x 20mm - BLK)		8PCS
5	LONG FLAT HEAD SCREW (#8 x 1 1/8" - BLK)		20PCS
6	HEX NUT (M6 - RBW)		2PCS
7	U BRACKET (26 x 63 x 70mm - RBW)		2PCS
8	WRENCH (2 x 24.5 x 85mm - RBW)		1PC
9	WOOD DOWEL (M8 x 30mm)		8PCS
10	LONG BOLT WITH WASHER (M6 x 60mm - BLK)		8PCS

NOTE:

Phillips head screw driver is required in the assembly process; however, manufacturer does not provide this item.

ITEM: **224281KW(B1-B3)**



ASSEMBLY INSTRUCTIONS

STEP 1

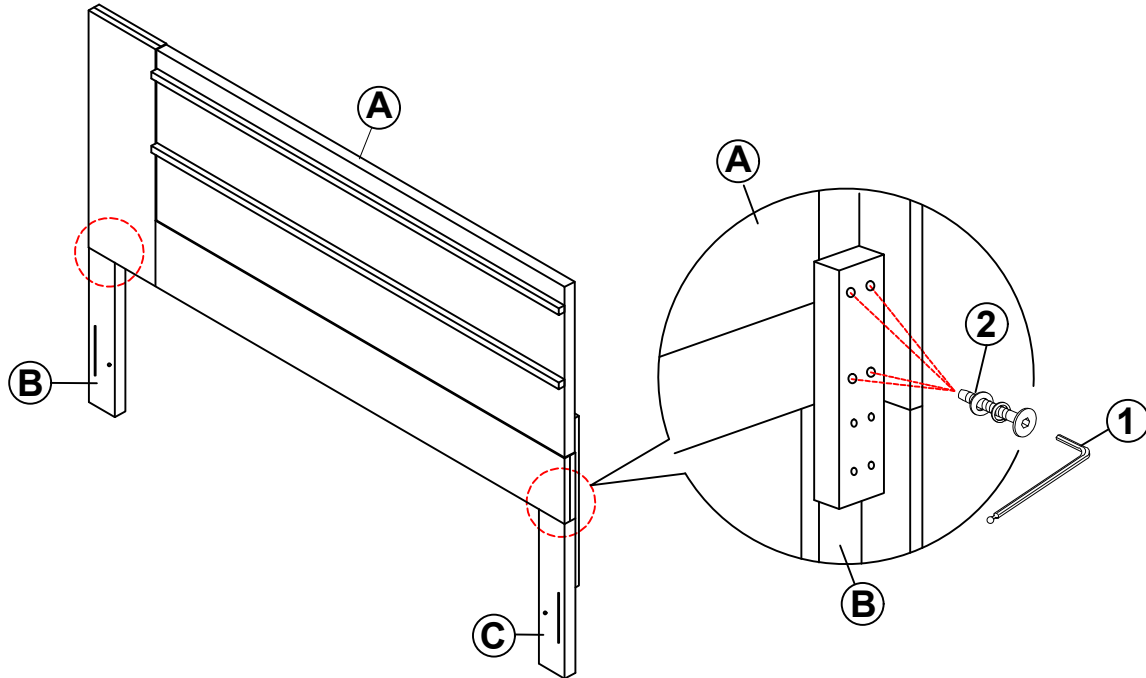

STEP 2

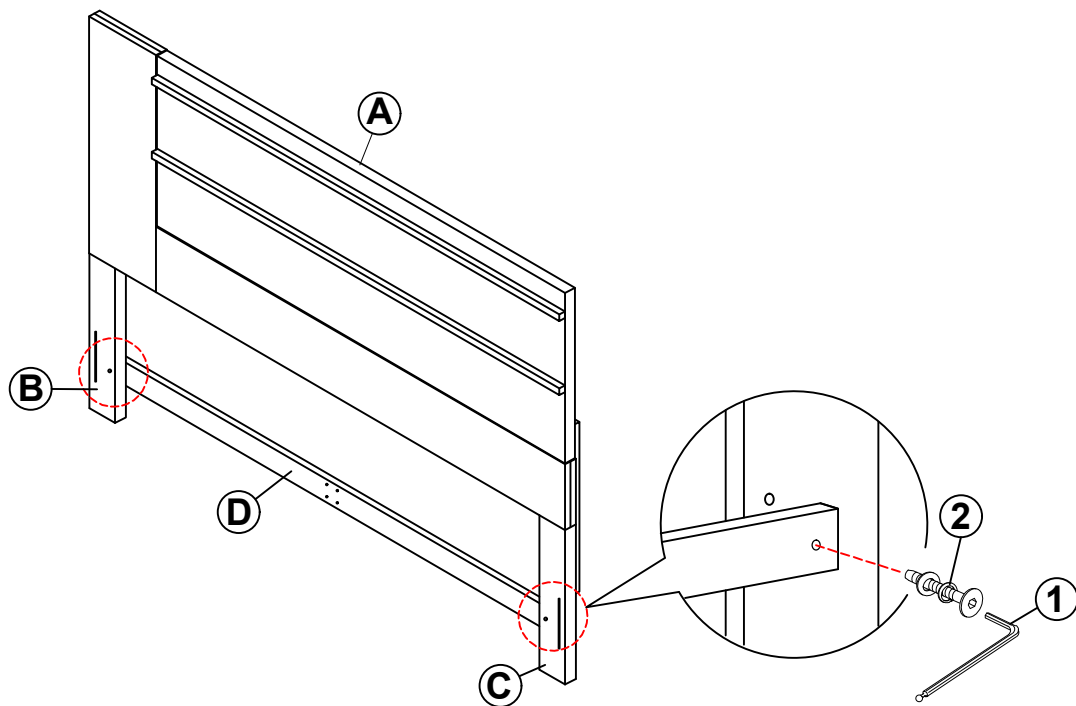

ITEM: **224281KW(B1-B3)**



ASSEMBLY INSTRUCTIONS

STEP 3

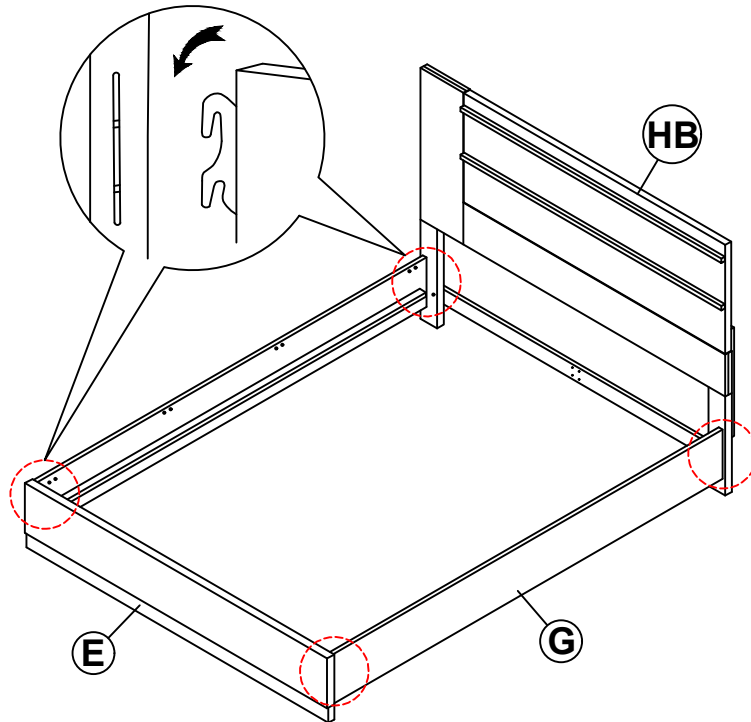

STEP 4

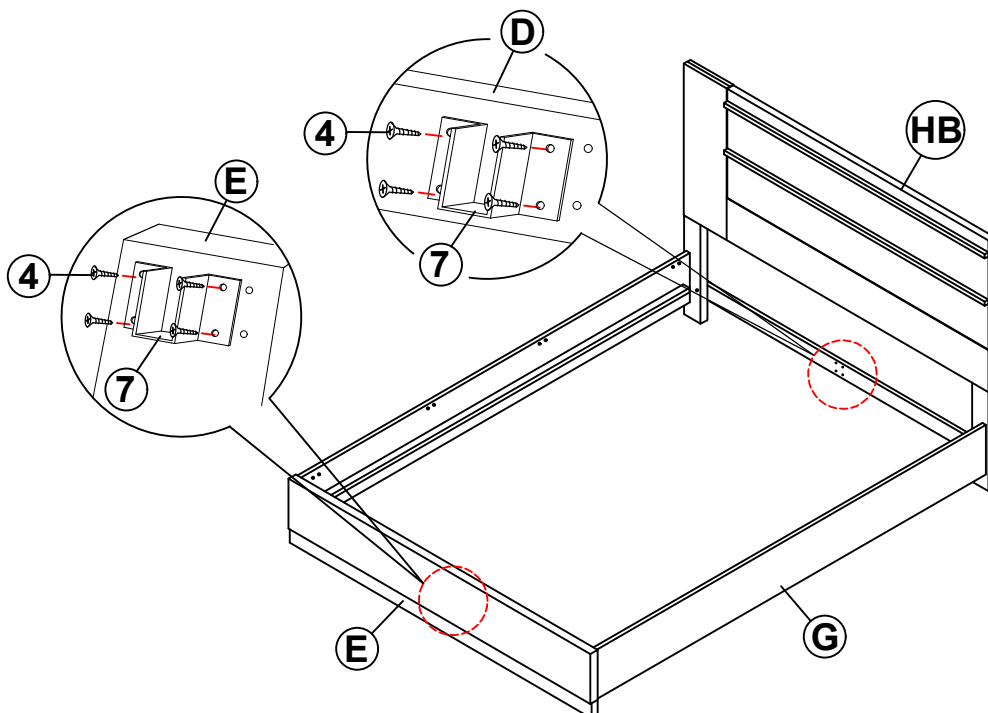

ITEM: **224281KW(B1-B3)**



ASSEMBLY INSTRUCTIONS

STEP 5

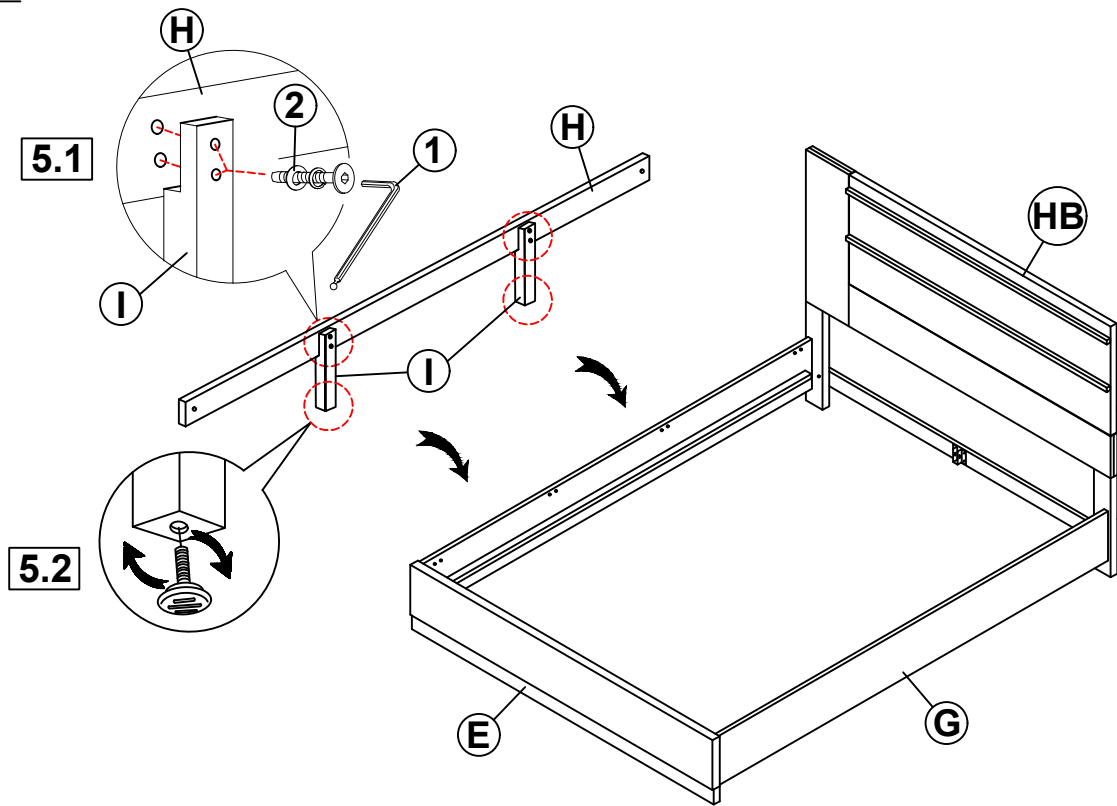

STEP 6

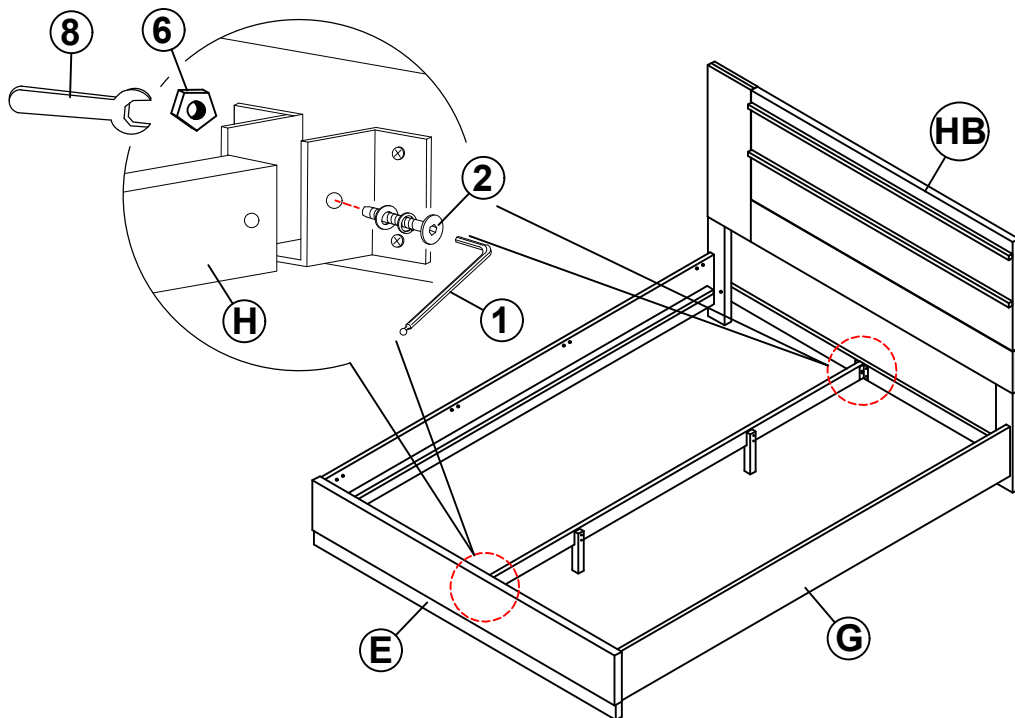

ITEM: **224281KW(B1-B3)**



ASSEMBLY INSTRUCTIONS

STEP 7

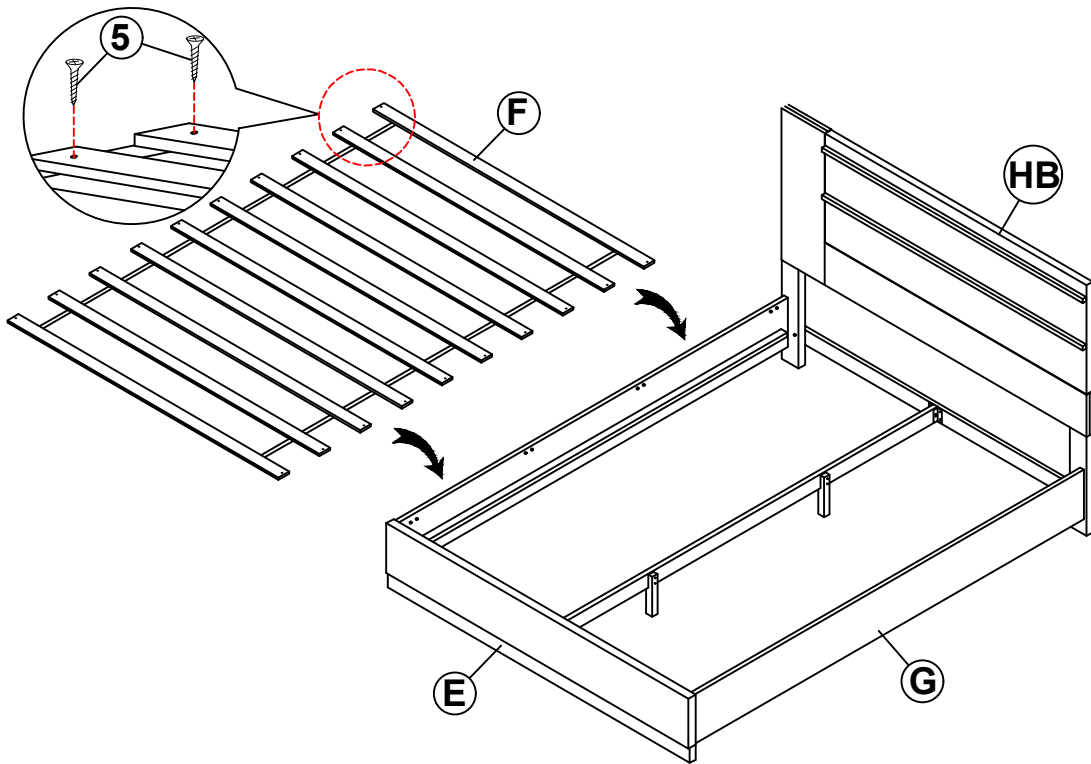

STEP 8

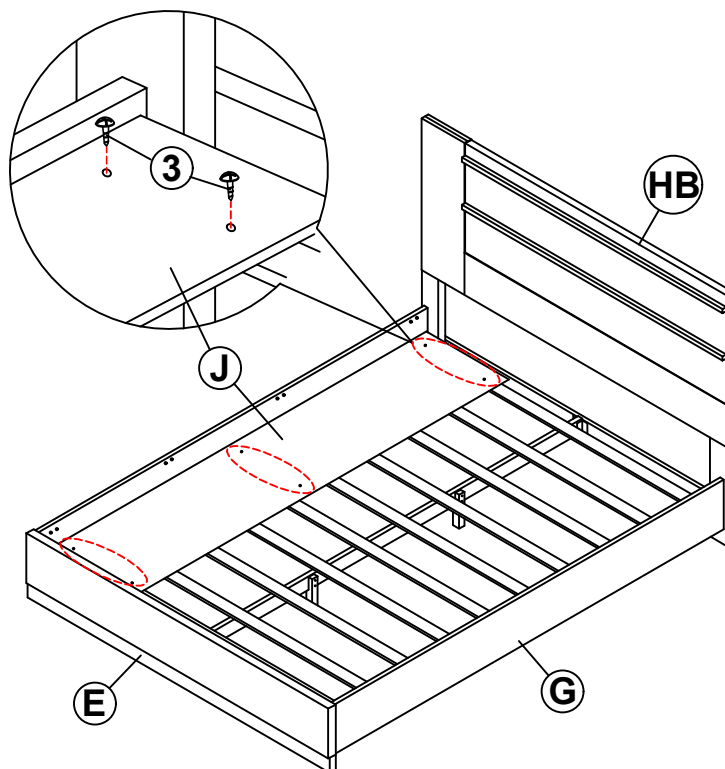

ITEM: **224281KW(B1-B3)**



ASSEMBLY INSTRUCTIONS

STEP 9

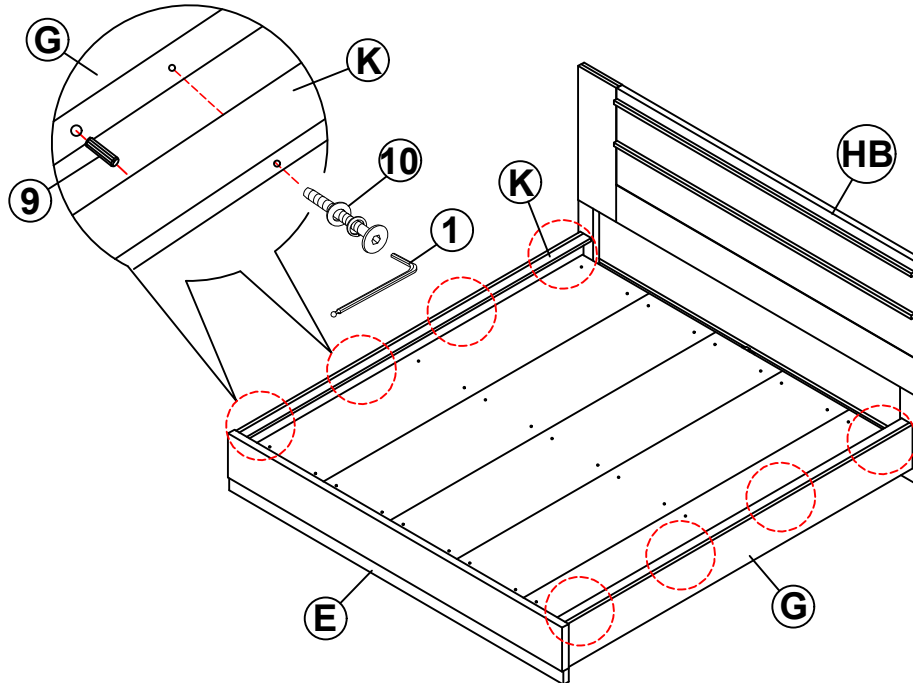

**STEP 10
COMPLETE**

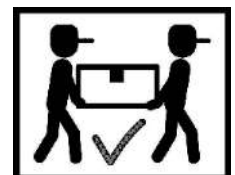
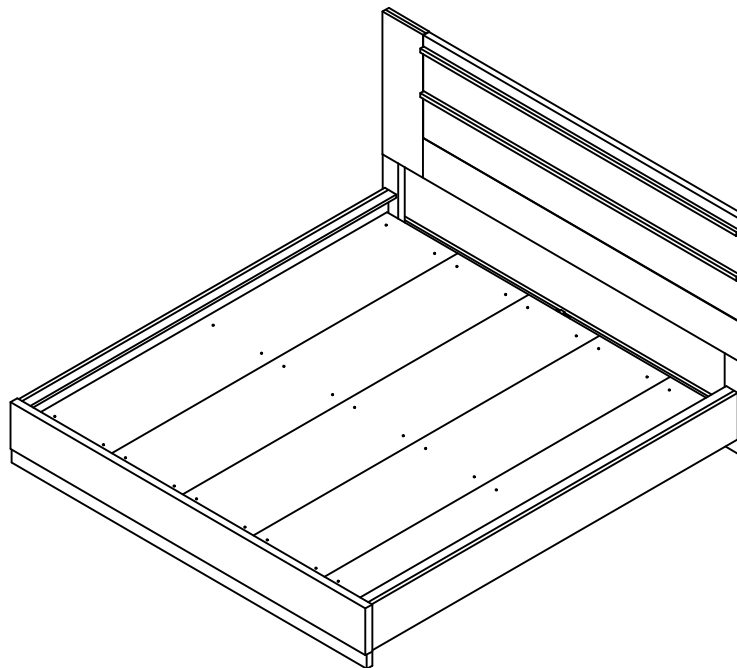

ITEM: 224281KW(B1-B3)

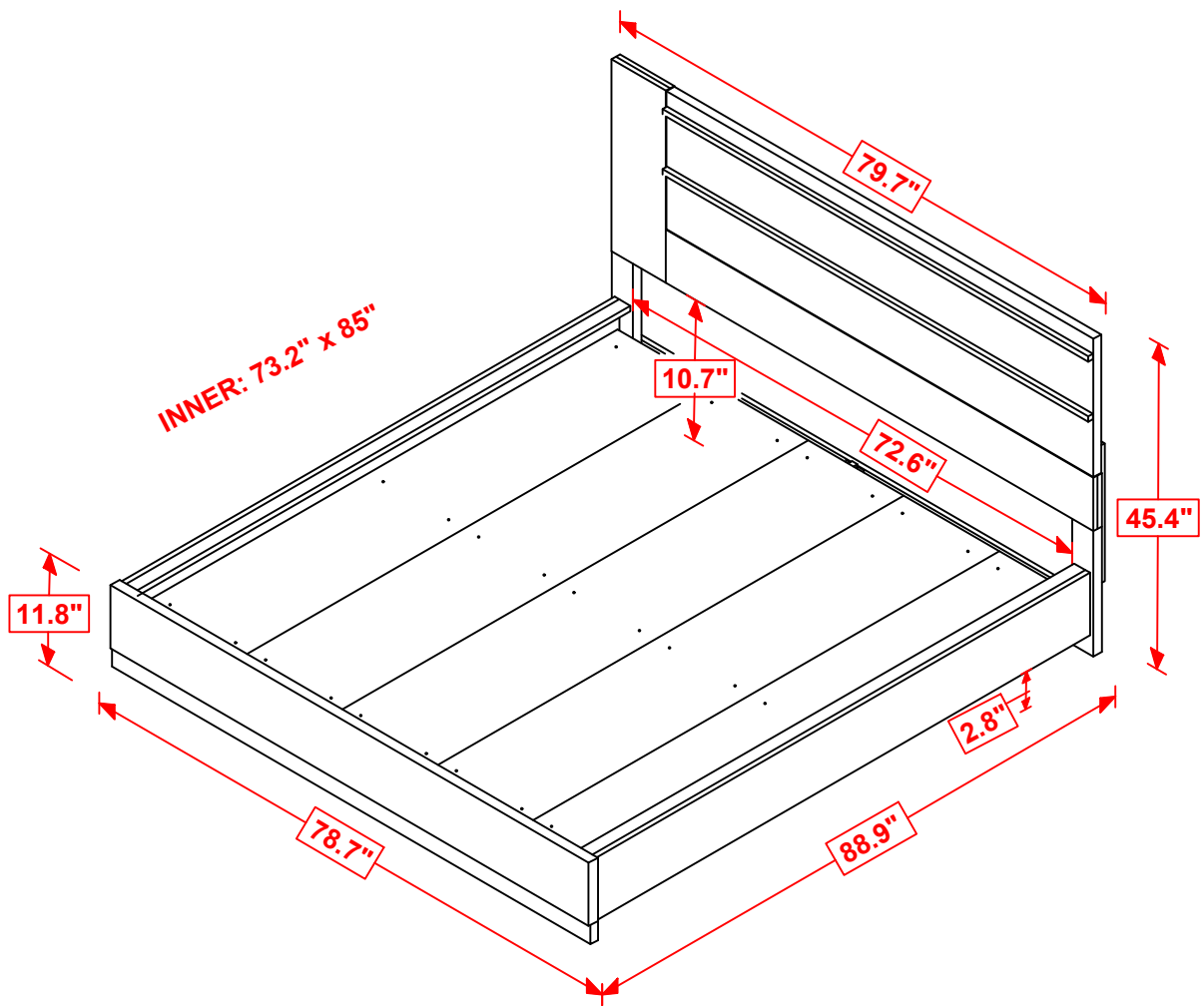

NOTE : DIMENSION TOLERANCE \pm 5%

COASTERFURNITURE.COM