



# ASSEMBLY INSTRUCTIONS COASTER FINE FURNITURE



## 193811 DINING TABLE

ITEM: 193811

# ASSEMBLY INSTRUCTIONS

## ASSEMBLY TIPS:

1. Remove hardware from box and sort by size.
2. Please check to see that all hardware and parts are present prior to start of assembly.
3. Please follow attached instructions in the same sequence as numbered to assure fast & easy assembly.



### WARNING!

1. Don't attempt to repair or modify parts that are broken or defective. Please contact the store immediately.
2. This product is for home use only and not intended for commercial establishments.

**ASSEMBLY TIME 30 MINUTES**

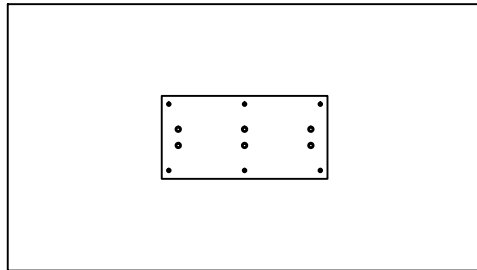

A TOP 1PC

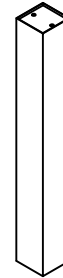



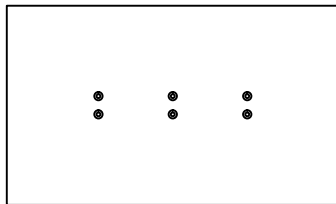



C PILLAR 3PCS



B BASE 1PC

## HARDWARE IDENTIFICATION

Z	HARDWARE NAME	FIGURE	QTY
1	BOLT	 M8*20	6PCS
2	BOLT	 M8*25	6PCS
3	BOLT	 M8*50	6PCS
4	FLAT WASHER		6PCS
5	SPRING WASHER		6PCS
6	ALLEN WRENCH	 M5	1PC
7	RUBBER PAD	 80*80	3PCS

ITEM:193811

# ASSEMBLY INSTRUCTIONS



## STEP 1

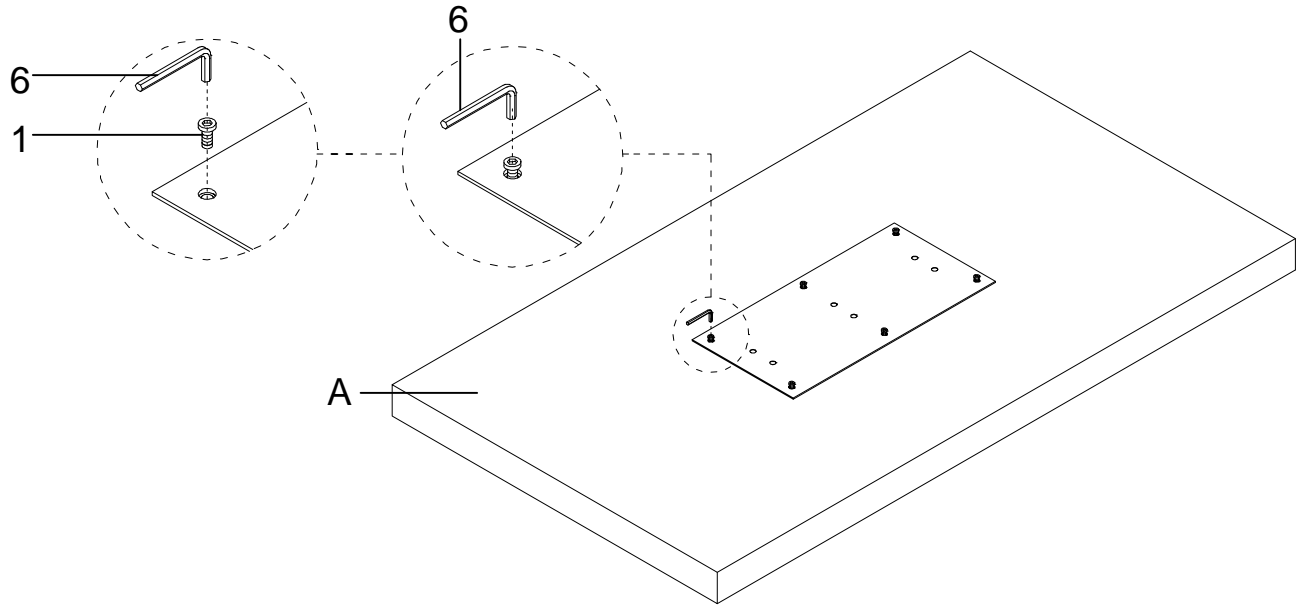

## STEP 2

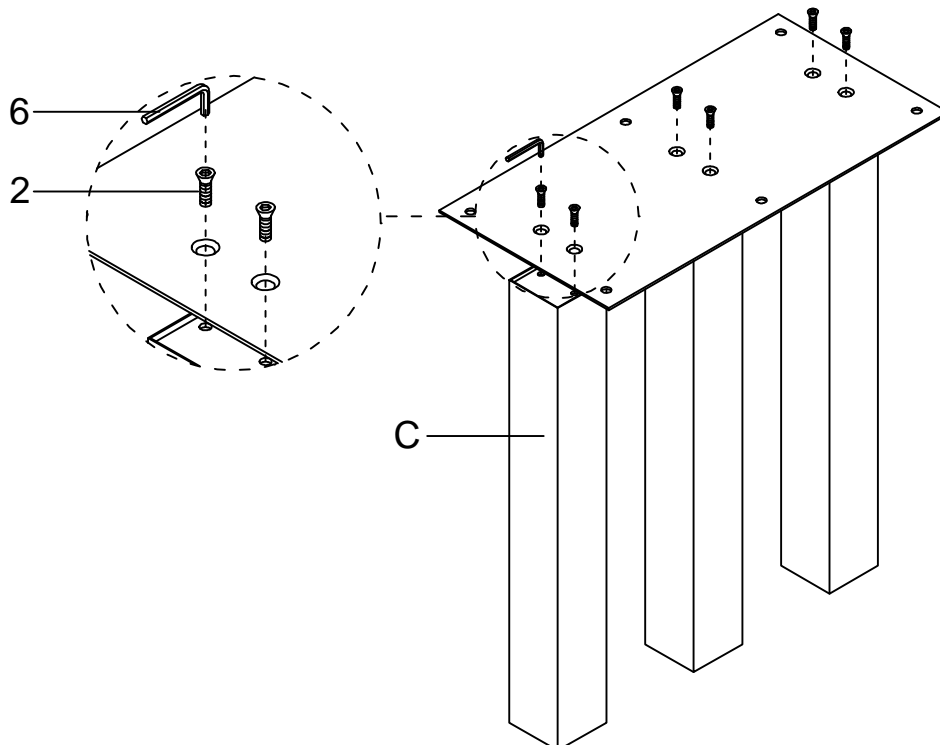

ITEM:193811

ASSEMBLY INSTRUCTIONS



STEP 3

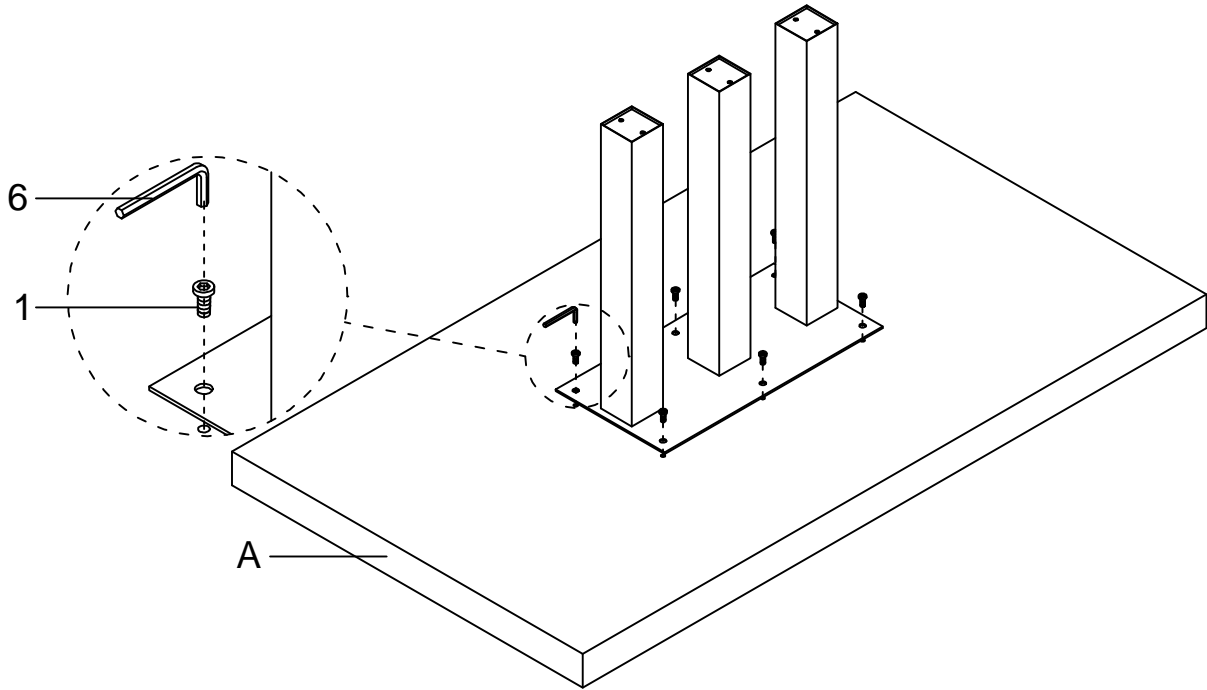

STEP 4

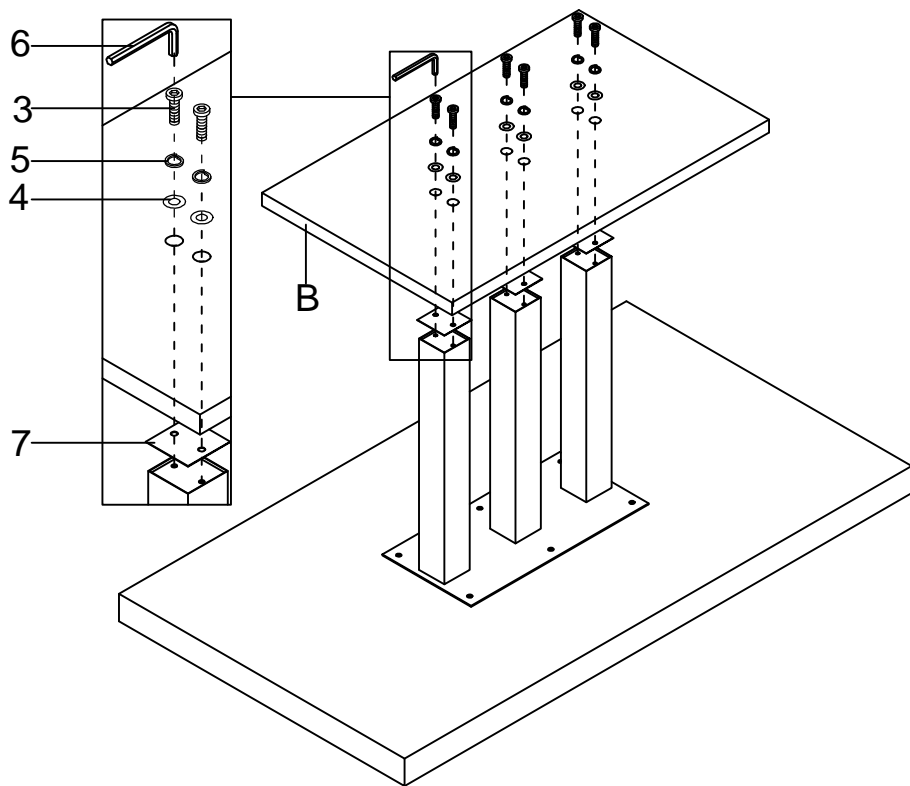

COASTERFURNITURE.COM

ITEM:193811



# ASSEMBLY INSTRUCTIONS

## STEP 5

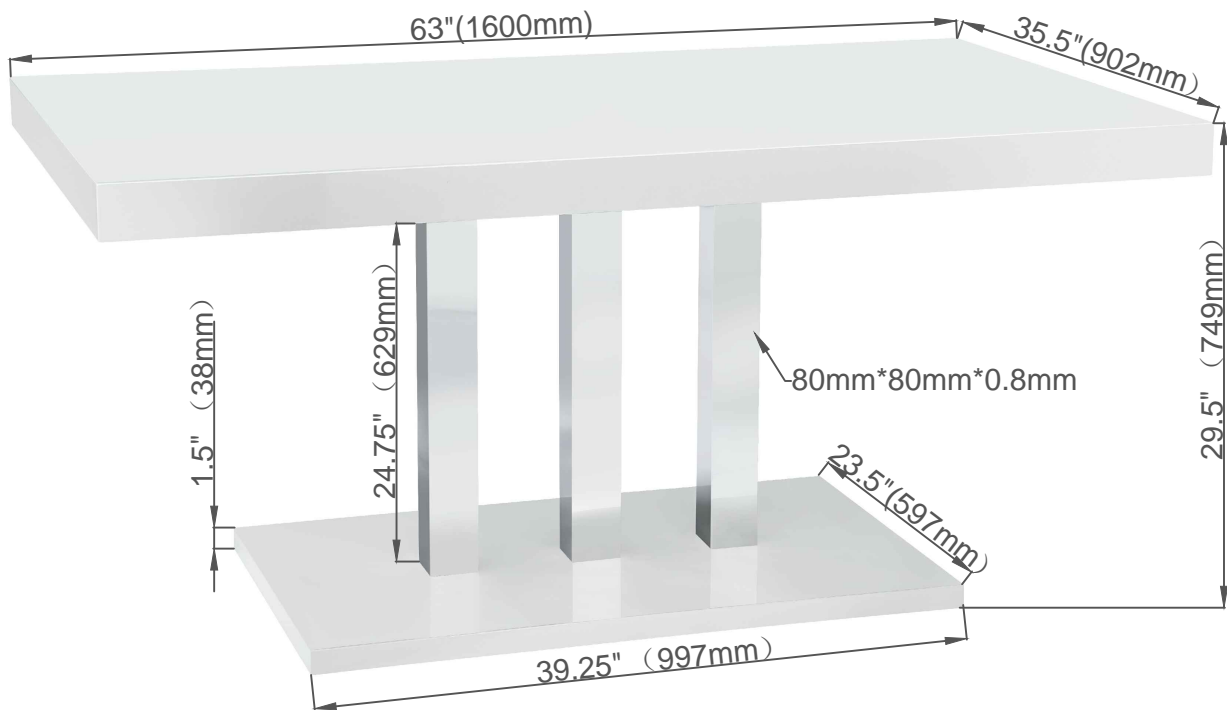
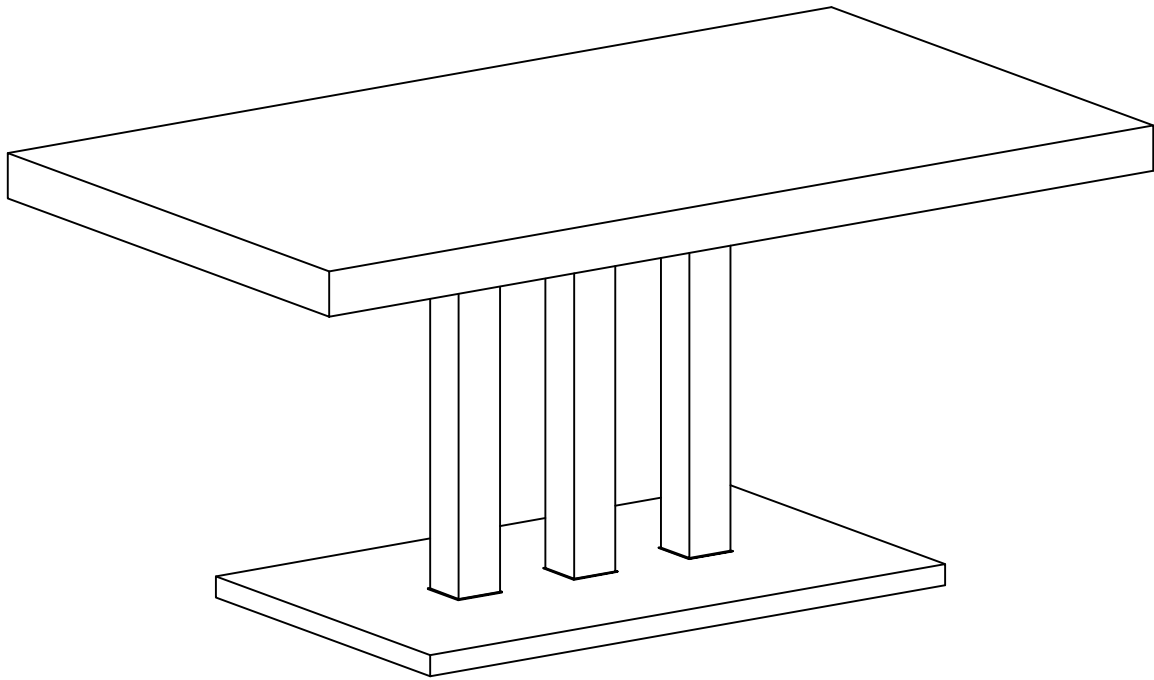

COASTERFURNITURE.COM