

*ASSEMBLY INSTRUCTIONS*  
*COASTER FINE FURNITURE*

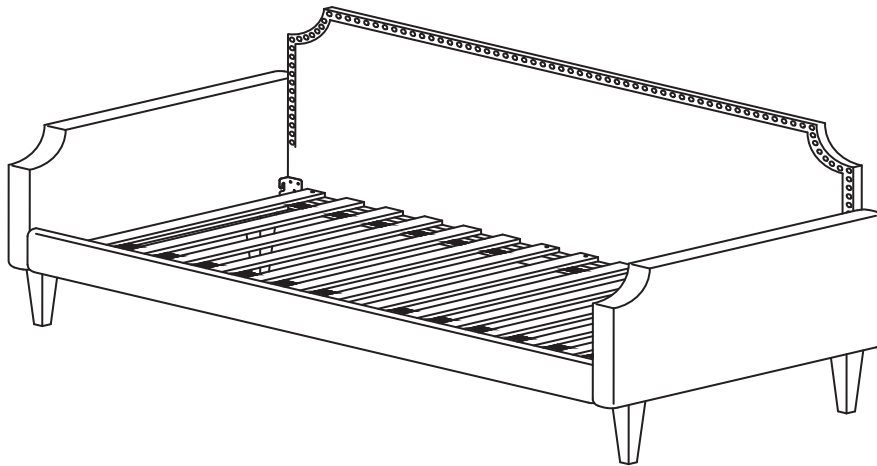

*Fine Furniture for every stage of life*

**300636**  
***Daybed***

ITEM: **300636**



## ASSEMBLY INSTRUCTIONS

### ASSEMBLY TIPS:

1. Remove hardware from box and sort by size.
2. Please check to see that all hardware and parts are present prior to start of assembly.
3. Please follow attached instructions in the same sequence as numbered to assure fast & easy assembly.



### WARNING!

1. Don't attempt to repair or modify parts that are broken or defective. Please contact the store immediately.
2. This product is for home use only and not intended for commercial establishments.



ASSEMBLY TIME

35 MINUTES

## PARTS IDENTIFICATION

A	BACK PANEL		1PC	D	FRONT RAIL		1PC
B	LEFT SIDE PANEL		1PC	E	LEG		4PCS
C	RIGHT SIDE PANEL		1PC	F	ROLL SLAT (7PCS)		2SETS

## HARDWARE IDENTIFICATION

1	SHORT BOLT (M8 x 20MM - RBW)		8PCS	5	FLAT WASHER (15/64" x 19 Ø - RBW)		2PCS
2	MEDIUM BOLT (M6 x 25MM - RBW)		8PCS	6	FLAT HEAD SCREW (M4 x 32MM - RBW)		8PCS
3	LONG BOLT (M6 x 50MM - RBW)		2PCS	7	SMALL ALLEN WRENCH (M4 x 65MM - BLK)		1PC
4	LOCK WASHER (15/64" x 12 Ø - RBW)		10PCS	8	BIG ALLEN WRENCH (M5 x 65MM - BLK)		1PC

### NOTE:

Phillips head screw driver is required in the assembly process; however, manufacturer does not provided this item.

ITEM: **300636**

**ASSEMBLY INSTRUCTIONS**

**STEP 1**

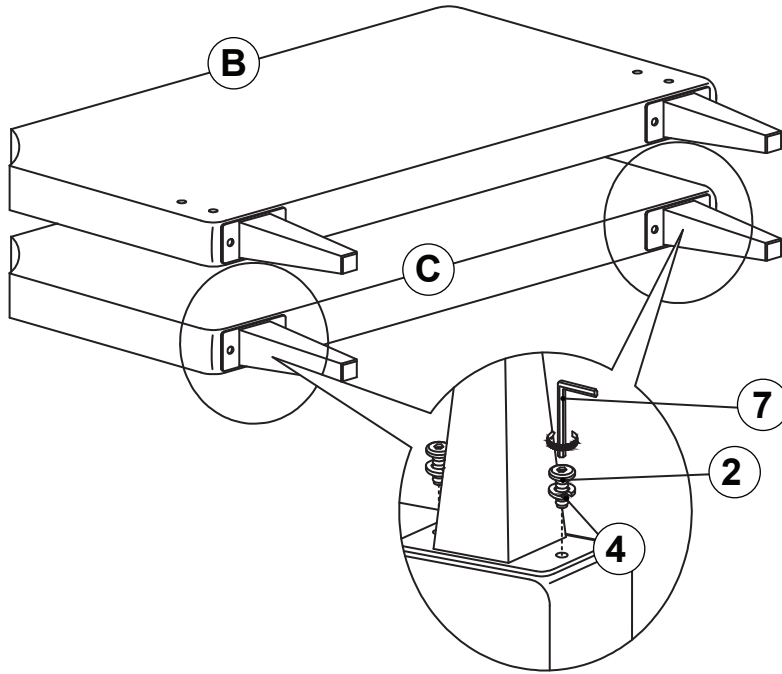

**STEP 2**

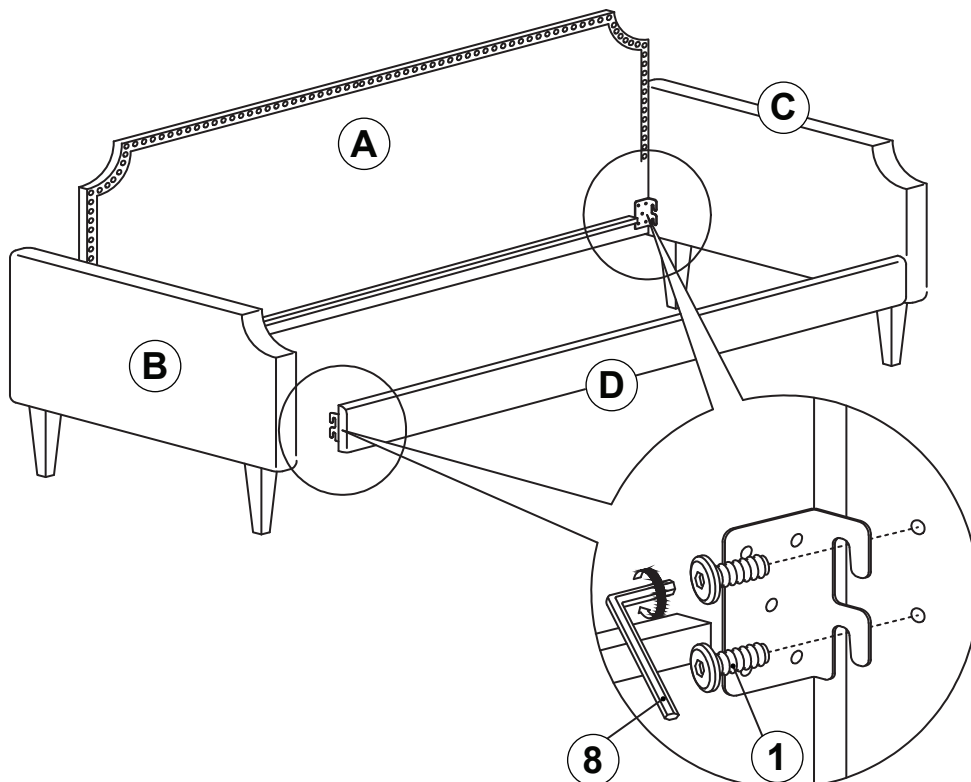

ITEM: **300636**

**ASSEMBLY INSTRUCTIONS**

**STEP 3**

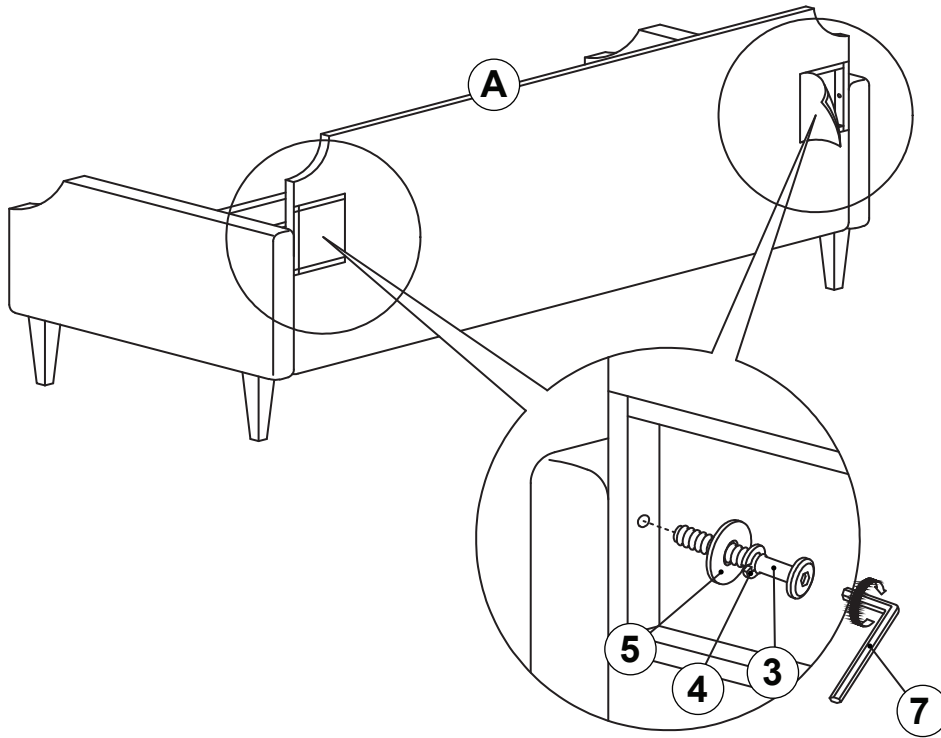

**STEP 4**

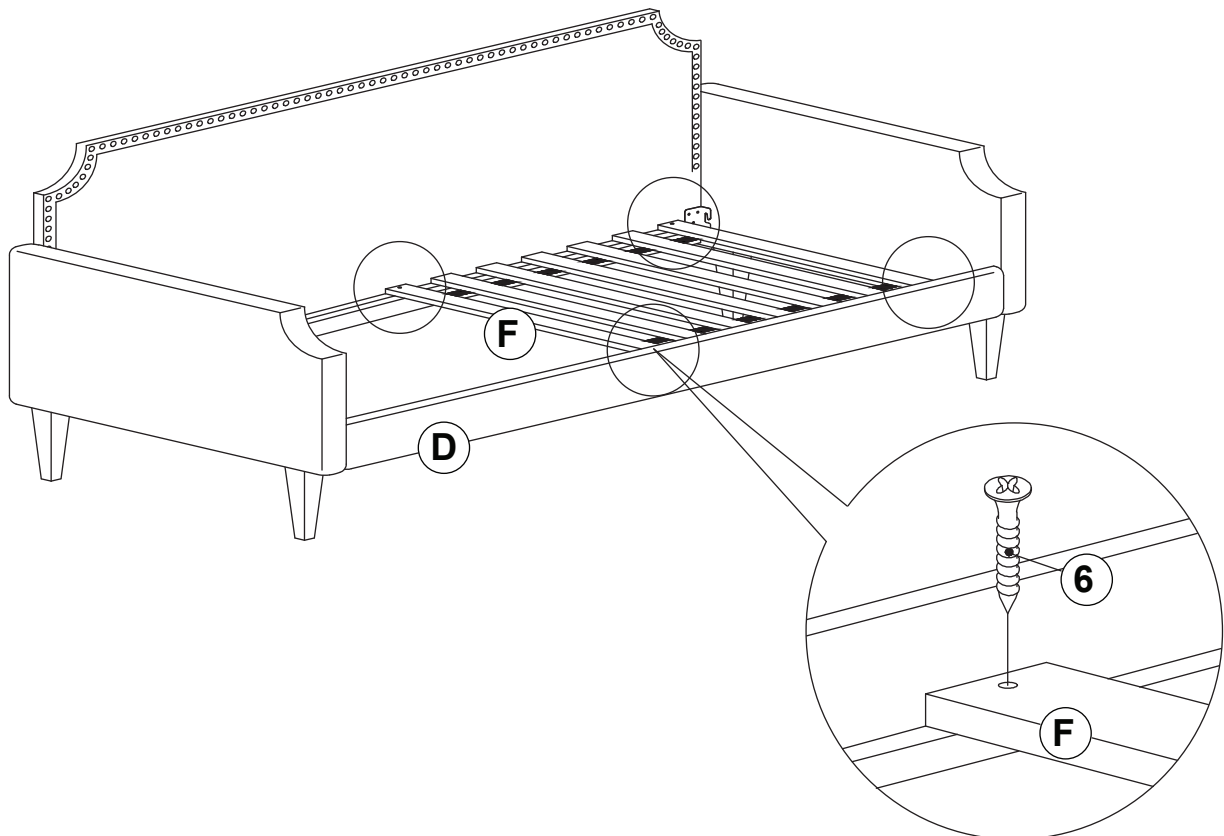

ITEM: **300636**



**ASSEMBLY INSTRUCTIONS**

**STEP 5**

**COMPLETE**

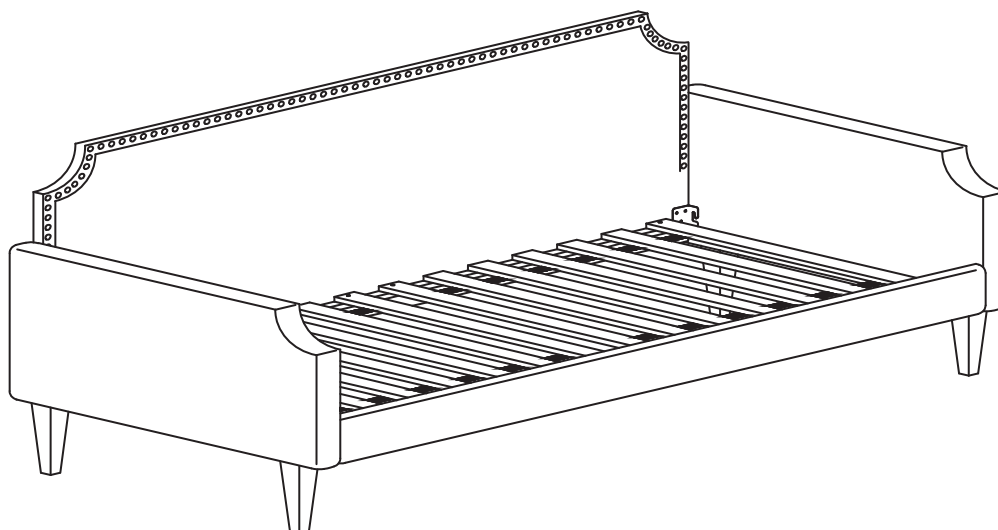

ITEM: **300636**



INNER SIZE : 39.57" X 76.18"

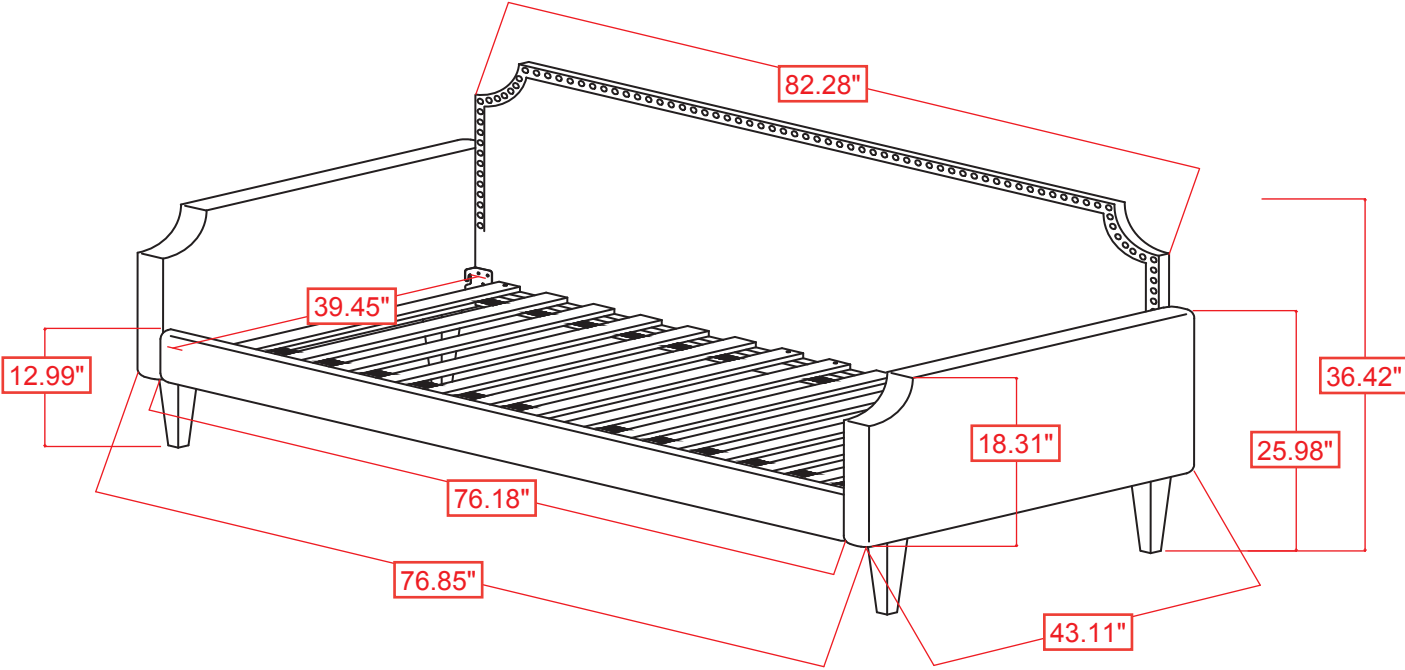

Note : Dimension tolerance  $\pm 5\%$