



SEMI BAFFLE
FILTER



LED LIGHT

EXCLUSIVE
PLUS FEATURES

This model, with its pyramid shaped angles and stainless steel finish, makes a striking visual statement to any kitchen. Available in 30" or 36" widths, features Black panel touch controls, LED lighting and 3-speed blower. It also features a telescopic chimney for up to 9'1" ceilings.

Designed for standard ducted installation it can also be installed as a recirculating system using the kit available as an accessory.

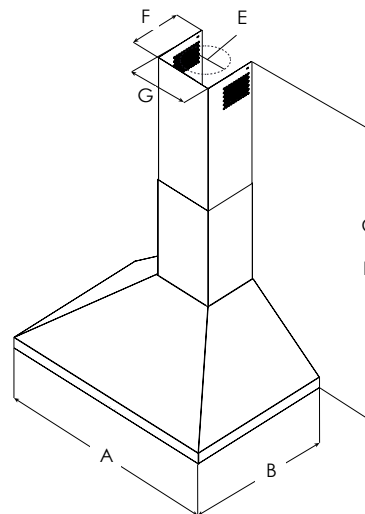

*Ductless version
(Recirculating)
**Ducted version



	PCHBL630SS	PCHBL636SS
A	30" (76.2 cm)	36" (91.4 cm)
B	19 1/16" (50 cm)	
C*	Max: 42 1/8" (107 cm) Min: 28 3/8" (72 cm)	
D**	Max: 38 3/16" (97 cm) Min: 28 3/8" (72 cm)	
E	6" (15.24 cm)	
F	7 3/16" (18.3 cm)	
G	8 3/16" (20.8 cm)	

SPECIFICATIONS

Widths:	30" Unit	36" Unit
Model:	PCHBL630SS	PCHBL636SS
Dimensions:	30"Wx 19 11/16"D x Min:28 3/4" Max: 41 1/8 "H	36"Wx 19 11/16"D x Min:28 3/4" Max: 41 1/8 "H
Blower Type(internal):	600 CFM(4-speed)	
Blower Performance:**	Min: 100, Max: 600 CFM Min: 1, Max: 6.8	
Power (CFM):		
Noise (sones):		
CFM Reduction:	Electronic CFM reduction KIT included	
Finish:	Stainless Steel	
Controls:	Black Panel Touch Control	
Illumination:	2 LED Lights, 2.1 Watts, 4000 Kelvin, 180 lumens/lamp	
Grease Filter:	Dishwasher-Safe, Stainless Steel Baffle Slot Filters 2 with 30" & 3 with 36"	
Duct Transition:	6" Round with BackDraft Damper (top only)	
Installation Type:	Ducted, Recirculating Kit sold separately	
Electrical:	120V - 60 Hz, 265 watts	
KITS:		
Long Chimney Extension Kit:	ACC02762	
Recirculating Kit:	ACC02766	
INSTALL HEIGHTS:		
Ranger Hood:	Ducted: Min: 7'5", Max 9'1" Recirculating: Min: 7'5", Max: 9'6"	
Ranger Hood with extension duct covers:	Ducted: Min: 8'5", Max 11'3" Recirculating: Min: 8'6", Max: 11'7"	
WARRANTY:	One (1) year parts & in-home labor	

PLUS FEATURES



STAINLESS STEEL BAFFLE SLOT FILTERS - A baffle shaped stainless steel filter with mesh backing allows air to pass but blocks grease, which drops into the high capacity baffle cavities. The design delivers large volume capacity, excellent capture efficiency at ALL blower speeds, silent operation, plus, durability that will last the life of the hood.



LED LIGHT - LED lighting is undoubtedly the smartest solution in terms of energy saving. Expected life time of over 20,000 hours, represents the most remarkable advantage of LED light bulbs.



HUSH SYSTEM - An exclusive sound deadening technology that effectively reduces sound levels by over 35%

HVI Certified Ratings	High Speed	Working Speed	Duct Size
CFM	330	140	6" (Vertical)
Sones	5.5	0.5	6" (Vertical)

* The product images shown are for illustration purposes only and may not be an exact representation of the product.

** Blower performance indicates the performance of the blower by itself. Performance claims are not HVI certified but were established in accordance with HVI Standardized test procedure. For Certified Ratings, please refer to HVI Certified Product Directory. Electric Ratings are declared according to UL.