



AGA CITY24

(Gas Top Burners)

Users Instruction

CAUTION: THIS UNIT IS HEAVY, PROPER EQUIPMENT AND ADEQUATE MANPOWER MUST BE USED IN MOVING THE RANGE TO AVOID DAMAGE TO THE UNIT OR THE FLOOR.

REMEMBER, when replacing a part on this appliance, use only spare parts that you can be assured conform to the safety and performance specification that we require.

DO NOT use reconditioned or copy parts that have not been clearly authorised by AGA.

**PLEASE READ THESE INSTRUCTIONS BEFORE USING THIS APPLIANCE
AND KEEP IN A SAFE PLACE FOR FUTURE REFERENCE.**

My AGA Details

AGA City24 (Gas Top Burners)

Serial No _____

AGA Service No _____





Date of Installation _____

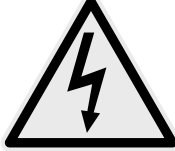

Contents

My AGA Details	2
PRODUCT SAFETY	4
IMPORTANT SAFETY INSTRUCTIONS	5
Introduction	6
A Brief Description - AGA City24 (Gas Top)	7
Equipment supplied with your AGA City24 (Gas Top)	8
How To Use Your AGA City24 <i>(Gas Top)</i>	9
Range Hoods and Oven Venting	10
General Advice	10
Using the Zones of the AGA City24	10
The Gas Top Burners	11
Cast Iron Grates	12
Assembly of Burners	12
The Ovens	13
Hints and Tips for using the AGA City24 (Gas Top)	18
Caring and Cleaning	21

PRODUCT SAFETY

MEANING/DESCRIPTION	SYMBOL	SIGNIFICATION/DESCRIPTION
<p>WARNING/CAUTION</p> <p>An appropriate safety instruction should be followed or caution to a potential hazard exists.</p>		<p>AVERTISSEMENT</p> <p>Une consigne de sécurité appropriée doivent être suivies ou garde d'un danger potentiel exists.</p>
<p>DANGEROUS VOLTAGE</p> <p>To indicate hazards arising from dangerous voltages.</p>		<p>TENSION DANGEREUSE</p> <p>Pour indiquer les dangers résultant des tensions dangereuses.</p>
<p>PROTECTIVE EARTH (GROUND)</p> <p>To identify any terminal which is intended for connection to an external conductor for protection against electric shock in case of a fault, or the terminal of a protective earth (ground) electrode.</p>		<p>TERRE DE PROTECTION</p> <p>Pour marquer bornes destinées à être raccordées à un conducteur de protection extérieur contre les chocs électiques en cas de défaut d'isolement, ou pour marquer la borne de la terre de protection.</p>
<p>HEAVY</p> <p>This product is heavy and reference should be made to the safety instructions for provisions of lifting and moving.</p>		<p>LOURD</p> <p>Ce produit est lourd et doit être fait référence aux consignes de sécurité relatives aux dispositions de soulever et déplacer.</p>
<p>DISCONNECT MAINS SUPPLY</p> <p>Disconnect incoming supply before inspection or maintenance.</p>		<p>APPAREIL À LASER DE CLASSE 2</p> <p>Alimentation d'entrée Débrancher avant inspection ou d'entretien.</p>
<p>REFER TO MANUAL</p> <p>Refer to relevant instructions detailed within the product manual.</p>		<p>ATTENTION, SURFACE TRÈS CHAUDE</p> <p>Reportez-vous aux instructions applicables, indiquées dans le manuel du produit.</p>

IMPORTANT SAFETY INSTRUCTIONS



INCORRECT USE OF THIS RANGE CAN INCREASE THE RISK OF FIRE, ELECTRIC SHOCKS OR INJURY TO PERSONS.

PLEASE READ THE FOLLOWING PRECAUTIONS TO REDUCE THESE RISKS.

This appliance is not intended for use by persons (including children) with reduced physical, sensory or mental capabilities, or lack of experience and knowledge, unless they have been given supervision or instruction concerning use of the appliance by a person responsible for their safety.



ALWAYS

Always make sure children are never left alone or unsupervised when the range is on.

Always be aware that range surfaces will be hot during and after use and can cause burns.

Always teach children that the range and utensils can be hot.

Always allow heavy and hot utensils to cool in a safe place and out of reach of small children.

Always be aware hot grease is flammable. Wipe off any grease deposits on the range top and front.

In the event of a grease fire, do not remove the pan, cover the pan to extinguish the flame.

Always turn utensil handles inwards but not cover adjacent heated surfaces, to prevent accidental spillage and burns.

Always when opening an oven door, allow hot air and steam to escape.

Always use dry pot holders. Moist pot holder will cause steam burns. Do not use towels or other cloths near the heated plates.

Always clean ventilation hoods frequently. grease should not be allowed to accumulate in hood and filters.

Always make sure cabinet and work surface are capable of supporting heavy cooking utensils used on your range.

Always make sure cooking utensils are suitable for range top service. Only certain types of glass, glass ceramic earthenware/glazed utensils with stand sudden temperature changes without breaking.

Always make sure your appliance is properly installed and grounded by a qualified technician.

Always make sure your appliance is serviced by a qualified technician.



NEVER

Never use this appliance as a space heater to heat or warm the room. Doing so may result in carbon monoxide poisoning and overheating of the room.

Never store items of interest to children above the range.

Never allow children to climb on, sit or stand on any part of the range.

Never allow children to play with the controls or any part of the range.

Never wear loose fitting clothing or other flammable materials that could contact hot surfaces on the range.

Never leave boiling pans unattended, boil over causes smoking and greasy spillovers may ignite.

Never store gasoline or other volatile liquids in the range or in cabinets above or near the range, which can catch fire or explode.

Never use water on grease fires. Smother fire or flame or use a dry chemical or foam type extinguisher.

Never repair or replace any part of the appliance unless recommended in this manual. All other servicing should be carried out by a qualified technician.

Never cover or restrict the air flow to the controls compartment.

Never install cabinets (shelves) or similar above the range with a depth greater than 13" (330mm).

Never heat unopened food containers. Pressure build-up may cause the container to burst and cause injury.

Never reach directly into a hot oven to add or remove cooking utensils. Instead pull the grid shelf out to its maximum projection.

Never use a steam cleaner to clean your range.

Never use caustic cleaners, abrasive pads or metal scrapers to clean enamel surfaces.

Introduction

Welcome to the world of AGA. Your AGA City24 is a compact range which combines the design values and cooking principles of the traditional AGA with the flexibility to turn each cooking area off and on as you require, thereby fitting into your lifestyle beautifully.

Your range has a gas top and two electric cast iron ovens.

Your AGA City24 has been made in the heart of Shropshire in England, as AGA ranges have been for generations, from cast iron manufactured at the Coalbrookdale Foundry. The traditional skills of iron making have been united with industrial strength electric elements to enable the ovens to reach cooking heat within a relatively short time, with one or both ovens, as your cooking requires.

The AGA has been famous since its inception in the 1920s for its cooking excellence, made possible by heat stored in the cast iron. This indirect radiant heat means food retains its natural flavour and succulence as it is cooked from the heat stored in the castings, rather than relying on air temperature.

Your AGA City24 has been designed to have all the attributes of a larger AGA within a small space.

A Brief Description - AGA City24 (Gas Top)

4 Burner Gas Top

Top Oven (Roasting Oven and Baking Oven setting)

Slow Cook Oven



The AGA City24 Gas Top has the iconic cast iron ovens with the flexibility of four gas top burners.

As the AGA works on the principle of storing heat, time is required to gather that heat from the electric elements to saturate the castings. We recommend to allow an hour heat up time for the best cooking performance.

The principle of heat storage means that the ovens are at a pre-set heat, the cooking ovens are named after their function rather than temperatures (which are governed by measuring hot air not stored heat). All levels of heat are catered for - high, moderate and low.

See "How To Use Your AGA City24 (Gas Top)" page 8 for gas top burner oven symbols and brief description.

Gas Top



Top Oven (Roasting Oven Setting)

The hottest oven setting for high temperature cooking; pastries, breads, roasting of meat, vegetables and poultry, broiling at the top of the oven and frying on the floor grid on the base of the oven. The ovens are vented into the room, so some cooking smells will be present.

See **"Range Hoods and Oven Venting"** page 9 for information on range hoods and oven venting.

Top Oven (Baking Oven Setting)

A moderate oven setting for cooking cakes and biscuits, baking fish, lasagne or shepherd's pie, plus roasting meat and poultry at a medium heat. Cooking sweet and savoury together is no problem as the flavours do not mix.

Slow Cook Oven

Long, slow cooking in the slow cook oven develops flavors and makes the toughest meat tender. It's large capacity means several pans can be stacked here; soup, casserole, steamed rice, steamed carrots and poached pears all cooking simultaneously, without any danger of burning.

Equipment supplied with your AGA City24 (Gas Top)



Large Size Roasting Pan with Broiling Rack

This is designed to slide onto the oven runners without the need for it to sit on an oven grid shelf. The roasting pan can be used with the broiling rack, in its high position, for broiling at the top of the roasting oven. It can be used for roasting meat, or poultry with or without the broiling rack. Large quantities of roast potatoes can be cooked in this pan. The roasting pan can also be employed for making large sponges or cakes. The broiling rack is useful on its own as a cake cooling rack. Can be used in any oven but not recommended for gas top use.



Half Size Roasting Pan and Broiling Rack

This pan can be slid onto the oven runners width-ways or can sit on an oven grid shelf. The half size roasting pan can be used with the broiling rack, in its high position, for broiling at the top of the roasting oven. It can be used for roasting smaller joints of meat, or poultry with or without the broiling rack. Roast potatoes can be cooked in this pan. The roasting pan can also be employed for making sponges or cakes. The broiling rack is useful on its own as a cake cooling rack. Can be used in any oven but not recommended for gas top use.

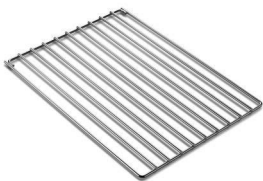

2 Floor Grids

These grids are used on the base of the ovens, to protect food from the heat of the base element.

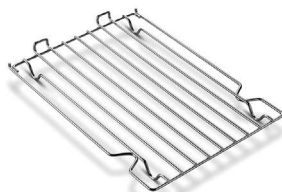

2 Oven Grid Shelves

These are for inserting in each oven to provide a surface for dishes and tins which do not fit directly onto the oven runners. They can be used in any oven, as required. See page 20 on how to locate the oven shelves correctly.



1 Cold Plain Shelf

This has two uses one as a large baking sheet for scones, biscuits, pastry items and meringues and the other use as a heat deflector to cut off the top heat if food is overbrowning before it is cooked through.

DO NOT STORE in the ovens when not in use.



Wire Brush

This is for cleaning the raw cast iron surfaces, keeping them clear of crumbs and burnt on debris – which would otherwise affect the performance. Use in the ovens, take care not to touch the enamel surfaces as the wire brush will scratch the finish.



AGA Utensils and Accessories

To get the very best performance from your range AGA saucepans are recommended with the thick

tri-core bases and stacking lids so that the maximum use of oven space is made and an AGA kettle for boiling water. AGA Accessories can be viewed at local AGA dealer or online at www.aga-ranges.com.

Getting to know your AGA

If you have not already seen a live AGA demonstration, ask AGA Kitchen Concierge for details 800-525-5601. A demonstration will show to get the best from your new AGA range plus learn hints and tips. You will also see a selection of AGA utensils and accessories being used. RSVP for a demonstration online at www.aga-ranges.com.

How To Use Your AGA City24 *(Gas Top)*

Getting started

When switching on the AGA range for the first few times, there are two things you may notice, neither of which should cause concern.

The AGA range will emit an odour for a short while, this is simply due to the protective oil we put in the ovens, burning off. Due to the newness in the first couple of hours, it is advisable to open the kitchen window while this takes place.

Condensation may occur on the top and front plate whilst the AGA range is heating up. Any condensation should be wiped away as soon as possible to prevent staining the enamel.



Gas Top

The gas top control knobs can only be rotated anti-clockwise from the OFF position. See **“The Gas Top Burners” page 10**



OFF



(Large Flame) - High Setting



(Small Flame) - Low Setting

Ovens



OFF - The oven control knob can be rotated either clockwise or anti-clockwise from the OFF position. See oven section, **“The Ovens” page 12.**



Top Oven - Baking Oven Setting ON



Slow Cook Oven OFF



Top Oven - Baking Oven Setting ON



Slow Cook Oven ON



Top Oven - OFF



Slow Cook Oven - ON



Top Oven - Roasting Oven Setting ON



Slow Cook Oven - ON



Top Oven - Roasting Oven Setting ON



Slow Cook Oven - OFF

PLEASE NOTE: Gas top and oven controls on this appliance are ‘push to turn’ operation.

Range Hoods and Oven Venting

The use of a gas cooking range results in the production of heat and moisture in the room in which it is installed. Ensure that the kitchen is well ventilated, keep the natural ventilation holes open or install a range hood.

It is recommended that this AGA is fitted with a range hood above it. The AGA venting system is located on top of the AGA and is designed for venting the moisture from the ovens. The range hood should be positioned not less than the minimum height as recommended by the manufacturer, from the top of the AGA.

The AGA City24 ovens are manufactured from cast iron, over a period of time they will become individually seasoned. However, the ovens will rust if high moisture content foods are not covered (especially in the slow cook oven) or spillages are not cleaned up.

It is also not advisable to leave a full or partially filled saucepan/utensils with high moisture content food in the ovens when they are not in use.

To season the ovens a light vegetable oil is ideal (corn oil is best). A spray oil is recommended. Any stubborn stains can be removed with the wire brush supplied.

Please refer to "**Caring and Cleaning**" page 20, for Cleaning of Ovens.

General Advice

Food **SHOULD NOT** be placed into any oven until the oven is up to normal operating heat.

The oven doors should not be left open for long periods of time during cooking and heating up.

Store the cold plain shelf outside the range. Use it cold in the roasting oven to deflect heat from the top of the oven, creating a more moderate oven temperature underneath. It can also be used as a baking sheet.

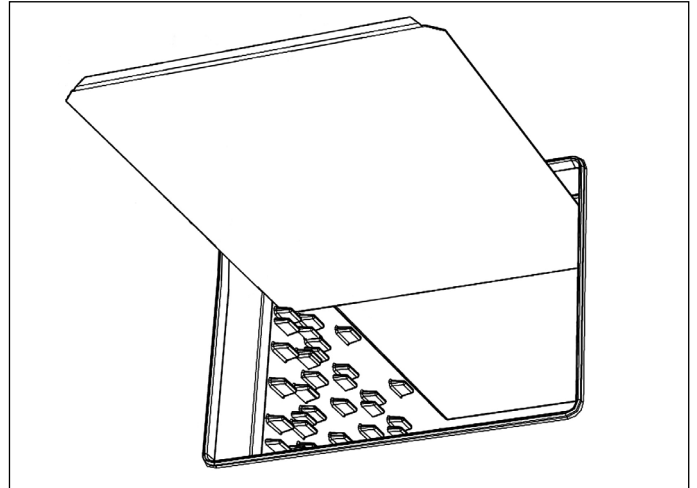

Warm up times

As the AGA works on the principle of storing heat, time is required to gather that heat from the electric elements to saturate the castings. **We recommend to allow an hour heat up time.**

The principle of heat storage means that the ovens are at a pre-set heat, the cooking areas are named after their function rather than temperatures.

Using the Zones of the AGA City24

The different zones of the AGA City24 range are described individually, in the following pages.

The traditional AGA heat storage range is famous for the gentle warmth it emits, with the AGA City24 you will get warmth only when the cooker is on or warmth to a lesser degree when only parts of it are on.

The Gas Top Burners

The hob has four gas burners:

- **front left** - ultra rapid (wok) burner - rated at 12,000 Btu's
- **rear left** - semi-rapid burner - rated at 6,150 Btu's
- **rear right** - rapid burner - rated at 10,600 Btu's
- **front right** - semi-rapid burner - rated at 6,150 Btu's

The semi-rapid burner is especially suited for use with small pans and gentle simmering or poaching.

All burners have a set simmer position and are easily adjustable.

TO USE THE HOB

To light a hob burner: push in and turn the control knob anti-clockwise to the large flame symbol, and hold in for 3 seconds until the burner lights, then turn the knob to the required setting.

If the burner flame should accidentally go out, turn off the burner control and do not attempt to re-light the burner for at least one minute.

The control may be set towards a lower position, simply by turning the control knob towards the small flame symbol.

IMPORTANT: The cast iron pan grates on the appliance are much heavier than those on most gas top ranges, therefore care must be taken when removing or re-fitting them to the gas top. It is important that they are lifted from the appliance and not dragged across nearby enamelled parts which would result in damaging the enamel.

SOME SAFETY POINTS

- Simmering aids such as mesh mats are not recommended. They can impede burner performance, damage the pan supports and waste fuel.
- Commercially available foil spillage aids are unnecessary on this cooker and could effect the combustion.
- Some 'wok' cooking pans are unstable. Check with the 'wok' manufacturer before purchasing.
- **DO NOT** use unstable and mis-shapen pans (e.g. with convex bases) that tilt easily.
- Pans and kettles with concave bases should not be used.
- The minimum pan diameter recommended is 5" (12cm), maximum recommended pan diameter is 11" (28cm).
- Place all pans centrally over the burners. The flames must be on the base of the pan. **DO NOT** allow the flames to go up the sides of the pan. (See **Fig. 1.1**).
- Always position pan handles away from the front of the range - out of reach of small children.
- **NEVER** leave a chip pan unattended.

NOTE

Aluminium pans may cause a metallic marking on the pan supports. This will not affect the durability of the enamel. The appliance warranty does not cover mis-use of the pan supports.

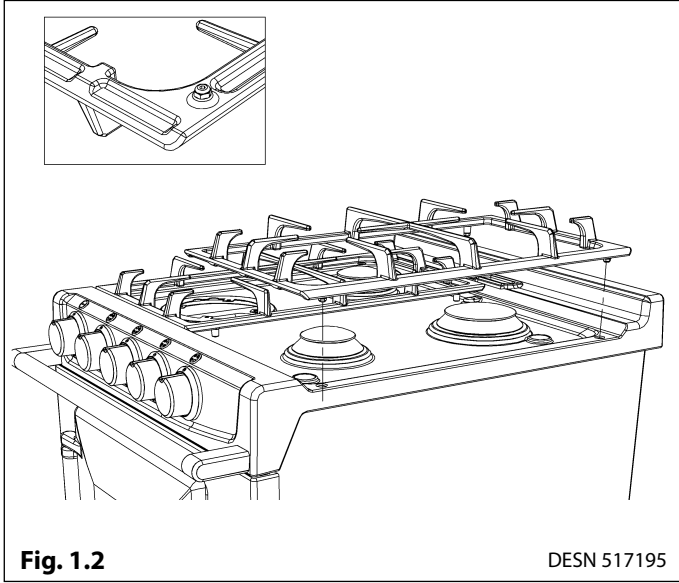

Fig. 1.1

DESN 512396

Cast Iron Grates

It is important for performance and reliability that the pan supports are fitted correctly. They must locate in the recesses in the gas top casting. (See **Fig. 1.2**).



FITTING OF BURNER CAP (RAPID AND SEMI-RAPID)

PLACE BURNER CAP OVER RETAINING LUGS, THEN TURN CAP CLOCKWISE TO LOCK INTO POSITION.

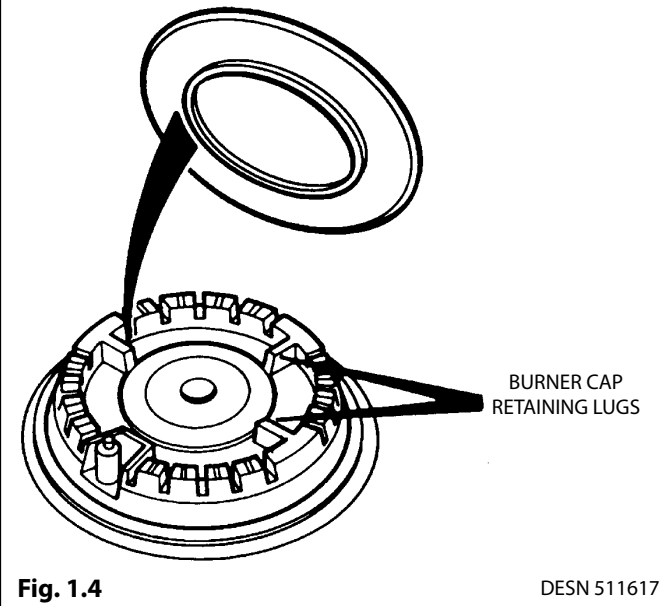

Assembly of Burners

ASSEMBLY OF RAPID AND SEMI-RAPID BURNER

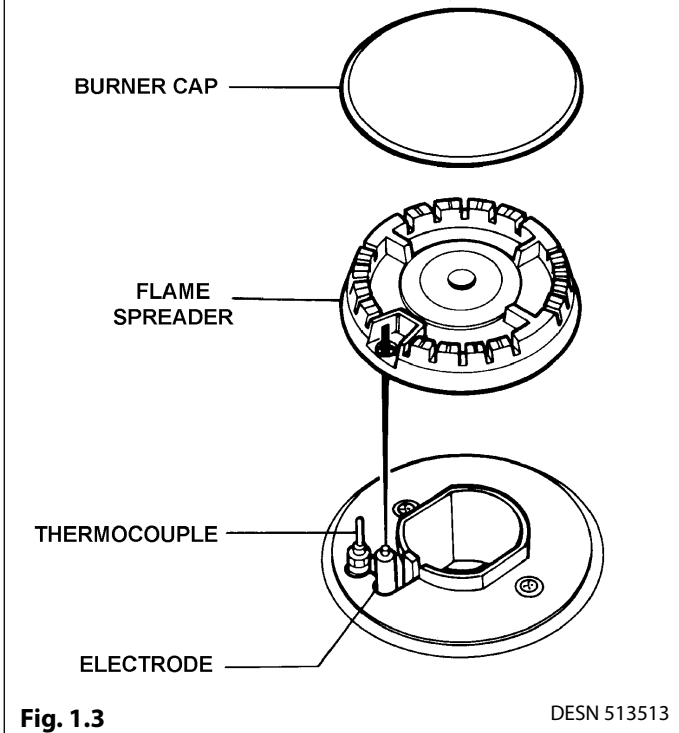

WOK BURNER

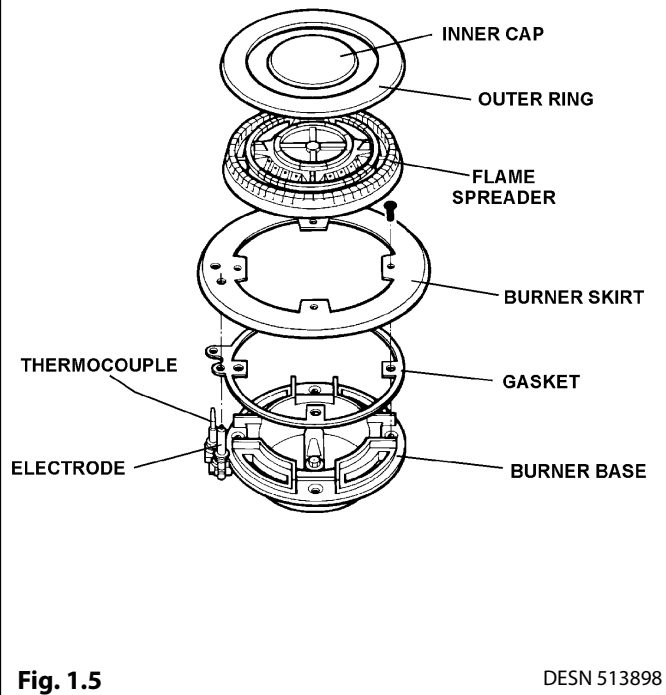

The Ovens

Your AGA City24 has two ovens which are pre-set at a different heat, just like the traditional AGA heat storage range. The top oven has two heat settings one for the roasting and one for baking.

Top Oven

The Roasting Oven Setting for high temperature cooking

The Baking Oven Setting for moderate temperature cooking

The Slow Cook Oven for long, slow cooking.

The ovens are made from cast iron, which cooks by a radiant heat and this is the secret of the cooking excellence for which the AGA range is renowned. An indirect radiant heat does not dry food out, so it retains its natural moisture and flavour.

You can have one or two ovens on at their pre-set heat.

Each oven has the same capacity, (able to fit a 28lb (13kg) turkey) and the traditional AGA heat-storage range techniques can be used, such as stacking saucepans in the slow cook oven. This enables the steaming of root vegetables, rice and steamed pudding; casseroles meat and poaching fruit all in the same oven leaving the gas hob free.

DO NOT OPERATE THIS APPLIANCE WITH THE DOORS OPEN, SINCE THIS CAN CAUSE THE CONTROL KNOBS TO GET HOT.

The Roasting Oven Setting



See page 9 for oven symbols and brief description.

This top oven is heated by two elements, one in the base of the oven and the other in the roof. These elements heat the air and the cast iron within to provide cooking results consistent with the traditional AGA heat-storage range, with the flexibility of being able to turn it off when not in use.

For the best cooking performance, please allow at least one hour for the cast iron to become saturated in heat.

The roasting oven setting can be used for 'broiling' at the top and 'shallow frying' on the oven floor.

When cooking on the base of the roasting oven, make sure the floor grid is on the floor before putting the food into the oven. This lifts the food away from the base element to ensure the best cooking results are achieved.

The roasting oven setting is zoned in heat, meaning it is slightly hotter towards the top than the center and the oven grid shelf set on the oven floor is slightly less hot than the center.

The roasting oven is very hot, wonderful for cooking meat and poultry, roast potatoes and other vegetables, crispy jacket potatoes, grilled foods, pastry items and bread.

The top of the oven, second runners down is great for grilled breakfasts and browning dishes such as gratins. Whereas the middle of the oven is best for roast meats and scones. Tarts, quiches and bread are better near the floor of the oven.

The base of the oven can be used as another cooking surface, indeed it is often called a hidden hotplate always use the floor grid for protection so food does not overbrown.

The beauty of the roasting oven setting is that any fat is burnt off when the oven is at full heat, just brush out occasionally to remove the carbon deposits.

The roasting oven setting is excellent for bread and pastries. Quiches in ceramic or pies in Pyrex dishes need not be baked blind as when they are in placed on the floor grid on the base of the oven the pastry cooks from underneath and the filling will set and brown from the all-round heat. As you are aware metal flat tins conduct heat quicker than ceramic and may need less cooking time.

The specially designed roasting pans and bakeware slide directly onto the runners, so almost every available square inch of space can be used. Food can be protected by the use of the cold plain shelf or shielded by means of the large roasting pan which means you can cook food that requires different temperatures at the same time. If food is browning too quickly and you do not want to move it to another oven just slide the cold plain shelf over the food to reduce the top heat.

The Baking Oven Setting



See page 9 for oven symbols and brief description.

The top oven is heated by two elements, one in the base of the oven and the other in the roof. These elements heat the air and the cast iron within to provide cooking results consistent with traditional AGA heat storage range, with the flexibility of being able to turn it off when not in use.

This setting is a moderate heat, so is ideal for cakes, biscuits, also anything that requires medium heat cooking such as fish pie, lasagne, soufflés, crumble and roulades. Meat and poultry can be cooked here indeed most things that can be cooked on the roasting oven setting can be cooked on the baking oven setting but for a longer time.

For the best results when cooking cakes do allow at least the one hour heat up time. Cook cakes together on one shelf. If two shelves are used interchange the food to achieve even coloration, as you would with any oven which is zoned heat.

As with the roasting oven setting, the specially designed roasting pans and bakeware slide directly onto the runners, so almost every available square inch of space can be used. Food can be protected by the use of the cold plain shelf or shielded by means of the large roasting pan, which means that you can cook food that requires different temperatures at the same time. If food is browning too quickly and you do not want to move it to another oven just slide the cold plain shelf over the food to reduce the heat.

NOTE: If you have a choice it is better to get the baking items cooked first then turn the oven to the roasting oven setting, as the ovens can take up to 3 hours to move from roasting down to a baking heat.

NOTE: Always remove the cold plain shelf and roasting pans on completion of cooking, if left in the oven it will affect the oven temperature.

The Slow Cook Oven



See page 9 for oven symbols and brief description.

The slow cook oven is indirectly heated by one element in the base of the oven.

This element heats the air and the cast iron within it to provide cooking results consistent with the traditional slow cook oven of the traditional AGA heat-storage range, with the flexibility of being able to turn it off when not required.

The floor grid is used here to protect items placed on the base of the oven such as vegetables for steaming, keeping sauces warm or casseroles cooked for a long time. Always ensure this is in place, before putting food into the oven.

The slow cook oven can be described as a continuation oven, it continues to cook food that has been brought up to heat elsewhere on the range with the exception of meringues which are dried out rather than 'cooked'.

The Slow Cook Oven

User Guidance

- Allow the oven to heat fully, the longer the oven is on the better, we recommend one hour.
- To get the very best performance, we recommend to use AGA cookware with thick bases and stacking lids.
- **DO NOT** place dishes directly on to the oven base. Always place onto either a shelf or the floor grid.
- If slow cooking joints of meat these should be brought up to heat ideally on the roasting oven setting and then transferred to the slow cook oven.(This method is unsuitable for stuffed meat and stuffed poultry).
- Make sure that pork and poultry reach an internal temperature of at least 167°F (75°C).
- Always bring soups, casseroles and liquids to the boil before putting in the slow cook oven.
- Always thaw frozen food completely before cooking.
- Root vegetables will cook better if cut into small pieces.
- Adjust seasoning and thickenings at the end of the cooking time.
- Many dried beans for example, dried red kidney beans must be boiled for a minimum of 10 minutes, after soaking, and before inclusion in any dish.

Below is a quick guide to oven usage

AGA OVENS

ROASTING OVEN SETTING

- Grilling
- Scones
- Pastries
- Bread
- Yorkshire puddings
- Roasts
- Shallow frying

BAKING OVEN SETTING

- Cakes
- Biscuits
- Fish
- Shepherds pie, Cottage pie
- Lasagne
- Soufflés
- Shortbread

SLOW COOK OVEN

- Casseroles
- Stock
- Milk puddings
- Meringues
- Rich fruit cake

OVEN TEMPERATURE

HIGH

- Top - broiling
- 2nd runner - scones, small pastries, broiling
- 3rd runner - bread rolls , Yorkshire pudding
- 4th runner - roasts, poultry
- Oven grid shelf on base of oven - bread loaves, pies, roast vegetables
- Floor grid on base of oven - quiches, pies

MODERATE

- Towards top - whisked sponges, some biscuits, small cakes
- Middle - fish, soufflés, shepherd and cottage pie, lasagne
- Oven grid shelf on base of oven -
- Victoria sandwiches, shortbread, traybakes and cheesecake

LOW

For casseroles, stock, milk puddings and similar dishes bring to heat elsewhere on the AGA then transfer to the slow cook oven (one exception is meringues). Rich fruit cakes can be cooked here for a, long time on the oven grid shelf placed on the base of the oven.

Hints and Tips for using the AGA City24 (Gas Top)

Gas Top

- Wipe up spills as they happen, saves time and effort later on if the spills have baked on.
- Use good quality saucepans with a good base for best performance.
- Saucepans boil quicker with a lid on.
- A good clean is best done when the AGA City24 is cold.
- All burners have a set simmer position and are easily adjustable.
- Utensils handles should be positioned inward and not extend over adjacent surface units - to reduce the risk of burns, ignition of flammable materials and spillage due to unintentional contact with the utensil, the handle of the utensil should be positioned so that it is turned inward and does not extend over adjacent surface units.
- Hotplate burner flame size should be adjusted so that it does not extend beyond the edge of the utensil, this instruction is based on safety considerations.
- Never leave surface units unattended at high heat setting. Boil over causes smoking and greasy spillovers that may ignite.



Hints and Tips for using Ovens

Ovens

- For best results allow the ovens an hour to heat up so the castings are completely saturated in heat.
- If you are having a day of cooking, plan to cook food that needs a moderate heat first with the control turned to baking then move on to items that require a higher heat on the roasting oven setting. It takes considerably less time to get the oven to a high temperature than waiting for it to cool to a baking or moderate heat
- Needing custard? A tetra pack of ready-made custard can be heated through by placing it directly in the slow cook oven, then just open and pour into a warmed jug for serving.
- Food browning too quickly? Then slide the cold plain shelf above the dish to cut off the top heat.
- Use the large or half size roasting pan complete with the broiling rack to broil bacon, sausage, lamb chops.
- Always use the floor grid to prevent overbrowning when cooking on the base of the roasting/baking and slow cook oven.
- Cooking for a crowd? Then employ the traditional AGA technique of starting food on the gas hob then transfer to the slow cook oven, such as poaching fruit, casseroles, curries and rice, soup. It's amazing the number of saucepans you can stack in the slow cook oven.
- **DO NOT** store the plain shelf and roasting pans in the ovens as this will adversely affect heating up times and function.



Fitting of Oven Shelves

When using the oven shelves, follow as below:

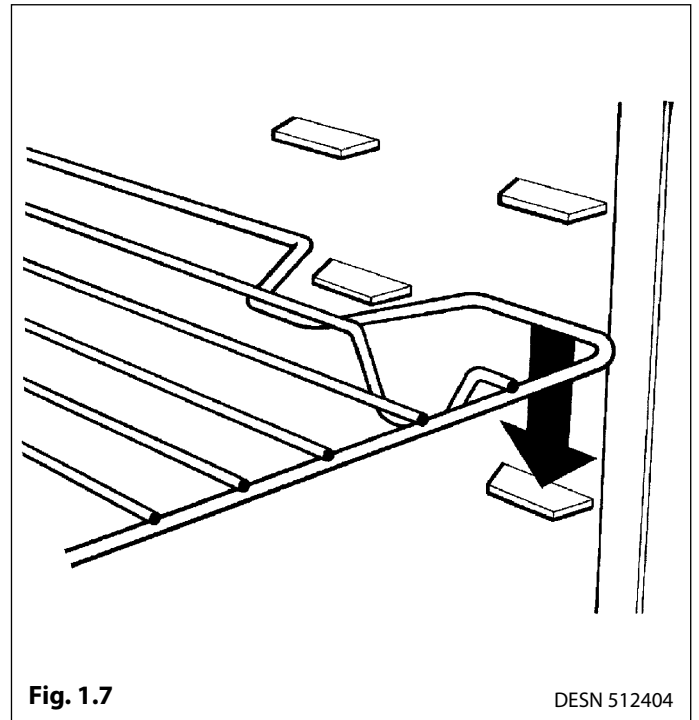
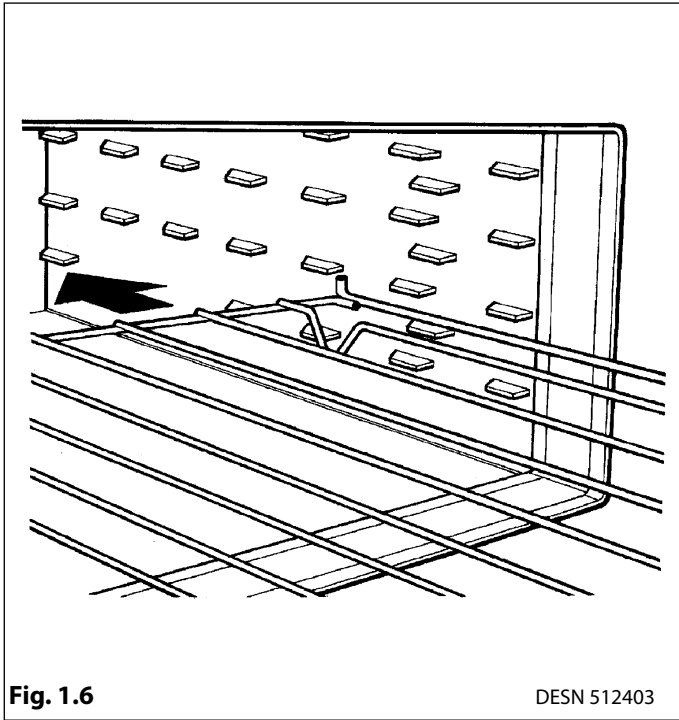

Removal of Oven Shelves

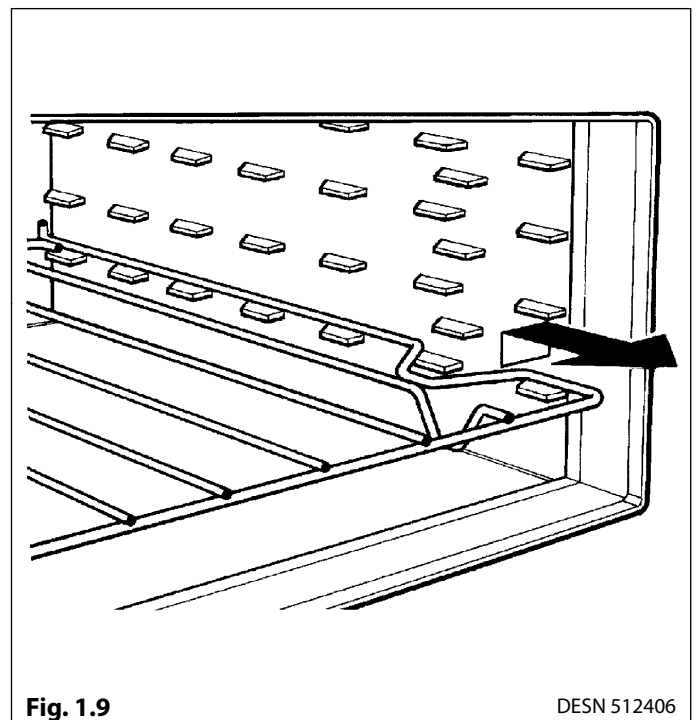
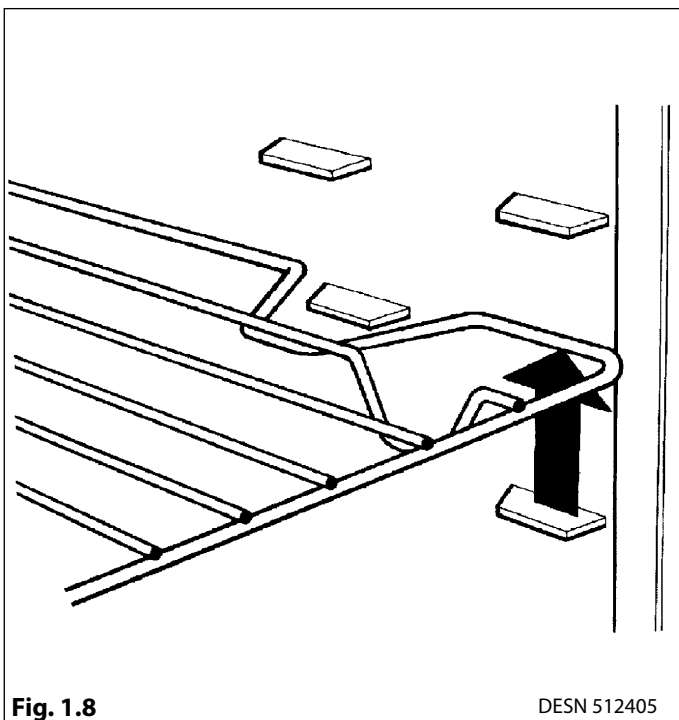

Caring and Cleaning

REMEMBER: BE CAREFUL OF THE HOT APPLIANCE.

- ⚠ ALWAYS SWITCH OFF AT MAINS BEFORE CLEANING.**
- ⚠ WHEN CLEANING USE AS LITTLE WATER AS POSSIBLE.**
- ⚠ DO NOT USE A STEAM CLEANER TO CLEAN THIS RANGE.**
- ⚠ DO NOT USE ABRASIVE PADS, CAUSTIC CLEANERS, OVEN CLEANERS OR METAL SCRAPERS TO CLEAN THE SURFACES OF THE ENAMEL.**
- ⚠ For most cleaning it is best when the appliance is turned OFF.**
- ⚠ Remember the PAN SUPPORTS will scratch if pans or utensils are dragged across them.**
- ⚠ DO NOT IMMERSE THE DOORS IN WATER AS THEY ARE PACKED WITH INSULATING MATERIAL, WHICH WILL BE DAMAGED BY EXCESSIVE MOISTURE.**
- ⚠ DO NOT PUT OVEN DOORS IN A**
- ⚠ DISHWASHER.**
- ⚠ TAKE CARE NOT TO DAMAGE THE OVEN THERMOSTAT PHIAL OR THE HOB IGNITION ELECTRODES DURING CLEANING.**
- ⚠ AFTER CLEANING. ENSURE ALL PARTS ARE THOROUGHLY DRY BEFORE REPLACING.**

Enamelled cookware

Enamelled roasting pans - supplied with the AGA City24 should be cleaned in hot soapy water, soaking if necessary. A scrub pad can also be used. They may also be cleaned in the dishwasher, but with constant use, the enamelled finish will become dull in appearance.

Enamelled cast iron

Top plate, front plate, oven doors - The easiest way to clean the enamelled cast iron parts is to mop up spills as soon as they happen. It may be useful to keep a damp cloth handy to do this. Baked on food is more difficult to clean but can usually be removed with the AGA vitreous enamel cleaner or mild cream cleaners using a damp cloth, or, if necessary a scrub pad. If milk or fruit juice or anything containing acid, is spilt on the cooker, **wipe it up immediately.**

Clean off any condensation streaks on the front plate around the oven doors or the vitreous enamel may be permanently discoloured.

To keep the vitreous enamel surfaces of the range bright and clean, a daily rub over with a damp soapy cloth followed immediately with a clean dry cloth to avoid streaks is all that is required. AGA E-cloths are excellent for this.

Cast iron ovens and Gas Top

Ovens - are made from cast iron and keep themselves clean. They are very durable, but will rust if surface moisture is left on them.

Heating up the ovens periodically will help burn off any cooking deposits to aid cleaning within the ovens.

To season the ovens, a light vegetable spray oil (corn oil is best) is recommended. Any stubborn stains can be removed with the wire brush supplied.

Gas Top - If spillage does occur on a burner cap or cast iron grate, move pan to another burner and when cool, clean in hot soapy water.

After cleaning, be sure all parts are dry. When fitting the burner cap and flame spreader, make sure that the hole in the flame spreader is correctly located over the ignition electrode (See **Fig. 1.3**, **Fig. 1.4** and **Fig. 1.5**), and that the burner cap is sitting correctly on the flame spreader.

The ignition electrode must not be displaced or damaged otherwise spark ignition will be affected.

The gas hob is sealed. To clean, remove pan supports and wipe over visible surface.

PLEASE NOTE: The following parts **MUST NOT** be cleaned in a dishwasher, as this could damage or discolour the finish, cast iron grates, burner caps, burner ring and flame spreaders.

Aluminium pans may cause metallic marking on the pan supports. This will not affect the durability of the enamel.

NOTE: The appliance guarantee does not cover the mis-use of pan supports.

Oven door linings

Oven door linings - the linings can be cleaned with hot soapy water or a non-abrasive cleaner or scrub pad. To deep clean the lining place a towel on the work surface and carefully lift off the oven door (doors are heavy) and place it enamel side down on the towel padding. Clean with soapy water and a scrub pad. to remove stubborn marks. Dry off before replacing on their hinges.

Servicing & Warranty

- In the event of your appliance requiring maintenance, please contact AGA Service or your AGA retailer.
- Your range must only be serviced by a qualified engineer, from an authorised AGA retailer.
- **DO NOT** alter or modify the range.
- Only the spares specified by the manufacturer, are to be fitted.

For continued efficient and safe operation of this appliance, it is important that servicing is carried out at regular intervals as recommended by your AGA Specialist. The range should be turned OFF in advance of the service so that the appliance will have cooled down sufficiently.

A HOT RANGE CANNOT BE SERVICED.

Service intervals to maintain the appliance warranty are as follows:

An interim service is due at two and half years (30 months) to check and change consumable items, and to undertake a safety check.

A full service is due at the end of year five (60 months).

The appliance warranty does not cover Commercial use (see separate Warranty book provided for further details).

Serial Number

Make a note of your AGA City24 Serial Number when it is being installed. The serial number can be found behind the magnetic plinth cover.

Health & Safety

Consumer Protection

As a responsible manufacturer, we take care to make sure that our products are designed and constructed to meet the required safety standards when properly installed and used.

This appliance is not intended for use by persons (including children) with reduced physical, sensory or mental capabilities, or lack of experience and knowledge, unless they have been given supervision or instruction concerning use of the appliance by a person responsible for their safety.

Children should be supervised to ensure that they do not play with the appliance.

⚠ IMPORTANT NOTICE: PLEASE READ THE ACCOMPANYING WARRANTY

⚠ Any alteration that is not approved by AGA could invalidate the approval of the appliance, operation of the warranty and could also affect your statutory rights.

Appliance

YOUNG CHILDREN SHOULD BE KEPT AWAY FROM THE APPLIANCE AS SURFACES CAN BECOME HOT TO TOUCH.

Deep Fat Frying

⚠ IMPORTANT

- Use a deep pan.
- Never fill the pan more than one-third full of fat or oil. Never use a lid on the pan. Important: Oil is a fire risk, do not leave pans containing oil unattended.
- In the event of a fire, cover the pan with a lid and turn OFF the appliance.
- Smother the flames on the hob preferably with a fire blanket, rather than attempting to remove the pan to the outside.
- Burns and injuries are caused almost invariably by picking up the burning pan to carry it outside.

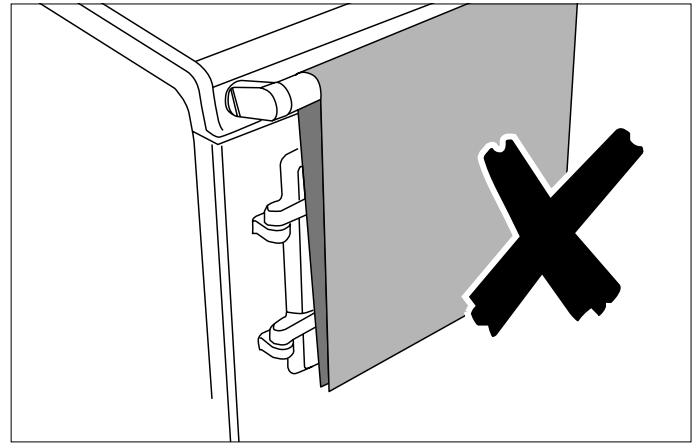

Do not hang clothes on the the AGA hand-rail.

- When the oven (s) are on **DO NOT** leave any oven door open for long periods, this will affect the temperature of the oven and may allow controls to become hot.
- A little smoke and some odour may be emitted when the appliance is first switched on. This is normal and harmless from oven lagging and starch binder on the element insulation and will cease after a short period of use.

**For further advice or information contact
your local AGA Specialist**

With AGA Marvel's policy of continuous product improvement, the Company reserves the right to change specifications and make modifications to the appliance described and illustrated at any time.



Supplied by

AGA Marvel

1260 E. Van Deirse St.

Greenville, MI 48838

Business (616) 754-5601

Fax (616) 754-9690

Toll Free Telephone 800-223-3900

www.agamarvel.com